



ANCHORING AND FASTENING SYSTEMS

For Concrete + Masonry

C-A-2016



(800) 999-5099
www.strongtie.com

The Power to Build



SIMPSON
Strong-Tie

AT-XP

Cracked Concrete
CODE LISTED

Fast-Cure High-Strength All-Weather Anchoring Adhesive
For Concrete and Masonry with Threaded Rod and Rebar

Curado rápido y alta resistencia adhesivo de sujeción para todo tipo de clima
Para concreto y mampostería con varilla rosca y barras de refuerzo

Adhésif d'ancrage toutes saisons ultra résistant à prise rapide
Pour béton et maçonnerie avec tige filetée et barres d'armature

30 fl oz
887 mL

WARNING: Combustible Liquid. May cause skin and/or eye irritation. See back panel for additional information. **KEEP OUT OF REACH OF CHILDREN.**
AVISO: Líquido combustible. Puede causar irritación de los ojos y/o de la piel. Ver panel posterior por información adicional. **MANTENER FUERA DEL ALCANCE DE LOS NIÑOS.**
ATTENTION: Liquide inflammable. Peut causer l'irritation des yeux ou de la peau. Voir les renseignements supplémentaires au verso. **GARDER HORS DE LA PORTEE DES ENFANTS.**

www.strongtie.com

SIMPSON
Strong-Tie

SET-XP

Cracked Concrete
CODE LISTED

High-Strength Anchoring Adhesive
For Concrete, Masonry with Threaded Rod and Rebar

Adhesivo para sujetadores de mucha resistencia
En concreto, mampostería con varilla rosca y barra de refuerzo

Adhésif d'ancrage à haute résistance
Pour le béton, la maçonnerie avec tige filetée et d'armature

22 fl oz
650 mL

DANGER: Corrosive. May cause skin and/or eye irritation. See back panel for additional information. **KEEP OUT OF REACH OF CHILDREN.**
PELIGRO: Corrosivo. Puede causar irritación de los ojos y/o de la piel. Ver panel posterior por información adicional. **MANTENER FUERA DEL ALCANCE DE LOS NIÑOS.**
DANGER: Corrosif. Peut causer l'irritation des yeux ou de la peau. Voir les renseignements supplémentaires au verso. **GARDER HORS DE LA PORTEE DES ENFANTS.**

www.strongtie.com

SIMPSON
Strong-Tie

ET-HP

Anchoring Adhesive
For Concrete and Masonry with Threaded Rod and Rebar

Adhesivo de fijación
Para concreto y mampostería con varilla rosca y una barra de refuerzo

Adhésif d'ancrage
Pour béton et maçonnerie avec tige et barre d'armature

22
650

DANGER: Corrosive. May cause skin and/or eye irritation. See back panel for additional information. **KEEP OUT OF REACH OF CHILDREN.**
PELIGRO: Corrosivo. Puede causar irritación de los ojos y/o de la piel. Ver panel posterior por información adicional. **MANTENER FUERA DEL ALCANCE DE LOS NIÑOS.**
DANGER: Corrosif. Peut causer l'irritation des yeux ou de la peau. Voir les renseignements supplémentaires au verso. **GARDER HORS DE LA PORTEE DES ENFANTS.**

www.strongtie.com

For nearly 60 years, Simpson Strong-Tie has focused on providing powerful solutions to meet our customers' needs.

We offer a full array of anchoring systems for residential, commercial, infrastructure and industrial uses – from anchoring adhesives and mechanical anchors for anchoring applications in concrete and masonry to direct fastening solutions for attachments to concrete, steel, CMU, or metal deck.

The innovative products featured in this catalog are the result of more than 40 years of research and development, and have passed the rigorous quality-assurance testing you have come to expect from Simpson Strong-Tie. With our expanding lines of high-performance anchoring products, engineering and field support, product testing and training, we are committed to giving you the power to build.

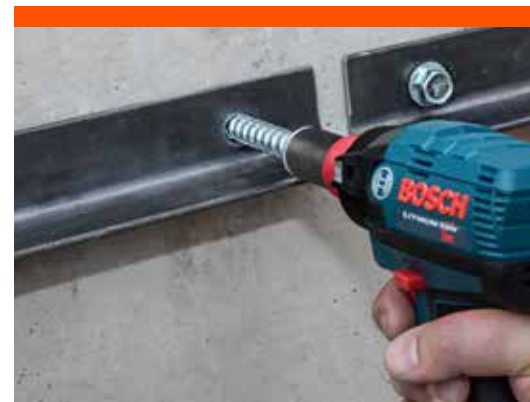

Anchor Product Selection Guide

Product			Page No.	Tested Base Materials and Code Listings						Other Listings	
				Concrete		Concrete on Metal Deck	CMU		Unreinforced Clay Brick Masonry		Other
				Cracked	Uncracked		Grout-Filled	Hollow			
Adhesive Anchors	AT-XP®		20	ER-263, RR25960, FL-16230.1		—	ER-281, RR25966, FL-16230.1	—	—	—	NSF/ANSI Std 61, DOT
	SET-XP®		38	ESR-2508, RR25744, FL-17449.2		—	ER-265, RR25965, FL-16230.3	ER-265	—	—	NSF/ANSI Std 61, DOT
	ET-HP®		62	ESR-3372, FL-17449.1		—	ER-241 FL-16230.2	—	ESR-3638, RR25120	—	DOT
	AT		86	—	Non-IBC	—	Non-IBC	Non-IBC	ESR-1958	—	DOT
	SET		102	—	Non-IBC	—	Non-IBC	Non-IBC	ESR-1772, FL-15730.5	—	NSF/ANSI Std 61, DOT
	EDOT		122	—	Non-IBC	—	—	—	—	—	DOT
Mechanical Anchors	Torq-Cut™		138	ESR-2705, RR25946, FL-15731.3		—	—	—	—	—	—
	Strong-Bolt® 2		144	ESR-3037, RR25891, FL-15731.2		ESR-3037 RR25891 FL-15731.2	ER-240, RR25936 FL-16230.4	—	—	—	UL, FM, DOT
	Wedge-All®		164	—	Non-IBC	Non-IBC	ESR-1396, FL-15730.7	—	—	—	UL, FM, DOT
	Easy-Set		179	—	Non-IBC	—	—	—	—	—	—
	Sleeve-All®		180	—	Non-IBC	—	Non-IBC	—	—	—	UL, FM, DOT
	Titen HD®		184	ESR-2713, RR25741, FL-15730.6			ESR-1056, RR25560, FL-15730.6	IBC	—	—	FM, DOT
	Titen®		203	—	FL-2355.1	—	FL-2355.1		—	—	—
	Titen HD® Rod Hanger		208	ESR-2713, RR25741, FL-15730.6		ESR-2713 RR25741	—	—	—	—	FM
	 Wood Rod Hanger		212	—	—	—	—	—	—	IBC (Wood)	UL, FM

Anchor Product Selection Guide

Product			Page No.	Tested Base Materials and Code Listings						Other Listings	
				Concrete		Concrete on Metal Deck	CMU		Unreinforced Clay Brick Masonry		Other
				Cracked	Uncracked		Grout-Filled	Hollow			
Mechanical Anchors	Blue Banger Hanger®		214	ESR-3707		ESR-3707	—	—	—	IBC (Steel Roof Deck)	UL, FM
	 Drop-In (DIAB)		224	—	Non-IBC	Non-IBC	—	—	—	—	UL, FM
	Drop-In (DIA)		229	—	Non-IBC	Non-IBC	—	—	—	Non-IBC (Hollow Core Panel)	UL, FM, DOT
	 Hollow Drop-In		236	—	Non-IBC	—	—	IBC	—	—	UL, FM
	Zinc Nailon™		241	—	Non-IBC	—	—	—	—	—	—
	Lag Screw Expansion Shield		239	—	Non-IBC	—	—	—	—	—	—
	Expansion Screw Anchor		240	—	Non-IBC	—	—	—	—	—	—
	 Crimp Drive®		242	—	Non-IBC	Non-IBC	—	—	—	—	FM
	Split Drive		244	—	Non-IBC	—	—	—	—	—	—
	Tie-Wire		177	—	Non-IBC	Non-IBC	—	—	—	—	—
	Sure Wall		245	—	—	—	—	—	—	Drywall	—
Direct Fastening	Powder-Actuated Fasteners		266	—	ESR-2138, RR25469, FL-15730.3, FL-15730.4	ESR-2138, RR25469, FL-15730.3, FL-15730.4	ESR-2138, RR25469, FL-15730.3, FL-15730.4	ESR-2138, RR25469, FL-15730.3, FL-15730.4	—	Steel ESR-2138, RR25469, FL-15730.3, FL-15730.4	FM
	Gas-Actuated Fasteners		249	—	ESR-2811, RR25837, FL-15730.1, FL-15730.2	ESR-2811, RR25837, FL-15730.1, FL-15730.2	ESR-2811, RR25837, FL-15730.1, FL-15730.2	ESR-2811, RR25837, FL-15730.1, FL-15730.2	—	Steel, ESR-2811, FL-15730.1, FL-15730.2	—



ESR or ER – ICC-ES or IAPMO UES code report available.
 RR – City of Los Angeles research report available.
 FL – Florida building code approval available.
 IBC – Load data is available in this catalog intended for use under IBC, but code listings are not available.

Non-IBC – Load data is available in this catalog, but it is outside the scope of the current IBC. May be permitted for non-IBC applications.
 UL – Underwriters Laboratories listing available.
 FM – Factory Mutual listing available.
 DOT – Various departments of transportation listings available.
 See www.strongtie.com/DOT for details.





Consult the code listings for more detailed information on which models of each product are covered by the listing.

Table of Contents

Adhesive Anchors

Adhesive Accessories	128
Adhesive Anchoring Installation Instructions.....	124
Adhesive Retaining Caps	132
Adhesive Shear Tubes.....	135
AT Acrylic Adhesive.....	86
 AT-XP® Acrylic Adhesive.....	20
EDOT Adhesive.....	122
ET-HP® Adhesive.....	62
Hole-Cleaning Brushes	135
Steel Adhesive Anchoring Screen Tubes.....	133
Opti-Mesh Adhesive Anchoring Screen Tubes	134
 Piston Plug Delivery System.....	130
Retrofit Bolt	135
SET Epoxy Adhesive.....	102
SET-XP® Epoxy Adhesive.....	38

Mechanical Anchors

Blue Banger Hanger® Threaded Insert	214
 Crimp Drive® Anchor	242
 Drop-In Internally Threaded Anchor (DIAB).....	224
Drop-In Internally Threaded Anchor (DIA)	229
Easy-Set Pin-Drive Anchor.....	179
Expansion Screw Anchor.....	240
 Hollow Drop-In Anchor.....	236
LSES Lag Screw Expansion Shield	239
Sleeve-All® Sleeve Anchor	180
Split-Drive Anchor	244
Strong-Bolt® 2 Wedge Anchor	144
Sure Wall Drywall Anchor	245
 Tie-Wire Anchor	177
Titen HD® Screw Anchor.....	184
Titen® Screw	203
Titen® Stainless-Steel Screw	205
Titen HD® Rod Hanger.....	208
Titen HD® Rod Coupler	201
Torq-Cut™ Self-Undercutting Anchor.....	138
Wedge-All® Wedge Anchor	164
 Wood Rod Hanger.....	212
Zinc Nailon™ Pin Drive Anchor.....	241

Direct Fastening

Extension Tools	252
Fastener Load Tables.....	273
Gas-Actuated Fasteners and Accessories	249
GCN-MEP Concrete Nailer	248
Powder-Actuated Fasteners.....	266
Powder-Actuated Tool/Load/Fastener Matrix	253
Powder-Actuated Tool Matrix	254
Powder Loads.....	265
PTP-27L / PTP-27LMAGR.....	256
PTP-27S / PTP-27SMAGR	258
 PT-27HDA.....	260
PT-27	261
PT-22A.....	262
PT-22HA	263
PT-22P	264

Restoration Solutions

Crack Injection Guide.....	293
Crack-Pac® Flex-H ₂ O™	288
Crack-Pac® Injection Epoxy	286
Crack Repair Accessories	289
Epoxy Injection Guide	296
ETI Injection Epoxy.....	284
 Heli-Tie™ Helical Stitching Tie	292
Heli-Tie™ Helical Wall Tie	290

Carbide Drill Bits and Accessories

“A” Taper Drill Bits	306
Core Bits.....	313
Demolition Bits	310
Rebar Cutter	308
Rebar Cutter Adaptors.....	309
SDS-MAX® Drill Bits	304
SDS-PLUS® Drill Bits.....	302
Spline/Straight Shank Drill Bits	305

Additional Information

Allowable Stress Design Method.....	322
Alphabetical Index of Products.....	335
Anchor Selection Guide	4
Corrosion Information.....	316
Example Design Calculations	324
General Instructions for the Designer	15
General Instructions for the Installer	13
Glossary of Common Terms.....	332-334
Strength Design Method	322
Suggested General Notes for Anchor Products	331
Supplemental Topics for Anchors.....	316-318
Table Icons	12



New products are shown with the  symbol.

Simpson Strong-Tie Company Inc.

For nearly 60 years, Simpson Strong-Tie has focused on creating structural products that help people build safer and stronger homes and buildings. A leader in structural systems research and technology, Simpson Strong-Tie is one of the largest suppliers of structural building products in the world. The Simpson Strong-Tie commitment to product development, engineering, testing and training is evident in the consistent quality and delivery of its products and services.

For more information, visit the company's website at www.strongtie.com.

The Simpson Strong-Tie Company Inc. "No Equal" pledge includes:

- Quality products value-engineered for the lowest installed cost at the highest-rated performance levels
- Most thoroughly tested and evaluated products in the industry
- Strategically located manufacturing and warehouse facilities
- National code agency listings
- Largest number of patented connectors in the industry
- Global locations with an international sales team
- In-house R&D and tool and die professionals
- In-house product testing and quality control engineers
- Support of industry groups including AISI, AITC, ASTM, ASCE, AWC, AWPA, ACI, AISC, CSI, CFSEI, ICFA, NBMDA, NLBMDA, SDI, SETMA, SFA, SFIA, STAFDA, SREA, NFBA, TPI, WDSC, WIJMA, WTCA and local engineering groups.

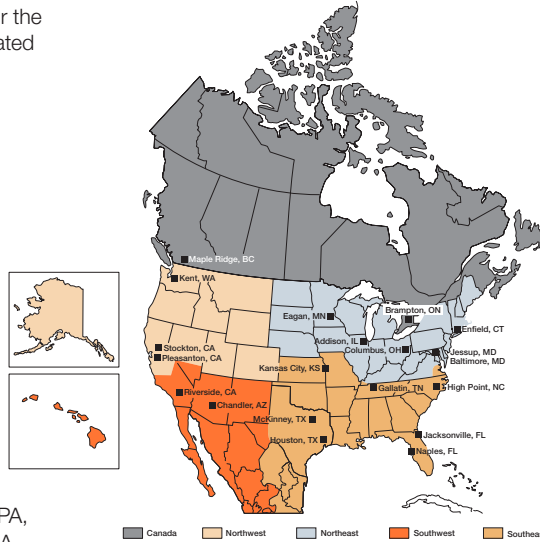

Product Identification Key

Products and additional information are divided into eight general categories, identified by tabs along the page's outer edge.

Adhesive Anchors 18—135 ▶

Mechanical Anchors 136—245 ▶

Direct Fastening 246—281 ▶

Restoration Solutions 282—297 ▶

Carbide Drill Bits 298—313 ▶

Appendix 314—331 ▶

Glossary of Terms 332—334 ▶

Alphabetical Index of Products 335—340 ▶

The Simpson Strong-Tie Quality Policy

We help people build safer structures economically. We do this by designing, engineering and manufacturing "No Equal" structural connectors and other related products that meet or exceed our customers' needs and expectations. Everyone is responsible for product quality and is committed to ensuring the effectiveness of the Quality Management System.

Karen Colonias
Chief Executive Officer

Getting Fast Technical Support

When you call for engineering technical support, we can help you quickly if you have the following information at hand. This will help us to serve you promptly and efficiently.

- Which Simpson Strong-Tie catalog are you using? (See the front cover for the form number.)
- Which Simpson Strong-Tie product are you using?
- What are the design requirements (i.e., loads, anchor diameter, base material, edge/spacing distance, etc.)?

We Are ISO 9001-2008 Registered

Simpson Strong-Tie is an ISO 9001-2008 registered company. ISO 9001-2008 is an internationally recognized quality assurance system that lets our domestic and international customers know they can count on the consistent quality of Simpson Strong-Tie® products and services.



800-999-5099 | www.strongtie.com

New Products



AT-XP® High-Strength Acrylic Adhesive

Formulated for high-strength anchorage of threaded rod and rebar into concrete (cracked or uncracked) and masonry under a wide range of conditions, AT-XP dispenses easily in cold or warm environments and, when mixed, is a dark teal color for easy identification.

See page 20 for more information.



Adhesive Piston Plug Delivery System

The Simpson Strong-Tie® Adhesive Piston Plug Delivery System facilitates consistent dispensing of anchoring adhesives in any installation orientation. The matched tolerance design between the piston plug and the drilled hole virtually eliminates the formation of voids and air pockets during adhesive dispensing.

See page 130 for more information.



Battery-Powered Dispensing Tool for Acrylic Adhesives

The ADTA30CKT offers power dispensing of 30 oz., 10:1-ratio, dual-cartridge adhesives without the need for a hose or compressor. Tool comes complete with two 18V lithium-ion battery packs and a charger.

See page 128 for more information.



Battery-Powered Dispensing Tool for Epoxy Adhesives

The EDTA22CKT offers power dispensing of 22 oz., 1:1-ratio, dual-cartridge adhesives without the need for a hose or compressor, and may be easily converted to dispense 16.5 oz., 2:1-ratio, dual-cartridge adhesives (conversion parts included). Tool comes complete with two 18V lithium-ion battery packs and a charger.

See page 128 for more information.

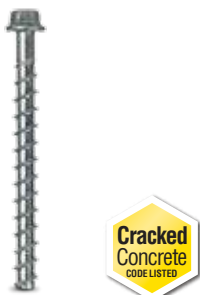

Titen HD® 1/4" Screw Anchor

The new 1/4" Titen HD Screw Anchor (THDB25) offers the same self-undercutting, non-expansion characteristics as the popular Titen HD anchor and is code listed for use in cracked and uncracked concrete.

See page 184 for more information.

New Products

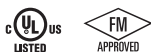

Hollow Drop-In Anchor

The Simpson Strong-Tie® Hollow Drop-In Anchor (HDIA) is an internally threaded, flush-mount expansion anchor for use in hollow materials such as CMU and hollow-core plank, as well as in solid base materials.

See page 236 for more information.

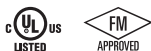

Drop-In Internally Threaded Anchor (DIAB)

The redesigned drop-in internally threaded expansion shell anchors set easily by driving the expansion plug towards the bottom of the anchors using the specially designed SDS or hand-drive setting tool. A positive-set indicator shows when the plug is fully set and the anchor has properly expanded.

See page 224 for more information.



Heli-Tie™ Helical Stitching Tie

The Simpson Strong-Tie® helical stitching tie provides a unique solution for the preservation and repair of damaged brick and masonry structures. The stitching tie is grouted across the crack to reconnect and distribute the loads over a large surface area while providing an inconspicuous repair that preserves and maintains the appearance of the structure.

See page 292 for more information.



Wood Rod Hanger

The new wood rod hanger is a one-piece fastening system for suspending 1/4" or 3/8" threaded rod from wood members. Both vertical and horizontal rod hangers provide attachment points for use in pipe hanging, fire protection and cable-tray applications. The Type-17 point provides for fast starts with no pre-drilling required.

See page 212 for more information.

New Products



PT-27HDA

The PT-27HDA is a low-velocity, heavy-duty powder-actuated tool designed for installing fasteners into poured and precast concrete, grout-filled concrete masonry block, horizontal mortared joints and structural steel.

See page 260 for more information.



Tie-Wire Anchor

A wedge-style expansion anchor for use in normal-weight concrete or concrete over metal deck. Offers a tri-segmented, dual-embossed clip.

See page 177 for more information.



Crimp Drive® Countersunk

The Crimp Drive countersunk anchor is an easy-to-install expansion anchor for use in concrete and grout-filled CMU. The product design helps speed up anchor installation and reduce overall cost.

See page 242 for more information.



SDS Stop Bit

The fixed-depth drill bit – designed to meet the hole-depth specifications of most drop-in style anchors, including the DIA and DIAB series anchors – takes the guesswork out of drilling to correct depth, saving time and bit life.

See pages 225 or 303 for more information.

How to Use This Catalog

Using Data Tables and Load Tables

This catalog contains both strength design data tables and allowable load tables. Some allowable load tables for concrete were established under old qualification standards that are no longer valid under the IBC. The following icons indicate whether or not a given table is intended to be used under the IBC (or under other building codes that use the IBC as their basis):



Tables that are “not valid for International Building Code” may be used where the designer determines that other building codes or regulations permit it — for example, under AASTHO or temporary construction.

Strength Design Data Tables

Under the IBC, strength design (see page 322) must be used for cast-in-place and post-installed mechanical and adhesive anchors that are installed into concrete. The design data from these tables are to be used with the design provisions of ACI 318 Appendix D, IBC Chapter 19 and the respective ICC-ES Acceptance Criteria. Strength design data tables are watermarked with the letters “SD.” Given the complexity of strength design calculations, designers may find Simpson Strong-Tie® Anchor Designer™ software (www.strongtie.com/software) to be a great time saver for computing anchor design strengths using the tabulated design data.

Characteristic	Symbol	Units	Nominal Anchor Diameter (in.)								
			½	¾	1	1¼	1½	2	2½	3	
Steel Strength in Tension											
Minimum Tensile Stress Area	A_s	in ²	0.078	0.142	0.226	0.334	0.462	0.606	0.969		
Tension Resistance of Steel — ASTM F1554, Grade 36			4,525	8,235	13,110	19,370	26,705	35,150	55,200		
Tension Resistance of Steel — ASTM A193, Grade B7			9,750	17,750	28,250	41,750	57,750	75,750	121,125		
Tension Resistance of Steel — Type 410 Stainless (ASTM A193, Grade B8)	N_{st}	lb	8,580	15,620	24,860	36,740	50,820	68,050	106,590		
Tension Resistance of Steel — Type 304 and 316 Stainless (ASTM A193, Grade B8 & B8M)			4,445	8,095	12,880	19,040	26,335	34,540	55,235		
Strength Reduction Factor — Steel Failure	ϕ	—						0.75 ²			
Concrete Breakout Strength in Tension (2,500 psi ≤ f_c ≤ 8,000 psi)²											
Effectiveness Factor — Uncracked Concrete	k_{ucr}	—					24				
Effectiveness Factor — Cracked Concrete	k_{cr}	—					17				
Strength Reduction Factor — Breakout Failure	ϕ	—					0.65 ³				
Bond Strength in Tension (2,500 psi ≤ f_c ≤ 8,000 psi)²											
Uncracked Concrete ^{1,4}	Characteristic Bond Strength ^{1,11}	τ_{uc}	psi	770	1,150	1,000	970	885	790	620	
	Permitted Embedment Depth Range	Minimum	in	2 ¾	2 ¾	3 ¾	3 ¾	3 ¾	4	5	
Cracked Concrete ^{1,4}	Characteristic Bond Strength ^{1,11, 14}	τ_{cr}	psi	715	10	12 ½	15	17 ½	20	25	
	Permitted Embedment Depth Range	Minimum	in	3	4	5	6	7	8	10	

Example Strength Design Data Table

Allowable Load Tables

Under the IBC, allowable stress design (see page 322) maybe used for cast-in-place and post-installed adhesive and mechanical anchors installed into masonry or for gas/powder-actuated fasteners installed into concrete, masonry or steel.

Diameter (in.) or Rebar Size No.	Drill Bit Diameter (in.)	Minimum Embedment ¹ (in.)	Allowable Load Based on Bond Strength ¹ (lb.)		
			Tension Load	Shear Perp.	Shear Parallel
Threaded Rod Installed in the Top of CMU Wall					
½	¾	4 ½	1,485	500	1,050
		12	2,440	665	1,625
¾	¾	5 ½	1,700	565	1,435
		15	2,660	680	1,785
1	¾	6 ½	1,610	735	1,370
		21	4,760	670	1,375
Rebar Installed in the Top of CMU Wall					
#4	¾	4 ½	1,265	550	865
		12	2,715	465	1,290
#5	¾	5 ½	1,245	590	1,140
		15	3,090	590	1,285

1. Allowable load shall be the lesser of the bond values shown in this table and steel values, shown on page XX.
 2. Allowable loads are for installation in the grouted CMU core opening.
 3. Embedment depth shall be measured from the horizontal surface of the grouted CMU core opening on top of the masonry wall.

Example Allowable Load Table

Important Information and General Notes

Under the IBC, allowable stress design may only be used for cast-in-place and post-installed mechanical and adhesive anchors installed into concrete if the allowable loads are converted from strength design calculations. Converted allowable loads are very specific to the design assumptions described in the tables.

SET-XP® Allowable Tension Loads for Threaded Rod Anchors in Normal-Weight Concrete ($f'_c = 2,500$ psi) – Static Load

Rod Dia. (in.)	Nominal Embed. Depth (in.)	Minimum Dimensions for Uncracked (in.)		Minimum Dimensions for Cracked (in.)		Allowable Tension Load Based on Concrete or Bond (lb.)				
		h_{ef}	c_{ac}	h_{ef}	c_{ac}	Edge distances = c_{ac} on all sides		Edge Distances = $1\frac{1}{2}c_{ac}$ on one side and c_{ac} on three sides		
						Uncracked	Cracked	Uncracked	Cracked	
¾"	2½"	4¼"	3¾"	—	—	845	—	480	—	
	3"	5½"	3¾"	—	—	—	—	570	—	
		4¼"	5"	4¼"	3¾"	1,070	820	455	555	
	4½"	7½"	4½"	—	—	—	—	630	—	
		6"	6"	8¾"	6"	3¾"	1,605	1,230	420	830
	5"	10"	7½"	8¾"	—	—	—	—	630	—
6"		10¾"	11¾"	7½"	4"	2,140	1,645	465	1,110	
7½"		14½"	9"	—	—	—	—	630	1,110	
¾"	9"	9"	14½"	9"	5"	2,675	2,055	400	1,390	
	18"	11½"	—	—	—	—	—	630	1,390	
	4"	5¼"	5"	—	—	—	1,950	—	1,050	—
		6"	5"	—	—	—	—	—	1,050	—
	5"	6½"	7¾"	6½"	5"	2,840	1,255	1,000	675	
		9"	6"	—	—	—	—	—	1,390	—
¾"	6"	8¾"	12¾"	8½"	5"	4,255	1,880	950	1,015	
	8"	14½"	9"	—	—	—	—	1,390	—	
	10"	10½"	17½"	10½"	5"	5,680	2,505	900	1,350	
		19½"	12"	—	—	—	—	—	1,390	—
¾"	3"	6½"	6"	—	—	2,555	—	680	1,680	
	5"	7½"	6½"	—	—	—	—	1,390	—	
		8"	6½"	8"	6"	4,095	1,670	1,290	840	
	7½"	12"	7½"	—	—	—	—	1,340	—	
		10"	10"	15¾"	10"	6"	6,140	2,500	1,850	1,245
	12½"	18"	11½"	—	—	—	—	—	1,850	1,260
15¾"		26¾"	15¾"	7"	10,230	4,165	1,180	2,105		
¾"	3"	7¼"	7½"	—	—	3,130	—	1,850	—	
	6"	8½"	7"	—	—	—	—	1,515	—	
		9"	11"	9"	7½"	5,370	2,145	1,670	1,035	
¾"	14½"	9"	—	—	—	—	—	2,305	—	
	9"	12¾"	17¾"	12"	7"	8,055	3,215	1,955	1,555	
	21¾"	13¾"	—	—	—	—	—	2,305	—	

Example Converted Allowable Load Table

Table Icon System

In order to facilitate easier identification of performance data, the following icon system has been incorporated into the sections of the catalog with multiple load tables. These icons will appear in the heading of the table to promote easier visual identification of the type of load, insert type and substrate addressed in the table. Icons are intended for quick identification. All specific information regarding suitability should be read from the table itself.

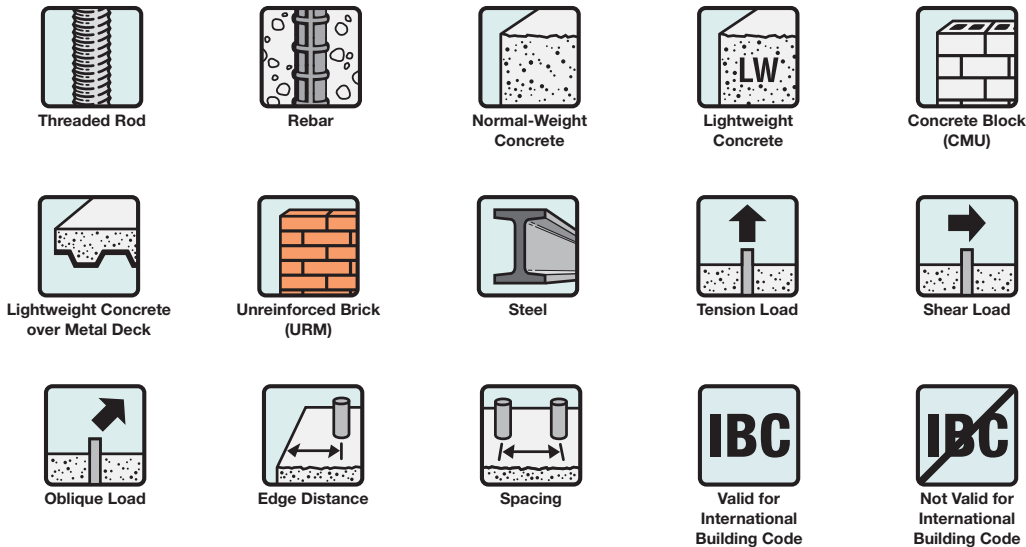

Important Information and General Notes

General Notes

These general notes are provided to ensure proper installation of Simpson Strong-Tie Company Inc. products and must be followed fully.

- Simpson Strong-Tie Company Inc. reserves the right to change specifications, designs, and models without notice or liability for such changes.
- Unless otherwise noted, dimensions are in inches and loads are in pounds.
- Do not overload, which will jeopardize the anchorage. Service loads shall not exceed published allowable loads. Factored loads shall not exceed design strengths calculated in accordance with published design data.
- Some hardened fasteners may experience premature failure if exposed to moisture. These fasteners are recommended to be used in dry interior applications.
- Do not weld products listed in this catalog. Some steel types have poor weldability and a tendency to crack when welded.

General Instructions for the Installer

These general instructions for the installer are provided to ensure the proper selection and installation of Simpson Strong-Tie products and must be followed carefully. They are in addition to the specific design and installation instructions and notes provided for each particular product, all of which should be consulted prior to and during the installation of Simpson Strong-Tie products.

- Do not modify Simpson Strong-Tie products as the performance of modified products may be substantially weakened. Simpson Strong-Tie will not warrant or guarantee the performance of such modified products.
- Do not alter installation procedures from those set forth in this catalog.
- Drill holes for post-installed anchors with carbide-tipped drills meeting the diameter requirements of ANSI B212.15 (shown in the table to the right). A properly sized hole is critical to the performance of post-installed anchors. Rotary-hammered drills with light, high-frequency impact are recommended for drilling holes. When holes are to be drilled in archaic or hollow base materials, the drill should be set to "rotation only" mode.
- For mechanical anchors requiring specific installation torque: Failure to apply the recommended installation torque can result in excessive displacement of the anchor under load or premature failure of the anchor. These anchors will lose pre-tension after setting due to pre-load relaxation. See page 316 for more information.
- Do not disturb, bolt up, or apply load to adhesive anchors prior to the full cure of the adhesive.
- Use proper safety equipment.

Finished Diameters for Rotary and Rotary-Hammer Carbide-Tipped Concrete Drills per ANSI B212.15

Nominal Drill Bit Diameter (in.)	Tolerance Range Minimum (in.)	Tolerance Range Maximum (in.)
1/8	0.134	0.140
9/32	0.165	0.171
3/16	0.198	0.206
7/32	0.229	0.237
1/4	0.260	0.268
5/16	0.327	0.335
3/8	0.390	0.398
7/16	0.458	0.468
1/2	0.520	0.530
9/16	0.582	0.592
5/8	0.650	0.660
11/16	0.713	0.723
3/4	0.775	0.787
13/16	0.837	0.849
27/32	0.869	0.881
7/8	0.905	0.917
15/16	0.968	0.980
1	1.030	1.042
1 1/8	1.160	1.175
1 1/16	1.223	1.238
1 1/4	1.285	1.300
1 5/16	1.352	1.367
1 3/8	1.410	1.425
1 7/16	1.472	1.487
1 1/2	1.535	1.550
1 9/16	1.588	1.608
1 5/8	1.655	1.675
1 3/4	1.772	1.792
2	2.008	2.028

Important Information and General Notes

Additional Instructions for the Installer for Gas- and Powder-Actuated Fastening

Before operating any Simpson Strong-Tie gas- or powder-actuated tool, you must read and understand the Operator's Manual and be trained by an authorized instructor in the operation of the tool. Simpson Strong-Tie recommends you read and fully understand the safety guidelines of the tool you use. To become a Certified Operator of Simpson Strong-Tie gas- and powder-actuated tools, you must pass a test and receive a certified operator card. Test and Operator's Manual are included with each tool kit. Extra copies may be obtained by contacting Simpson Strong-Tie at (800) 999-5099.

To avoid serious injury or death:

- a. Always make sure that the operators and bystanders wear safety glasses. Hearing and head protection is also recommended.
- b. Always post warning signs within the area when gas- or powder-actuated tools are in use. Signs should state "Tool in Use."
- c. Always store gas- and powder-actuated tools unloaded. Store tools and powder loads in a locked container out of reach of children.
- d. Never place any part of your body over the front muzzle of the tool, even if no fastener is present. The fastener, pin or tool piston can cause serious injury or death in the event of accidental discharge.
- e. Never attempt to bypass or circumvent any of the safety features on a gas- or powder-actuated tool.
- f. Always keep the tool pointed in a safe direction.
- g. Always keep your finger off the trigger.
- h. Always keep the tool unloaded until ready to use.
- i. Always hold the tool perpendicular (90°) to the fastening surface to prevent ricocheting fasteners. Use the spall guard whenever possible.
- j. Never attempt to fasten into soft, thin, brittle or very hard materials such as drywall, light-gauge steel, glass, tile or cast iron as these materials are inappropriate. Conduct a pre-punch test to determine base material adequacy.
- k. Never attempt to fasten into soft material such as drywall or wood. Fastening through soft materials into appropriate base material may be allowed if the application is appropriate.
- l. Never attempt to fasten to a spalled, cracked or uneven surface.

Important Information and General Notes

General Instructions for the Designer

These general instructions for the designer are provided to ensure the proper selection and installation of Simpson Strong-Tie® products and must be followed carefully. They are in addition to the specific design and installation instructions and notes provided for each particular product, all of which should be consulted prior to and during the design process.

- a. The term “Designer” used throughout this catalog is intended to mean a licensed/certified building design professional, a licensed professional engineer or a licensed architect.
 - b. All connected members and related elements shall be designed by the Designer and must have sufficient strength (bending, shear, etc.) to resist the loads imposed by the anchors.
 - c. When the allowable stress design method is used, the design service load shall not exceed the published allowable loads reduced by load-adjustment factors for temperature, spacing and edge distance. Where stated in this catalog, allowable loads may be increased 33⅓% when permitted by code. In general, this is permissible only when the alternative basic load combinations of the IBC are used.
 - d. When the strength design method is used, the factored loads shall not exceed the design strengths calculated in accordance with the published design data.
 - e. Simpson Strong-Tie strongly recommends the following addition to construction drawings and specifications: “Simpson Strong-Tie products are specifically required to meet the structural calculations of plan. Before substituting another brand, confirm load capacity based on reliable published testing data or calculations. The Engineer/Designer should evaluate and give written approval for substitution prior to installation.”
 - f. Where used in this catalog, “IBC” refers to the 2012 International Building Code, and “ACI 318” refers to ACI 318-11 Building Code Requirements for Structural Concrete. Local and/or regional building codes may require meeting special conditions. Building codes often require special inspection of anchors. For compliance with these requirements, contact the local building authority. Except where mandated by code, Simpson Strong-Tie products do not require special inspection.
 - g. Allowable loads and design strengths are determined from test results, calculations and experience. These are guide values for sound base materials with known properties. Due to variation in base materials and site conditions, site-specific testing should be conducted if exact performance in a specific base material at a specific site must be known.
 - h. Unless stated otherwise, tests conducted to derive performance information were performed in members with minimum thickness equal to 1.5 times the anchor embedment depth. Anchoring into thinner members requires the evaluation and judgment of a qualified Designer.
 - i. Tests are conducted with anchors installed perpendicular ($\pm 6^\circ$ from a vertical reference) from a vertical reference to the surface of the base material. Deviations can result in anchor bending stresses and reduce the load-carrying capacity of the anchor.
 - j. Allowable loads and design strengths do not consider bending stresses due to shear loads applied with large eccentricities.
 - k. Metal anchors and fasteners will corrode and may lose load-carrying capacity when installed in corrosive environments or exposed to corrosive materials. See page 316.
 - l. Mechanical anchors should not be installed into concrete that is less than 7 days old. The allowable loads and design strengths of mechanical anchors that are installed into concrete less than 28 days old should be based on the actual compressive strength of the concrete at the time of installation.
 - m. Nominal embedment depth (“embedment depth”) is the distance from the surface of the base material to the installed end of the anchor and is measured prior to application of an installation torque (if applicable). Effective embedment depth is the distance from the surface of the base material to the deepest point at which the load is transferred to the base material.
 - n. Drill bits shall meet the diameter requirements of ANSI B212.15. For adhesive anchor installations in oversized holes, see page 318. For adhesive anchor installations into core-drilled holes, see page 319.
 - o. Threaded-rod inserts for adhesive anchors shall be oil-free UNC fully threaded steel. Bare steel, zinc plating, mechanical galvanizing or hot-dip galvanizing coatings are acceptable.
 - p. Allowable loads and design strengths are generally based on testing of adhesive anchors installed into dry holes. For installations into damp, wet and submerged environments, see page 319.
- ACI 318 states that adhesive anchors should not be installed into concrete that is less than 21 days old. For information on adhesive anchors installed into concrete less than 21 days old, see page 318.
- q. Adhesive anchors can be affected by elevated base material temperature. See page 319.
 - r. Anchors are permitted to support fire-resistant construction provided at least one of the following conditions is fulfilled: (a) anchors are used to resist wind or seismic forces only; (b) anchors that support gravity-load-bearing structural elements are within a fire-resistive envelope or a fire-resistive membrane, are protected by approved fire-resistive materials, or have been evaluated for resistance to fire exposure in accordance with recognized standards; or (c) anchors are used to support non-structural elements.
 - s. Exposure to some chemicals may degrade the bond strength of adhesive anchors. Refer to the product description for chemical resistance information or refer to see page 320.

Important Information and General Notes

Limited Warranty

Simpson Strong-Tie Company Inc. warrants catalog products to be free from defects in material or manufacturing. Simpson Strong-Tie Company Inc. products are further warranted for adequacy of design when used in accordance with design limits in this catalog and when properly specified, installed and maintained. This warranty does not apply to uses not in compliance with specific applications and installations set forth in this catalog, or to non-catalog or modified products, or to deterioration due to environmental conditions.

Simpson Strong-Tie® anchors, fasteners and connectors are designed to enable structures to resist the movement, stress and loading that results from impact events such as earthquakes and high-velocity winds. Other Simpson Strong-Tie products are designed to the load capacities and uses listed in this catalog. Properly installed Simpson Strong-Tie products will perform in accordance with the specifications set forth in the applicable Simpson Strong-Tie catalog. Additional performance limitations for specific products may be listed on the applicable catalog pages.

Due to the particular characteristics of potential impact events, the specific design and location of the structure, the building

materials used, the quality of construction, and the condition of the soils involved, damage may nonetheless result to a structure and its contents even if the loads resulting from the impact event do not exceed Simpson Strong-Tie catalog specifications and Simpson Strong-Tie connectors are properly installed in accordance with applicable building codes.

All warranty obligations of Simpson Strong-Tie Company Inc. shall be limited, at the discretion of Simpson Strong-Tie Company Inc., to repair or replacement of the defective part. These remedies shall constitute the sole obligation of Simpson Strong-Tie Company Inc. and the sole remedy of purchaser under this warranty. In no event will Simpson Strong-Tie Company Inc. be responsible for incidental, consequential, or special loss or damage, however caused.

This warranty is expressly in lieu of all other warranties, expressed or implied, including warranties of merchantability or fitness for a particular purpose, all such other warranties being hereby expressly excluded. This warranty may change periodically – consult our website www.strongtie.com for current information.

Terms and Conditions of Sale

Product Use

Products in this catalog are designed and manufactured for the specific purposes shown, and should not be used with other connectors not approved by a qualified Designer. Modifications to products or changes in installations should only be made by a qualified Designer. The performance of such modified products or altered installations is the sole responsibility of the Designer.

Indemnity

Customers or Designers modifying products or installations, or designing non-catalog products for fabrication by Simpson Strong-Tie Company Inc. shall, regardless of specific instructions to the user, indemnify, defend and hold harmless Simpson Strong-Tie Company Inc. for any and all claimed loss or damage occasioned in whole or in part by non-catalog or modified products.

Non-Catalog And Modified Products

Consult Simpson Strong-Tie Company Inc. for applications for which there is no catalog product, or for connectors for use in hostile environments, with excessive wood shrinkage, or with abnormal loading or erection requirements.

Non-catalog products must be designed by the customer and will be fabricated by Simpson Strong-Tie in accordance with customer specifications.

Simpson Strong-Tie cannot and does not make any representations regarding the suitability of use or load-carrying capacities of non-catalog products. Simpson Strong-Tie provides no warranty, express or implied, on non-catalog products. F.O.B. Shipping Point unless otherwise specified.

Important Information and General Notes

Warning

Simpson Strong-Tie Company Inc. anchors, fasteners and connectors are designed and tested to provide specified design loads. To obtain optimal performance from Simpson Strong-Tie products and to achieve maximum allowable design load, the products must be properly installed and used in accordance with the installation instructions and design limits provided by Simpson Strong-Tie. To ensure proper installation and use, designers and installers must carefully read the General Notes, General Instructions to the Installer and General Instructions to the Designer contained in this catalog, as well as consult the applicable catalog pages for specific product installation instructions and notes. Please always consult the Simpson Strong-Tie website at strongtie.com for updates regarding all Simpson Strong-Tie products.

Proper product installation requires careful attention to all notes and instructions, including the following basic rules:

1. Be familiar with the application and correct use of the anchor, connector or fastener.
2. Follow all installation instructions provided in the catalog, website, *Installer's Pocket Guide* or any other Simpson Strong-Tie publication.
3. Follow all product-related warnings provided in the catalog, website or any other Simpson Strong-Tie publication.
4. Install anchors, connectors and fasteners in accordance with their intended use.
5. Install all anchors, connectors and fasteners per installation instructions provided by Simpson Strong-Tie.
6. When using power tools to install fasteners:
 - (a) use proper fastener type for direct fastening tool; (b) use proper powder or gas loads; and (c) follow appropriate safety precautions as outlined in this catalog, on the website or in the tool Operator's Manual.

In addition to following the basic rules provided above as well as all notes, warnings and instructions provided in the catalog, installers, designers, engineers and consumers should consult the Simpson Strong-Tie website at www.strongtie.com to obtain additional design and installation information, including:

- Instructional builder/contractor training kits containing an instructional video, an instructor guide and a student guide in both English and Spanish;
- *Installer's Pocket Guide* (form S-INSTALL; contact Simpson Strong-Tie for more information), which is designed specifically for installers and uses detailed graphics and minimal text in both English and Spanish to explain visually how to install many key products;

- Information on workshops Simpson Strong-Tie conducts at various training centers throughout the United States;
- Product-specific installation videos;
- Specialty catalogs;
- Code reports – Simpson Strong-Tie® Code Report Finder software;
- Technical fliers, bulletins and engineering letters;
- Master format specifications;
- Material safety data sheets;
- Corrosion information;
- Adhesive cartridge estimator;
- Simpson Strong-Tie Anchor Designer™ software;
- Simpson Strong-Tie AutoCAD® menu;
- Simpson Strong-Tie CFS Designer™ software;
- Simpson Strong-Tie Connector Selector™ software;
- Connector selection guides for engineered wood products (by manufacturer);
- Simpson Strong-Tie Strong-Wall® Selector software;
- Simpson Strong-Tie Strong Frame® Selector;
- Simpson Strong-Tie Fastener Finder; and
- Answers to frequently asked questions and technical topics.

Failure to fully follow all of the notes and instructions provided by Simpson Strong-Tie may result in improper installation of products. Improperly installed products may not perform to the specifications set forth in this catalog and may reduce a structure's ability to resist the movement, stress and loading that occur from gravity loads as well as impact events such as earthquakes and high-velocity winds.

Simpson Strong-Tie Company Inc. does not guarantee the performance or safety of products that are modified, improperly installed or not used in accordance with the design and load limits set forth in this catalog.

Adhesive Anchors





From rebar doweling on a high-traffic infrastructure retrofit project to do-it-yourself projects, Simpson Strong-Tie offers a wide variety of adhesive anchoring products to meet virtually any need.

Our strong, versatile epoxy-based adhesives are ideal for anchoring threaded rod, rebar and smooth dowels in an assortment of base materials. And our acrylic formulations deliver consistent performance for high-strength anchor grouting in a wide range of weather conditions — curing fast even in water-saturated concrete.



AT-XP® High-Strength Acrylic Adhesive

Formulated for high-strength anchorage of threaded rod and rebar into cracked and uncracked concrete and masonry under a wide range of conditions, AT-XP® adhesive dispenses easily in cold or warm environments and in below-freezing temperatures with no need to warm the cartridge. When mixed properly, this low-odor formula is a dark teal color for easy post-installation identification.

Features

- Passed the demanding ICC-ES AC308 adverse-condition tests pertaining to reduced and elevated temperatures and long-term sustained loads
- Code listed under the IBC/IRC for cracked and uncracked concrete per IAPMO UES ER-263 and City of L.A. RR25960
- Code listed under the IBC/IRC for masonry per IAPMO UES ER-281 and City of L.A. RR25966
- 10:1 two-component high-strength, acrylic-based anchoring adhesive
- Suitable for use under static and seismic loading conditions in cracked and uncracked concrete as well as masonry
- Easy hole-cleaning procedure – no power-brushing required
- Suitable for use in dry or water-saturated concrete
- For best results, store between 14°F and 80°F
- Cures in substrate temperatures as low as 14°F (-10°C) in 24 hours or less
- Available in 9.4 oz., 12.5 oz. and 30 oz. cartridges for application versatility
- Volatile Organic Compound (VOC) – 30 g/L
- Manufactured in the USA using global materials

Applications

- Threaded rod anchoring and rebar doweling into concrete and masonry
- Suitable for horizontal, vertical and overhead applications

Codes: IAPMO UES ER-263 (concrete); IAPMO UES ER-281 (masonry); City of L.A. RR25960 (concrete), RR25966 (masonry); FL-16230.1; NSF/ANSI Standard 61 (43.2 in.²/1,000 gal.)

Chemical Resistance

See pages 320–321.

Installation and Application Instructions

(See also pages 124–127.)

- Surfaces to receive adhesive must be clean.
- Base material temperature must be 14°F or above at the time of installation. For best results, material should be 14–80°F at time of application.
- To warm cold material, store cartridges in a warm, uniformly heated area or storage container. Do not immerse cartridges in water to facilitate warming.
- Mixed material in nozzle can harden in 3–4 minutes at temperatures of 70°F and above.



AT-XP® Adhesive

Design Example

See page 328.

Suggested Specifications

See www.strongtie.com for more information.

AT-XP® High-Strength Acrylic Adhesive

AT-XP® Adhesive Cartridge System

Model No.	Capacity ounces (cubic in.)	Cartridge Type	Carton Qty.	Dispensing Tool	Mixing Nozzle
AT-XP10	9.4 (16.9)	Coaxial	6	CDT10S	AMN19Q
AT-XP13	12.5 (22.5)	Side-by-side	10	ADT813S	
AT-XP30	30 (54)	Side-by-side	5	ADT30S ADTA30P or ADTA30CKT	

1. Cartridge estimation guidelines are available at www.strongtie.com/apps.
2. Detailed information on dispensing tools, mixing nozzles and other adhesive accessories is available on pages 128 through 135 or at www.strongtie.com.
3. Use only Simpson Strong-Tie® mixing nozzles in accordance with Simpson Strong-Tie instructions. Modification or improper use of mixing nozzle may impair AT-XP adhesive performance.
4. One AMN19Q mixing nozzle and one nozzle extension are supplied with each cartridge.

Cure Schedule

Base Material Temperature		Cure Time (hrs.)
°F	°C	
14	-10	24
32	0	8
50	10	3
68	20	1
86	30	30 min.
100	38	20 min.

For water-saturated concrete, the cure times must be doubled.

AT-XP® Design Information — Concrete

AT-XP® Installation Information and Additional Data for Threaded Rod and Rebar in Normal-Weight Concrete¹



Characteristic	Symbol	Units	Nominal Anchor Diameter (in.) / Rebar Size							
			3/8 / #3	1/2 / #4	5/8 / #5	3/4 / #6	7/8 / #7	1 / #8	1 1/4 / #10	
Installation Information										
Drill Bit Diameter for Threaded Rod	d_{hole}	in.	7/16	9/16	1 1/16	1 3/16	1	1 1/8	1 3/8	
Drill Bit Diameter for Rebar	d_{hole}	in.	1/2	5/8	3/4	7/8	1	1 1/8	1 3/8	
Maximum Tightening Torque	T_{inst}	ft.-lb.	10	20	30	45	60	80	125	
Permitted Embedment Depth Range ²	Minimum	h_{ef}	in.	2 3/8	2 3/4	3 1/8	3 1/2	3 3/4	4	5
	Maximum	h_{ef}	in.	7 1/2	10	12 1/2	15	17 1/2	20	25
Minimum Concrete Thickness	h_{min}	in.	$h_{ef} + 5d_o$							
Critical Edge Distance ²	c_{ac}	in.	See footnote 2							
Minimum Edge Distance	c_{min}	in.	1 3/4						2 3/4	
Minimum Anchor Spacing	s_{min}	in.	3						6	

1. The information presented in this table is to be used in conjunction with the design criteria of ACI 318-11.

2. $c_{ac} = h_{ef} (\tau_{k,uncr} / 1160)^{0.4} \times [3.1 - 0.7(h/h_{ef})]$, where:

$$[h/h_{ef}] \leq 2.4$$

$\tau_{k,uncr}$ = the characteristic bond strength in uncracked concrete, given in the tables that follow $\leq k_{uncr} ((h_{ef} \times f'_c)^{0.5} / (\pi \times d_a))$

h = the member thickness (inches)

h_{ef} = the embedment depth (inches)

* See page 12 for an explanation of the load table icons.

AT-XP® Design Information — Concrete



AT-XP® Tension Strength Design Data for Threaded Rod in Normal-Weight Concrete¹

Characteristic		Symbol	Units	Nominal Anchor Diameter (in.)						
				3/8	1/2	5/8	3/4	7/8	1	1 1/4
Steel Strength in Tension										
Threaded Rod	Minimum Tensile Stress Area	A_{se}	in. ²	0.078	0.142	0.226	0.334	0.462	0.606	0.969
	Tension Resistance of Steel — ASTM F1554, Grade 36	N_{sa}	lb.	4,525	8,235	13,110	19,370	26,795	35,150	56,200
	Tension Resistance of Steel — ASTM A193, Grade B7			9,750	17,750	28,250	41,750	57,750	75,750	121,125
	Tension Resistance of Steel — Type 410 Stainless (ASTM A193, Grade B6)			8,580	15,620	24,860	36,740	50,820	66,660	106,590
	Tension Resistance of Steel — Type 304 and 316 Stainless (ASTM A193, Grade B8 & B8M)			4,445	8,095	12,880	19,040	26,335	34,540	55,235
Strength Reduction Factor — Steel Failure	ϕ	—	0.75 ⁶							
Concrete Breakout Strength in Tension (2,500 psi ≤ f_c ≤ 8,000 psi)										
Effectiveness Factor — Uncracked Concrete		k_{uncr}	—	24						
Effectiveness Factor — Cracked Concrete		k_{cr}	—	17						
Strength Reduction Factor — Breakout Failure		ϕ	—	0.65 ⁸						
Bond Strength in Tension (2,500 psi ≤ f_c ≤ 8,000 psi)										
Uncracked Concrete ^{2,3,4}	Characteristic Bond Strength	$\tau_{k,uncr}$	psi	1,390	1,590	1,715	1,770	1,750	1,655	1,250
	Permitted Embedment Depth Range	Minimum	h_{ef}	in.	2 3/8	2 3/4	3 1/8	3 1/2	3 3/4	4
Maximum		h_{ef}	in.	7 1/2	10	12 1/2	15	17 1/2	20	25
Cracked Concrete ^{2,3,4}	Characteristic Bond Strength ^{9,10,11}	$\tau_{k,cr}$	psi	1,085	1,035	980	950	815	800	700
	Permitted Embedment Depth Range	Minimum	h_{ef}	in.	3	3	3 1/8	3 1/2	3 3/4	4
Maximum		h_{ef}	in.	7 1/2	10	12 1/2	15	17 1/2	20	25
Bond Strength in Tension — Bond Strength Reduction Factors for Continuous Special Inspection										
Strength Reduction Factor — Dry Concrete		ϕ_{dry}	—	0.65 ⁷						
Strength Reduction Factor — Water-Saturated Concrete		ϕ_{sat}	—	0.45 ⁷						
Additional Factor for Water-Saturated Concrete		K_{sat}	—	0.54 ⁵			0.77 ⁵		0.96 ⁵	
Bond Strength in Tension — Bond Strength Reduction Factors for Periodic Special Inspection										
Strength Reduction Factor — Dry Concrete		ϕ_{dry}	—	0.55 ⁷						
Strength Reduction Factor — Water-Saturated Concrete		ϕ_{sat}	—	0.45 ⁷						
Additional Factor for Water-Saturated Concrete		K_{sat}	—	0.46 ⁵			0.65 ⁵		0.81 ⁵	

- The information presented in this table is to be used in conjunction with the design criteria of ACI 318-11.
- Temperature Range: Maximum short-term temperature of 180°F. Maximum long-term temperature of 110°F.
- Short-term concrete temperatures are those that occur over short intervals (diurnal cycling).
- Long-term concrete temperatures are constant temperatures over a significant time period.
- In water-saturated concrete, multiply $\tau_{k,uncr}$ and $\tau_{k,cr}$ by K_{sat} .
- The value of ϕ applies when the load combinations of ACI 318 Section 9.2 are used. If the load combinations of ACI 318 Appendix C are used, refer to Section D.4.4 to determine the appropriate value of ϕ .
- The value of ϕ applies when both the load combinations of ACI 318 Section 9.2 are used and the requirements of Section D.4.3 (c) for Condition B are met. If the load combinations of ACI 318 Appendix C are used, refer to Section D.4.4 to determine the appropriate value of ϕ .
- The value of ϕ applies when both the load combinations of ACI 318 Section 9.2 are used and the requirements of Section D.4.3 (c) for Condition B are met. If the load combinations of ACI 318 Appendix C are used, refer to Section D.4.4 to determine the appropriate value of ϕ .
- The value of ϕ applies when both the load combinations of ACI 318 Section 9.2 are used and the requirements of Section D.4.3 (c) for Condition B are met. If the load combinations of ACI 318 Appendix C are used, refer to Section D.4.4 to determine the appropriate value of ϕ .
- For anchors installed in regions assigned to Seismic Design Category C, D, E or F, the bond strength values for 1/2", 3/8", 3/4" and 1" anchors must be multiplied by $\alpha_{N,seis} = 0.85$.
- For anchors installed in regions assigned to Seismic Design Category C, D, E or F, the bond strength values for 1 1/4" anchors must be multiplied by $\alpha_{N,seis} = 0.75$.
- For anchors installed in regions assigned to Seismic Design Category C, D, E or F, the bond strength values for 7/8" anchors must be multiplied by $\alpha_{N,seis} = 0.59$.

C-A-2016 © 2015 SIMPSON STRONG-TIE COMPANY INC.

Adhesive Anchors

* See page 12 for an explanation of the load table icons.

AT-XP® Design Information — Concrete

AT-XP® Tension Strength Design Data for Rebar in Normal-Weight Concrete¹



Adhesive Anchors

Characteristic		Symbol	Units	Rebar Size							
				#3	#4	#5	#6	#7	#8	#10	
Steel Strength in Tension											
Rebar	Minimum Tensile Stress Area	A_{se}	in. ²	0.11	0.2	0.31	0.44	0.6	0.79	1.27	
	Tension Resistance of Steel — Rebar (ASTM A615 Grade 60)	N_{sa}	lb.	9,900	18,000	27,900	39,600	54,000	71,100	114,300	
	Tension Resistance of Steel — Rebar (ASTM A706 Grade 60)			8,800	16,000	24,800	35,200	48,000	63,200	101,600	
	Strength Reduction Factor — Steel Failure	ϕ	—	0.75 ⁶							
Concrete Breakout Strength in Tension (2,500 psi ≤ f'_c ≤ 8,000 psi)											
Effectiveness Factor — Uncracked Concrete		k_{uncr}	—	24							
Effectiveness Factor — Cracked Concrete		k_{cr}	—	17							
Strength Reduction Factor — Breakout Failure		ϕ	—	0.65 ⁸							
Bond Strength in Tension (2,500 psi ≤ f'_c ≤ 8,000 psi)											
Uncracked Concrete ^{2,3,4}	Characteristic Bond Strength		$\tau_{k,uncr}$	psi	1,010	990	970	955	935	915	875
	Permitted Embedment Depth Range	Minimum	h_{ef}	in.	2 ³ / ₈	2 ³ / ₄	3 ¹ / ₈	3 ¹ / ₂	3 ³ / ₄	4	5
		Maximum			7 ¹ / ₂	10	12 ¹ / ₂	15	17 ¹ / ₂	20	25
Cracked Concrete ^{2,3,4}	Characteristic Bond Strength		$\tau_{k,cr}$	psi	340	770	780	790	795	795	820
	Permitted Embedment Depth Range	Minimum	h_{ef}	in.	3	3	3 ¹ / ₈	3 ¹ / ₂	3 ³ / ₄	4	5
		Maximum			7 ¹ / ₂	10	12 ¹ / ₂	15	17 ¹ / ₂	20	25
Bond Strength in Tension — Bond Strength Reduction Factors for Continuous Special Inspection											
Strength Reduction Factor — Dry Concrete		ϕ_{dry}	—	0.65 ⁷					0.55 ⁷		
Strength Reduction Factor — Water-Saturated Concrete		ϕ_{sat}	—	0.45 ⁷							
Additional Factor for Water-Saturated Concrete		K_{sat}	—	0.54 ⁵		0.77 ⁵			0.96 ⁵		
Bond Strength in Tension — Bond Strength Reduction Factors for Periodic Special Inspection											
Strength Reduction Factor — Dry Concrete		ϕ_{dry}	—	0.55 ⁷					0.45 ⁷		
Strength Reduction Factor — Water-Saturated Concrete		ϕ_{sat}	—	0.45 ⁷							
Additional Factor for Water-Saturated Concrete		K_{sat}	—	0.46 ⁵		0.65 ⁵			0.81 ⁵		

- The information presented in this table is to be used in conjunction with the design criteria of ACI 318-11.
- Temperature Range: Maximum short-term temperature of 180°F. Maximum long-term temperature of 110°F.
- Short-term concrete temperatures are those that occur over short intervals (diurnal cycling).
- Long-term concrete temperatures are constant temperatures over a significant time period.
- In water-saturated concrete, multiply $\tau_{k,uncr}$ and $\tau_{k,cr}$ by K_{sat} .
- The value of ϕ applies when the load combinations of ACI 318 Section 9.2 are used. If the load combinations of ACI 318 Appendix C are used, refer to Section D.4.4 to determine the appropriate value of ϕ .

- The value of ϕ applies when both the load combinations of ACI 318 Section 9.2 are used and the requirements of Section D.4.3 (c) for Condition B are met. If the load combinations of ACI 318 Appendix C are used, refer to Section D.4.4 to determine the appropriate value of ϕ .
- The value of ϕ applies when both the load combinations of ACI 318 Section 9.2 are used and the requirements of Section D.4.3 (c) for Condition B are met. If the load combinations of ACI 318 Section 9.2 are used and the requirements of Section D.4.3 (c) for Condition A are met, refer to Section D.4.3 to determine the appropriate value of ϕ . If the load combinations of ACI 318 Appendix C are used, refer to Section D.4.4 to determine the appropriate value of ϕ .

* See page 12 for an explanation of the load table icons.

AT-XP® Design Information — Concrete

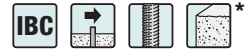
AT-XP® Shear Strength Design Data for Threaded Rod in Normal-Weight Concrete¹

Characteristic		Symbol	Units	Nominal Anchor Diameter (in.)						
				3/8	1/2	5/8	3/4	7/8	1	1 1/4
Steel Strength in Shear										
Threaded Rod	Minimum Shear Stress Area	A_{se}	in. ²	0.078	0.142	0.226	0.334	0.462	0.606	0.969
	Shear Resistance of Steel — ASTM F1554, Grade 36	V_{sa}	lb.	2,260	4,940	7,865	11,625	16,080	21,090	33,720
	Shear Resistance of Steel — ASTM A193, Grade B7			4,875	10,650	16,950	25,050	34,650	45,450	72,675
	Shear Resistance of Steel — Type 410 Stainless (ASTM A193, Grade B6)	V_{sa}	lb.	4,290	9,370	14,910	22,040	30,490	40,000	63,955
	Shear Resistance of Steel — Type 304 and 316 Stainless (ASTM A193, Grade B8 & B8M)			2,225	4,855	7,730	11,425	15,800	20,725	33,140
	Reduction for Seismic Shear — ASTM F1554, Grade 36	$\alpha_{V,seis}^5$	—	0.85						
	Reduction for Seismic Shear — ASTM A193, Grade B7			0.85						
	Reduction for Seismic Shear — Type 410 Stainless (ASTM A193, Grade B6)	$\alpha_{V,seis}^5$	—	0.85	0.75					0.85
	Reduction for Seismic Shear — Type 304 and 316 Stainless (ASTM A193, Grade B8 & B8M)			0.85	0.75					0.85
	Strength Reduction Factor — Steel Failure	ϕ	—	0.65 ²						
Concrete Breakout Strength in Shear										
Outside Diameter of Anchor	d_o	in.	0.375	0.5	0.625	0.75	0.875	1	1.25	
Load-Bearing Length of Anchor in Shear	ℓ_e	in.	h_{eff}							
Strength Reduction Factor — Breakout Failure	ϕ	—	0.70 ³							
Concrete Pryout Strength in Shear										
Coefficient for Pryout Strength	k_{cp}	—	1.0 for $h_{eff} < 2.50"$; 2.0 for $h_{eff} \geq 2.50"$							
Strength Reduction Factor — Pryout Failure	ϕ	—	0.70 ⁴							

1. The information presented in this table is to be used in conjunction with the design criteria of ACI 318-11.

2. The value of ϕ applies when the load combinations of ACI 318 Section 9.2 are used. If the load combinations of ACI 318 Appendix C are used, refer to Section D.4.4 to determine the appropriate value of ϕ .

3. The value of ϕ applies when both the load combinations of ACI 318 Section 9.2 are used and the requirements of Section D.4.3 (c) for Condition B are met. If the load combinations of ACI 318 Section 9.2 are used and the requirements of Section D.4.3 (c) for Condition A are met, refer to Section D.4.3 to determine the appropriate value of ϕ . If the load combinations of ACI 318 Appendix C are used, refer to Section D.4.4 to determine the appropriate value of ϕ .

4. The value of ϕ applies when both the load combinations of ACI 318 Section 9.2 are used and the requirements of Section D.4.3 (c) for Condition B are met. If the load combinations of ACI 318 Appendix C are used, refer to Section D.4.4 to determine the appropriate value of ϕ .

5. The values of V_{sa} are applicable for both cracked concrete and uncracked concrete. For anchors installed in regions assigned to Seismic Design Category C, D, E or F, V_{sa} must be multiplied by $\alpha_{V,seis}$ for the corresponding anchor steel type.

AT-XP® Design Information — Concrete

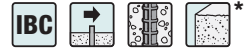

AT-XP® Shear Strength Design Data for Rebar in Normal-Weight Concrete¹

Characteristic		Symbol	Units	Rebar Size							
				#3	#4	#5	#6	#7	#8	#10	
Steel Strength in Shear											
Rebar	Minimum Shear Stress Area	A_{se}	in. ²	0.11	0.2	0.31	0.44	0.6	0.79	1.27	
	Shear Resistance of Steel — Rebar (ASTM A615 Grade 60)	V_{sa}	lb.	4,950	10,800	16,740	23,760	32,400	42,660	68,580	
	Shear Resistance of Steel — Rebar (ASTM A706 Grade 60)			4,400	9,600	14,880	21,120	28,800	37,920	60,960	
	Reduction for Seismic Shear — Rebar (ASTM A615 Grade 60)	$\alpha_{V,seis}^5$	—	0.56				0.80			
	Reduction for Seismic Shear — Rebar (ASTM A706 Grade 60)			0.56				0.80			
	Strength Reduction Factor — Steel Failure	ϕ	—	0.65 ²							
Concrete Breakout Strength in Shear											
	Outside Diameter of Anchor	d_o	in.	0.375	0.5	0.625	0.75	0.875	1	1.25	
	Load-Bearing Length of Anchor in Shear	ℓ_e	in.	h_{ef}							
	Strength Reduction Factor — Breakout Failure	ϕ	—	0.70 ³							
Concrete Pryout Strength in Shear											
	Coefficient for Pryout Strength	k_{cp}	—	1.0 for $h_{ef} < 2.50"$; 2.0 for $h_{ef} \geq 2.50"$							
	Strength Reduction Factor — Pryout Failure	ϕ	—	0.70 ⁴							

- The information presented in this table is to be used in conjunction with the design criteria of ACI 318-11.
- The value of ϕ applies when the load combinations of ACI 318 Section 9.2 are used. If the load combinations of ACI 318 Appendix C are used, refer to Section D.4.4 to determine the appropriate value of ϕ .
- The value of ϕ applies when both the load combinations of ACI 318 Section 9.2 are used and the requirements of Section D.4.3 (c) for Condition B are met. If the load combinations of ACI 318 Section 9.2 are used and the requirements of Section D.4.3 (c) for Condition A are met, refer to Section D.4.3 to determine the appropriate value of ϕ . If the load combinations of ACI 318 Appendix C are used, refer to Section D.4.4 to determine the appropriate value of ϕ .

- The value of ϕ applies when both the load combinations of ACI 318 Section 9.2 are used and the requirements of Section D.4.3 (c) for Condition B are met. If the load combinations of ACI 318 Appendix C are used, refer to Section D.4.4 to determine the appropriate value of ϕ .
- The values of V_{sa} are applicable for both cracked concrete and uncracked concrete. For anchors installed in regions assigned to Seismic Design Category C, D, E or F, V_{sa} must be multiplied by $\alpha_{V,seis}$ for the corresponding anchor steel type.

* See page 12 for an explanation of the load table icons.

AT-XP® Design Information — Concrete

AT-XP® Tension Design Strengths for Threaded Rod Anchors
in Normal-Weight Concrete ($f'_c = 2,500$ psi)

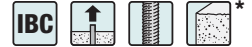

Rod Dia. (in.)	Nominal Embed. Depth (in.)	Minimum Dimensions for Uncracked (in.)		Minimum Dimensions for Cracked (in.)		Tension Design Strength Based on Concrete or Bond (lb.)							
		h_a	C_{ac}	h_a	C_{ac}	Edge Distances = C_{ac} on all sides				Edge Distances = $1\frac{3}{4}$ " on one side and C_{ac} on three sides			
						SDC A-B ⁶		SDC C-F ^{7,8}		SDC A-B ⁶		SDC C-F ^{7,8}	
		Uncracked	Cracked	Uncracked	Cracked	Uncracked	Cracked	Uncracked	Cracked	Uncracked	Cracked		
3/8	2 3/8	4 1/4	4 3/4	—	—	2,140	—	1,605	—	1,115	—	835	—
		5 3/4	4 1/4	—	—	—	—	—	—	1,250	—	935	—
	3	4 7/8	6 3/8	4 7/8	4 1/4	2,700	2,110	2,025	1,580	1,050	1,230	790	925
		7 1/4	4 5/8	—	—	—	—	—	—	1,450	—	1,090	—
	4 1/2	6 3/8	10 1/4	6 3/8	5 1/4	4,055	3,165	3,040	2,375	975	1,845	735	1,385
		10 7/8	6 7/8	—	—	—	—	—	—	1,450	—	1,090	—
6	7 7/8	14 1/8	7 7/8	6	5,405	4,220	4,055	3,165	945	2,250	710	1,685	
	14 1/2	9 1/4	—	—	—	—	—	—	1,450	—	1,090	—	
7 1/2	9 3/8	18	9 3/8	6 3/4	6,755	5,275	5,065	3,955	925	2,585	695	1,935	
	18	11 1/2	—	—	—	—	—	—	1,450	—	1,090	—	
1/2	2 3/4	5 1/4	6 1/8	—	—	3,555	—	2,410	—	1,720	—	1,225	—
		6 3/8	6 1/8	—	—	—	—	—	—	1,920	—	1,225	—
	3	5 1/2	6 1/8	5 1/2	6 1/8	4,055	2,680	2,625	1,710	1,800	1,365	1,335	870
		7 1/4	6 1/8	—	—	—	—	—	—	2,095	—	1,335	—
	6	8 1/2	14 3/8	8 1/2	7	8,240	5,365	5,255	3,420	1,755	2,700	1,120	1,740
		14 1/2	9 3/4	—	—	—	—	—	—	2,605	—	1,660	—
8	10 1/2	19 7/8	10 1/2	8 1/2	10,990	7,155	7,005	4,560	1,695	3,425	1,080	2,320	
	19 1/4	13	—	—	—	—	—	—	2,605	—	1,660	—	
10	12 1/2	25 1/4	12 1/2	9 3/4	13,735	8,940	8,755	5,700	1,665	4,070	1,060	2,895	
	24	16 1/8	—	—	—	—	—	—	2,605	—	1,660	—	
5/8	3 1/8	6 1/4	7 7/8	6 1/4	7 5/8	4,310	3,050	3,230	1,995	2,180	1,485	1,635	950
		7 1/2	7 7/8	—	—	—	—	—	—	2,405	—	1,735	—
	5	8 1/8	10 1/2	8 1/8	7 7/8	8,720	5,285	5,905	3,370	2,965	2,485	2,065	1,585
		12	7 7/8	—	—	—	—	—	—	4,095	—	2,770	—
7 1/2	10 3/8	18 3/8	10 3/8	9 1/8	13,890	7,935	8,855	5,060	2,780	3,705	1,770	2,375	
	18	12 3/8	—	—	—	—	—	—	4,130	—	2,630	—	
12 1/2	15 5/8	32 5/8	15 5/8	12 1/2	23,150	13,230	14,760	8,435	2,610	5,620	1,665	3,960	
	30	20 7/8	—	—	—	—	—	—	4,090	—	2,605	—	
3/4	3 1/2	7 1/4	9 5/8	7 1/4	8 7/8	5,105	3,620	3,830	2,340	2,680	1,695	2,010	1,080
		8 1/2	9 5/8	—	—	—	—	—	—	2,725	—	2,045	—
	6	9 3/4	12 1/8	9 3/4	9 5/8	11,465	7,380	8,600	4,705	3,855	3,300	2,890	2,105
		14 1/2	9 5/8	—	—	—	—	—	—	5,190	—	3,895	—
9	12 3/4	21 1/4	12 3/4	11 1/4	20,645	11,080	13,160	7,065	4,145	4,895	2,640	3,160	
	21 5/8	14 3/8	—	—	—	—	—	—	6,155	—	3,925	—	
15	18 3/4	39 3/8	18 3/4	15 3/4	34,405	18,465	21,935	11,775	3,705	7,660	2,360	5,265	
	36	25 1/4	—	—	—	—	—	—	5,800	—	3,700	—	
7/8	3 3/4	8 1/8	11 1/8	8 1/8	10 1/2	5,665	4,010	4,250	1,825	2,945	1,825	1,900	805
		9	11 1/8	—	—	—	—	—	—	2,945	—	1,900	—
	7	11 3/8	13 3/4	11 3/8	11 1/8	14,445	8,625	8,195	3,815	4,840	3,735	2,855	1,655
		16 7/8	11 1/8	—	—	—	—	—	—	6,320	—	3,550	—
10 1/2	14 7/8	24	14 7/8	12 1/2	26,540	12,940	12,295	5,725	5,540	5,605	2,450	2,480	
	25 1/4	16 1/4	—	—	—	—	—	—	8,225	—	3,640	—	
17 1/2	21 7/8	46	21 7/8	17 1/2	46,300	21,565	20,490	9,540	4,820	8,840	2,135	4,130	
	42	29 3/8	—	—	—	—	—	—	7,555	—	3,345	—	
1	4	9	12 3/8	9	12 3/8	6,240	4,420	4,680	2,885	3,175	1,920	2,380	1,225
		9 3/8	12 3/8	—	—	—	—	—	—	3,175	—	2,380	—
	8	13	15 3/8	13	12 3/8	17,650	9,050	11,935	5,770	5,915	3,840	4,070	2,450
		19 1/4	12 3/8	—	—	—	—	—	—	7,520	—	5,065	—
12	17	26 3/4	17	12 3/4	28,075	13,570	17,900	8,650	5,480	5,760	3,495	3,670	
	28 3/8	18	—	—	—	—	—	—	8,135	—	5,185	—	
20	25	51 3/8	25	18 1/4	46,795	22,620	29,830	14,420	4,750	9,365	3,025	6,120	
	48	32 3/4	—	—	—	—	—	—	7,440	—	4,745	—	
1 1/4	5	11 1/4	13 3/8	11 1/4	13 3/8	8,720	6,175	6,215	3,480	—	—	—	—
		12	13 3/8	—	—	—	—	—	—	—	—	—	—
	10	16 1/4	18 1/4	16 1/4	13 3/8	22,090	12,370	12,425	6,960	—	—	—	—
		24	15	—	—	—	—	—	—	—	—	—	—
15	21 1/4	32	21 1/4	15 3/4	33,135	18,555	18,640	10,435	—	—	—	—	
	36	22 1/2	—	—	—	—	—	—	—	—	—	—	
25	31 1/4	57 3/8	31 1/4	22	55,225	30,925	31,065	17,395	—	—	—	—	
	60	37 1/2	—	—	—	—	—	—	—	—	—	—	

Threaded Rod Dia. (in.)	Tension Design Strength of Threaded Rod Steel (lb.)					
	ASTM F1554 GR 36	ASTM F1554 GR 55	ASTM F1554 GR 105	ASTM A193 B6	ASTM A193 B7	ASTM A193 B8/B8M
3/8	3,370	4,360	7,270	6,395	7,270	3,310
1/2	6,175	7,990	13,315	11,715	13,315	6,070
5/8	9,835	12,715	21,190	18,645	21,190	9,660
3/4	14,530	18,790	31,315	27,555	31,315	14,280
7/8	20,095	25,990	43,315	38,115	43,315	19,750
1	26,365	34,090	56,815	49,995	56,815	25,905
1 1/4	42,150	54,505	90,845	79,945	90,845	41,425

- Tension design strength must be the lesser of the concrete, bond or threaded rod steel design strength.
- Tension design strengths are based on the strength design provisions of ACI 318-11 Appendix D assuming dry concrete, periodic inspection, short-term temperature of 180°F and long-term temperature of 110°F.
- Tabulated values are for a single anchor with no influence of another anchor.
- Interpolation between embedment depths is not permitted.
- Strength reduction factor, ϕ , is based on using a load combination from ACI 318-11 Section 9.2.
- The tension design strength listed for SDC (Seismic Design Category) A-B may also be used in SDC C-F when the tension component of the strength-level seismic design load on the anchor does not exceed 20% of the total factored tension load on the anchor associated with the same load combination.
- When designing anchorages in SDC C-F, the Designer shall consider the ductility requirements of ACI 318-11 Section D.3.3. Design strengths in **Bold** indicate that the anchor ductility requirements of D.3.3.4.3 (a)1 to 3 are satisfied when using ASTM F1554 Grade 36 threaded rod. Any other ductility requirements must be satisfied.
- Tension design strengths in SDC C-F have been adjusted by 0.75 factor in accordance with ACI 318-11 Section D.3.3.4.4.

* See page 12 for an explanation of the load table icons.

AT-XP® Design Information — Concrete

AT-XP® Allowable Tension Loads for Threaded Rod Anchors in Normal-Weight Concrete
(f'c = 2,500 psi) — Static Load

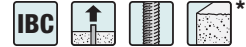

Adhesive Anchors

Rod Dia. (in.)	Nominal Embed. Depth (in.)	Minimum Dimensions for Uncracked (in.)		Minimum Dimensions for Cracked (in.)		Allowable Tension Load Based on Concrete or Bond (lb.)			
		ha	Cac	ha	Cac	Edge distances = cac on all sides		Edge Distances = 1 3/4" on one side and cac on three sides	
						Uncracked	Cracked	Uncracked	Cracked
3/8	2 3/8	4 1/4	4 3/4	—	—	1,530	—	795	—
		5 3/4	4 1/4	—	—			895	—
	3	4 7/8	6 3/8	4 7/8	4 1/4	1,930	1,505	750	880
		7 1/4	4 5/8	—	—			1,035	—
	4 1/2	6 3/8	10 1/4	6 3/8	5 1/4	2,895	2,260	695	1,320
		10 7/8	6 7/8	—	—			1,035	—
6	7 7/8	14 1/8	7 7/8	6	3,860	3,015	675	1,605	
	14 1/2	9 1/4	—	—			1,035	—	
7 1/2	9 3/8	18	9 3/8	6 3/4	4,825	3,770	660	1,845	
	18	11 1/2	—	—			1,035	—	
1/2	2 3/4	5 1/4	6 1/8	—	—	2,540	—	1,230	—
		6 3/8	6 1/8	—	—			1,370	—
	3	5 1/2	6 1/8	5 1/2	6 1/8	2,895	1,915	1,285	975
		7 1/4	6 1/8	—	—			1,495	—
	6	8 1/2	14 3/8	8 1/2	7	5,885	3,830	1,255	1,930
		14 1/2	9 3/4	—	—			1,860	—
8	10 1/2	19 7/8	10 1/2	8 1/2	7,850	5,110	1,210	2,445	
	19 1/4	13	—	—			1,860	—	
10	12 1/2	25 1/4	12 1/2	9 3/4	9,810	6,385	1,190	2,905	
	24	16 1/8	—	—			1,860	—	
5/8	3 1/8	6 1/4	7 7/8	6 1/4	7 7/8	3,080	2,180	1,555	1,060
		7 1/2	7 7/8	—	—			1,720	—
	5	8 1/8	10 1/2	8 1/8	7 7/8	6,230	3,775	2,120	1,775
		12	7 7/8	—	—			2,925	—
7 1/2	10 5/8	18 3/8	10 5/8	9 1/8	9,920	5,670	1,985	2,645	
	18	12 3/8	—	—			2,950	—	
12 1/2	15 5/8	32 3/8	15 5/8	12 1/2	16,535	9,450	1,865	4,015	
	30	20 7/8	—	—			2,920	—	
3/4	3 1/2	7 1/4	9 5/8	7 1/4	8 7/8	3,645	2,585	1,915	1,210
		8 1/2	9 5/8	—	—			1,945	—
	6	9 3/4	12 1/8	9 3/4	9 5/8	8,190	5,270	2,755	2,355
		14 1/2	9 5/8	—	—			3,705	—
	9	12 3/4	21 1/4	12 3/4	11 1/4	14,745	7,915	2,960	3,495
21 5/8		14 3/8	—	—	4,395			—	
15	18 3/4	39 5/8	18 3/4	15 3/4	24,575	13,190	2,645	5,470	
	36	25 1/4	—	—			4,145	—	
7/8	3 3/4	8 1/8	11 1/8	8 1/8	10 1/2	4,045	2,865	2,105	1,305
		9	11 1/8	—	—			2,105	—
	7	11 3/8	13 3/4	11 3/8	11 1/8	10,320	6,160	3,455	2,670
		16 7/8	11 1/8	—	—			4,515	—
	10 1/2	14 7/8	24	14 7/8	12 1/2	18,955	9,245	3,955	4,005
25 1/4		16 1/4	—	—	5,875			—	
17 1/2	21 7/8	46	21 7/8	17 1/2	33,070	15,405	3,445	6,315	
	42	29 3/8	—	—			5,395	—	
1	4	9	12 3/8	9	12 3/8	4,455	3,155	2,270	1,370
		9 3/8	12 3/8	—	—			2,270	—
	8	13	15 3/8	13	12 3/8	12,605	6,465	4,225	2,745
		19 1/4	12 3/8	—	—			5,370	—
12	17	26 3/4	17	12 3/4	20,055	9,695	3,915	4,115	
	28 7/8	18	—	—			5,810	—	
20	25	51 3/8	25	18 1/4	33,425	16,155	3,395	6,690	
	48	32 3/4	—	—			5,315	—	
1 1/4	5	11 1/4	13 3/8	11 1/4	13 3/8	6,230	4,410	—	—
		12	13 3/8	—	—			—	—
	10	16 1/4	18 1/4	16 1/4	13 3/8	15,780	8,835	—	—
		24	15	—	—			—	—
	15	21 1/4	32	21 1/4	15 3/4	23,670	13,255	—	—
36		22 1/2	—	—	—			—	
25	31 1/4	57 3/8	31 1/4	22	39,445	22,090	—	—	
	60	37 1/2	—	—			—	—	

Threaded Rod Dia. (in.)	Allowable Tension Load of Threaded Rod Steel (lb.)					
	ASTM F1554 GR 36	ASTM F1554 GR 55	ASTM F1554 GR 105	ASTM A193 B6	ASTM A193 B7	ASTM A193 B8/B8M
3/8	2,405	3,115	5,195	4,570	5,195	2,365
1/2	4,410	5,705	9,510	8,370	9,510	4,335
5/8	7,025	9,080	15,135	13,320	15,135	6,900
3/4	10,380	13,420	22,370	19,680	22,370	10,200
7/8	14,355	18,565	30,940	27,225	30,940	14,105
1	18,830	24,350	40,580	35,710	40,580	18,505
1 1/4	30,105	38,930	64,890	57,105	64,890	29,590

1. Allowable tension load must be the lesser of the concrete, bond or threaded rod steel load.
2. Allowable tension loads are calculated based on the strength design provisions of ACI 318-11 Appendix D assuming dry concrete, periodic inspection, short-term temperature of 180°F and long-term temperature of 110°F. Tension design strengths are converted to allowable tension loads using a conversion factor of $\alpha = 1.4$. The conversion factor α is based on the load combination 1.2D + 1.6L assuming 50% dead load and 50% live load: $1.2(0.5) + 1.6(0.5) = 1.4$.
3. Tabulated values are for a single anchor with no influence of another anchor.
4. Interpolation between embedment depths is not permitted.

* See page 12 for an explanation of the load table icons.

AT-XP® Design Information — Concrete

AT-XP® Allowable Tension Loads for Threaded Rod Anchors in Normal-Weight Concrete (f'c = 2,500 psi) — Wind Load

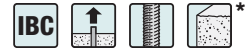

Rod Dia. (in.)	Nominal Embed. Depth (in.)	Minimum Dimensions for Uncracked (in.)		Minimum Dimensions for Cracked (in.)		Allowable Tension Load Based on Concrete or Bond (lb.)			
		ha	cac	ha	cac	Edge distances = cac on all sides		Edge Distances = 1¼" on one side and cac on three sides	
						Uncracked	Cracked	Uncracked	Cracked
¾	2¾	4¼	4¾	—	—	1,285	—	670	—
		5¾	4¼	—	—			750	—
	3	4¾	6¾	4¾	4¼	1,620	1,265	630	740
		7¼	4¾	—	—			870	—
	4½	6¾	10¼	6¾	5¼	2,435	1,900	585	1,105
		10¾	6¾	—	—			870	—
6	7¾	14 ½	7¾	6	3,245	2,530	565	1,350	
	14 ½	9¼	—	—			870	—	
7½	9¾	18	9¾	6¾	4,055	3,165	555	1,550	
	18	11 ½	—	—			870	—	
½	2¾	5¼	6¾	—	—	2,135	—	1,030	—
		6¾	6¾	—	—			1,150	—
	3	5½	6¾	5½	6¾	2,435	1,610	1,080	820
		7¼	6¾	—	—			1,255	—
	6	8½	14¾	8½	7	4,945	3,220	1,055	1,620
		14 ½	9¾	—	—			1,565	—
8	10½	19¾	10½	8½	6,595	4,295	1,015	2,055	
	19¼	13	—	—			1,565	—	
10	12½	25¼	12½	9¾	8,240	5,365	1,000	2,440	
	24	16¾	—	—			1,565	—	
5/8	3½	6¼	7¾	6¼	7¾	2,585	1,830	1,310	890
		7½	7¾	—	—			1,445	—
	5	8½	10½	8½	7¾	5,230	3,170	1,780	1,490
		12	7¾	—	—			2,455	—
7½	10¾	18¾	10¾	9½	8,335	4,760	1,670	2,225	
	18	12¾	—	—			2,480	—	
12½	15¾	32¾	15¾	12½	13,890	7,940	1,565	3,370	
	30	20¾	—	—			2,455	—	
¾	3½	7¼	9¾	7¼	8¾	3,065	2,170	1,610	1,015
		8½	9¾	—	—			1,635	—
	6	9¾	12 ½	9¾	9¾	6,880	4,430	2,315	1,980
		14 ½	9¾	—	—			3,115	—
9	12¾	21¼	12¾	11¼	12,385	6,650	2,485	2,935	
	21¾	14¾	—	—			3,695	—	
15	18¾	39¾	18¾	15¾	20,645	11,080	2,225	4,595	
	36	25¼	—	—			3,480	—	
7/8	3¾	8½	11 ½	8½	10½	3,400	2,405	1,765	1,095
		9	11 ½	—	—			1,765	—
	7	11¾	13¾	11¾	11¾	8,665	5,175	2,905	2,240
		16¾	11 ½	—	—			3,790	—
10½	14¾	24	14¾	12½	15,925	7,765	3,325	3,365	
	25¼	16¼	—	—			4,935	—	
17½	21¾	46	21¾	17½	27,780	12,940	2,890	5,305	
	42	29¾	—	—			4,535	—	
1	4	9	12¾	9	12¾	3,745	2,650	1,905	1,150
		9¾	12¾	—	—			1,905	—
	8	13	15¾	13	12¾	10,590	5,430	3,550	2,305
		19¼	12¾	—	—			4,510	—
12	17	26¾	17	12¾	16,845	8,140	3,290	3,455	
	28¾	18	—	—			4,880	—	
20	25	51¾	25	18¼	28,075	13,570	2,850	5,620	
	48	32¾	—	—			4,465	—	
1¼	5	11¼	13¾	11¼	13¾	5,230	3,705	—	—
		12	13¾	—	—			—	—
	10	16¼	18¼	16¼	13¾	13,255	7,420	—	—
		24	15	—	—			—	—
15	21¼	32	21¼	15¾	19,880	11,135	—	—	
	36	22½	—	—			—	—	
25	31¼	57¾	31¼	22	33,135	18,555	—	—	
	60	37½	—	—			—	—	

Threaded Rod Dia. (in.)	Allowable Tension Load of Threaded Rod Steel (lb.)					
	ASTM F1554 GR 36	ASTM F1554 GR 55	ASTM F1554 GR 105	ASTM A193 B6	ASTM A193 B7	ASTM A193 B8/B8M
¾	2,020	2,615	4,360	3,835	4,360	1,985
½	3,705	4,795	7,990	7,030	7,990	3,640
5/8	5,900	7,630	12,715	11,185	12,715	5,795
¾	8,720	11,275	18,790	16,535	18,790	8,570
7/8	12,055	15,595	25,990	22,870	25,990	11,850
1	15,820	20,455	34,090	29,995	34,090	15,545
1¼	25,290	32,705	54,505	47,965	54,505	24,855

1. Allowable tension load must be the lesser of the concrete, bond or threaded rod steel load.
2. Allowable tension loads are calculated based on the strength design provisions of ACI 318-11 Appendix D assuming dry concrete, periodic inspection, short-term temperature of 180°F and long-term temperature of 110°F. Tension design strengths are converted to allowable tension loads using a conversion factor of $\alpha = 1/1.67 = 0.6$. The conversion factor α is based on the load combination assuming 100% wind load.
3. Tabulated values are for a single anchor with no influence of another anchor.
4. Interpolation between embedment depths is not permitted.

* See page 12 for an explanation of the load table icons.

AT-XP® Design Information — Concrete

AT-XP® Allowable Tension Loads for Threaded Rod Anchors in Normal-Weight Concrete (f'_c = 2,500 psi) — Seismic Load

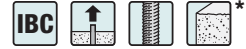

Adhesive Anchors

Nom. Insert Dia. (in.)	Embed. Depth, h _{ef} (in.)	Minimum Dimensions for Uncracked (in.)		Minimum Dimensions for Cracked (in.)		Allowable Tension Load Based on Concrete or Bond (lb.)							
						Edge Distances = c _{ac} on all sides				Edge Distances = 1 3/4" on one side and c _{ac} on three sides			
						SDC A-B ⁵		SDC C-F ^{6,7}		SDC A-B ⁵		SDC C-F ^{6,7}	
						Uncracked	Cracked	Uncracked	Cracked	Uncracked	Cracked	Uncracked	Cracked
3/8	2 3/8	4 1/4	4 3/4	—	—	1,500	—	1,125	—	780	—	585	—
		5 3/4	4 3/4	—	—	—	—	—	—	875	—	655	—
	3	4 7/8	6 3/8	4 7/8	4 1/4	1,890	1,475	1,420	1,105	735	860	555	650
		7 1/4	4 3/4	—	—	—	—	—	—	1,015	—	765	—
	4 1/2	6 3/8	10 1/4	6 3/8	5 1/4	2,840	2,215	2,130	1,665	685	1,290	515	970
		10 7/8	6 3/8	—	—	—	—	—	—	1,015	—	765	—
6	7 7/8	14 3/8	7 7/8	6	3,785	2,955	2,840	2,215	660	1,575	495	1,180	
	14 1/2	9 3/4	—	—	—	—	—	—	1,015	—	765	—	
7 1/2	9 3/8	18	9 3/8	6 3/4	4,730	3,695	3,545	2,770	650	1,810	485	1,355	
	18	11 1/2	—	—	—	—	—	—	1,015	—	765	—	
1/2	2 3/4	5 1/4	6 1/8	—	—	2,490	—	1,685	—	1,205	—	860	—
		6 3/8	6 1/8	—	—	—	—	—	—	1,345	—	860	—
	3	5 1/2	6 1/8	5 1/2	6 1/8	2,840	1,875	1,840	1,195	1,260	955	935	610
		7 1/4	6 1/8	—	—	—	—	—	—	1,465	—	935	—
	6	8 1/2	14 3/8	8 1/2	7	5,770	3,755	3,680	2,395	1,230	1,890	785	1,220
		14 1/2	9 3/4	—	—	—	—	—	—	1,825	—	1,160	—
8	10 1/2	19 7/8	10 1/2	8 1/2	7,695	5,010	4,905	3,190	1,185	2,400	755	1,625	
	19 1/4	13	—	—	—	—	—	—	1,825	—	1,160	—	
10	12 1/2	25 1/4	12 1/2	9 3/4	9,615	6,260	6,130	3,990	1,165	2,850	740	2,025	
	24	16 1/8	—	—	—	—	—	—	1,825	—	1,160	—	
5/8	3 1/8	6 1/4	7 7/8	6 1/4	7 3/8	3,015	2,135	2,260	1,395	1,525	1,040	1,145	665
		7 1/2	7 7/8	—	—	—	—	—	—	1,685	—	1,215	—
	5	8 1/8	10 1/2	8 1/8	7 7/8	6,105	3,700	4,135	2,360	2,075	1,740	1,445	1,110
		12	7 7/8	—	—	—	—	—	—	2,865	—	1,940	—
	7 1/2	10 5/8	18 3/8	10 5/8	9 1/8	9,725	5,555	6,200	3,540	1,945	2,595	1,240	1,665
		18	12 3/8	—	—	—	—	—	—	2,890	—	1,840	—
12 1/2	15 5/8	32 5/8	15 5/8	12 1/2	16,205	9,260	10,330	5,905	1,825	3,935	1,165	2,770	
	30	20 7/8	—	—	—	—	—	—	2,865	—	1,825	—	
3/4	3 1/2	7 1/4	9 3/8	7 1/4	8 7/8	3,575	2,535	2,680	1,640	1,875	1,185	1,405	755
		8 1/2	9 3/8	—	—	—	—	—	—	1,910	—	1,430	—
	6	9 3/4	12 3/8	9 3/4	9 3/8	8,025	5,165	6,020	3,295	2,700	2,310	2,025	1,475
		14 1/2	9 3/8	—	—	—	—	—	—	3,635	—	2,725	—
	9	12 3/4	21 1/4	12 3/4	11 1/4	14,450	7,755	9,210	4,945	2,900	3,425	1,850	2,210
		21 5/8	14 3/8	—	—	—	—	—	—	4,310	—	2,750	—
15	18 3/4	39 3/8	18 3/4	15 3/4	24,085	12,925	15,355	8,245	2,595	5,360	1,650	3,685	
	36	25 1/4	—	—	—	—	—	—	4,060	—	2,590	—	
7/8	3 3/4	8 1/8	11 1/8	8 1/8	10 1/2	3,965	2,805	2,975	1,280	2,060	1,280	1,330	565
		9	11 1/8	—	—	—	—	—	—	2,060	—	1,330	—
	7	11 3/8	13 3/4	11 3/8	11 1/8	10,110	6,040	5,735	2,670	3,390	2,615	2,000	1,160
		16 3/8	11 1/8	—	—	—	—	—	—	4,425	—	2,485	—
	10 1/2	14 7/8	24	14 7/8	12 1/2	18,580	9,060	8,605	4,010	3,880	3,925	1,715	1,735
		25 1/4	16 1/4	—	—	—	—	—	—	5,760	—	2,550	—
17 1/2	21 7/8	46	21 7/8	17 1/2	32,410	15,095	14,345	6,680	3,375	6,190	1,495	2,890	
	42	29 3/8	—	—	—	—	—	—	5,290	—	2,340	—	
1	4	9	12 3/8	9	12 3/8	4,370	3,095	3,275	2,020	2,225	1,345	1,665	860
		9 3/8	12 3/8	—	—	—	—	—	—	2,225	—	1,665	—
	8	13	15 3/8	13	12 3/8	12,355	6,335	8,355	4,040	4,140	2,690	2,850	1,715
		19 1/4	12 3/8	—	—	—	—	—	—	5,265	—	3,545	—
	12	17	26 3/4	17	12 3/4	19,655	9,500	12,530	6,055	3,835	4,030	2,445	2,570
		28 7/8	18	—	—	—	—	—	—	5,695	—	3,630	—
20	25	51 3/8	25	18 1/4	32,755	15,835	20,880	10,095	3,325	6,555	2,120	4,285	
	48	32 3/4	—	—	—	—	—	—	5,210	—	3,320	—	
1 1/4	5	11 1/4	13 3/8	11 1/4	13 3/8	6,105	4,325	4,350	2,435	—	—	—	—
		12	13 3/8	—	—	—	—	—	—	—	—	—	—
	10	16 1/4	18 1/4	16 1/4	13 3/8	15,465	8,660	8,700	4,870	—	—	—	—
		24	15	—	—	—	—	—	—	—	—	—	—
	15	21 1/4	32	21 1/4	15 3/4	23,195	12,990	13,050	7,305	—	—	—	—
		36	22 1/2	—	—	—	—	—	—	—	—	—	—
25	31 1/4	57 3/8	31 1/4	22	38,660	21,650	21,745	12,175	—	—	—	—	
	60	37 1/2	—	—	—	—	—	—	—	—	—	—	

Threaded Rod Dia. (in.)	Allowable Tension Load of Threaded Rod Steel (lb.)					
	ASTM F1554 GR 36	ASTM F1554 GR 55	ASTM F1554 GR 105	ASTM A193 B6	ASTM A193 B7	ASTM A193 B8/B8M
3/8	2,360	3,050	5,090	4,475	5,090	2,315
1/2	4,325	5,595	9,320	8,200	9,320	4,250
5/8	6,885	8,900	14,835	13,050	14,835	6,760
3/4	10,170	13,155	21,920	19,290	21,920	9,995
7/8	14,065	18,195	30,320	26,680	30,320	13,825
1	18,455	23,865	39,770	34,995	39,770	18,135
1 1/4	29,505	38,155	63,590	55,960	63,590	29,000

- Allowable tension load must be the lesser of the concrete, bond or threaded rod steel load.
- Allowable tension loads are calculated based on the strength design provisions of ACI 318-11 Appendix D assuming dry concrete, periodic inspection, short-term temperature of 180°F and long-term temperature of 110°F. Tension design strengths are converted to allowable tension loads using a conversion factor of $\alpha = 1/1.43$. The conversion factor α is based on the load combination assuming 100% seismic load.
- Tabulated values are for a single anchor with no influence of another anchor.
- Interpolation between embedment depths is not permitted.
- The allowable tension load listed for SDC (Seismic Design Category) A-B may also be used in SDC C-F when the tension component of the strength-level seismic design load on the anchor does not exceed 20% of the total factored tension load on the anchor associated with the same load combination.
- When designing anchorages in SDC C-F, the Designer shall consider the ductility requirements of ACI 318-11 Section D.3.3. Design strengths in **Bold** indicate that the anchor ductility requirements of D.3.3.4.3 (a)1 to 3 are satisfied when using ASTM F1554 Grade 36 threaded rod. Any other ductility requirements must be satisfied.
- Allowable tension loads in SDC C-F have been adjusted by 0.75 factor in accordance with ACI 318-11 Section D.3.3.4.4.

* See page 12 for an explanation of the load table icons.

AT-XP® Design Information — Concrete

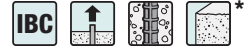

AT-XP® Tension Design Strengths for Rebar in Normal-Weight Concrete ($f'_c = 2,500$ psi)

Rebar Size	Nominal Embed. Depth (in.)	Minimum Dimensions for Uncracked (in.)		Minimum Dimensions for Cracked (in.)		Tension Design Strength Based on Concrete or Bond (lb.)							
		h_a	c_{ac}	h_a	c_{ac}	Edge Distances = c_{ac} on all sides				Edge Distances = $1\frac{3}{4}$ " on one side and c_{ac} on three sides			
						SDC A-B ⁶		SDC C-F ^{7,8}		SDC A-B ⁶		SDC C-F ^{7,8}	
		Uncracked	Cracked	Uncracked	Cracked	Uncracked	Cracked	Uncracked	Cracked				
#3	2¾	4¼	4¼	—	—	1,555	—	1,165	—	845	—	635	—
		5¾	3¾	—	—	—	—	—	—	980	—	735	—
	3	4⅞	5⅝	4⅞	3⅝	1,965	660	1,470	495	795	415	600	310
		7¼	4½	—	—	—	—	—	—	1,100	—	825	—
	4½	6⅞	9	6⅞	3⅝	2,945	990	2,210	745	740	625	555	470
		10⅞	6¾	—	—	—	—	—	—	1,100	—	825	—
6	7⅞	12½	7⅞	3⅝	3,925	1,320	2,945	990	715	830	540	625	
	14½	9	—	—	—	—	—	—	1,100	—	825	—	
7½	9⅞	15⅞	9⅞	3⅝	4,910	1,650	3,680	1,240	705	1,040	525	780	
	18	11¼	—	—	—	—	—	—	1,100	—	825	—	
#4	2¾	5¼	4¾	—	—	2,350	—	1,765	—	1,305	—	980	—
		6⅞	4¾	—	—	—	—	—	—	1,305	—	980	—
	3	5½	5⅝	5½	4¾	2,565	1,995	1,925	1,495	1,320	1,105	990	830
		7¼	4¾	—	—	—	—	—	—	1,425	—	1,070	—
	6	8½	11⅞	8½	5⅝	5,130	3,990	3,850	2,995	1,140	2,085	855	1,565
		14½	9	—	—	—	—	—	—	1,690	—	1,265	—
8	10½	16½	10½	6⅞	6,840	5,320	5,130	3,990	1,100	2,640	825	1,980	
	19¼	12	—	—	—	—	—	—	1,690	—	1,265	—	
10	12½	21	12½	8	8,555	6,650	6,415	4,990	1,080	3,175	810	2,380	
	24	15	—	—	—	—	—	—	1,690	—	1,265	—	
#5	3¾	6¼	5⅞	6¼	5⅝	3,275	2,630	2,455	1,975	1,675	1,350	1,260	1,010
		7½	5⅝	—	—	—	—	—	—	1,675	—	1,260	—
	5	8⅞	9¼	8⅞	5⅝	5,240	4,210	3,930	3,160	1,725	2,160	1,295	1,620
		12	7½	—	—	—	—	—	—	2,385	—	1,785	—
	7½	10⅞	14¼	10⅞	7⅝	7,855	6,320	5,890	4,740	1,605	2,995	1,205	2,245
18		11¼	—	—	—	—	—	—	2,385	—	1,785	—	
#6	3½	7¼	7	7¼	7	4,330	3,585	3,250	2,685	2,100	1,735	1,575	1,300
		8½	7	—	—	—	—	—	—	2,100	—	1,575	—
	6	9¾	11	9¾	7½	7,425	6,145	5,570	4,605	2,310	2,935	1,730	2,200
		14½	9	—	—	—	—	—	—	3,190	—	2,395	—
9	12¾	17⅞	12¾	9⅞	11,140	9,215	8,355	6,910	2,150	4,135	1,610	3,105	
	21⅞	13½	—	—	—	—	—	—	3,190	—	2,395	—	
15	18¾	31	18¾	13⅞	18,565	15,355	13,925	11,515	2,035	6,455	1,525	4,845	
	36	22½	—	—	—	—	—	—	3,190	—	2,395	—	
#7	3¾	8⅞	8⅞	8⅞	7¾	5,300	4,010	3,975	3,010	2,470	1,950	1,850	1,465
		9	8⅞	—	—	—	—	—	—	2,470	—	1,850	—
	7	11⅞	12⅝	11⅞	9¼	9,895	8,415	7,420	6,310	2,950	3,805	2,210	2,855
		16⅞	10½	—	—	—	—	—	—	4,075	—	3,055	—
	10½	14⅞	20⅞	14⅞	12⅞	14,845	12,620	11,130	9,465	2,745	5,400	2,060	4,050
25¼		15¾	—	—	—	—	—	—	4,075	—	3,055	—	
17½	21⅞	35¾	21⅞	17	24,740	21,035	18,555	15,775	2,600	8,495	1,950	6,370	
	42	26¼	—	—	—	—	—	—	4,075	—	3,055	—	
#8	4	9	9⅞	9	9⅞	5,175	4,420	3,880	3,315	2,335	2,030	1,750	1,520
		9⅞	9⅞	—	—	—	—	—	—	2,335	—	1,750	—
	8	13	14⅞	13	9¾	10,350	8,990	7,760	6,745	2,985	4,060	2,240	3,045
		19¼	12	—	—	—	—	—	—	4,125	—	3,095	—
	12	17	23⅞	17	12⅝	15,525	13,485	11,640	10,115	2,780	5,695	2,085	4,270
28⅞		18	—	—	—	—	—	—	4,125	—	3,095	—	
20	25	40½	25	17¾	25,870	22,480	19,405	16,860	2,630	9,015	1,975	6,760	
	48	30	—	—	—	—	—	—	4,125	—	3,095	—	
#10	5	11¼	11¼	11¼	10½	7,730	6,175	5,800	4,635	—	—	—	—
		12	11¼	—	—	—	—	—	—	—	—	—	—
	10	16¼	17⅝	16¼	13¼	15,465	14,490	11,595	10,870	—	—	—	—
		24	15	—	—	—	—	—	—	—	—	—	—
15	21¼	28⅞	21¼	17⅝	23,195	21,735	17,395	16,300	—	—	—	—	
	36	22½	—	—	—	—	—	—	—	—	—	—	
25	31¼	49¾	31¼	24½	38,655	36,225	28,990	27,170	—	—	—	—	
	60	37½	—	—	—	—	—	—	—	—	—	—	

Adhesive Anchors

C-A-2016 © 2015 SIMPSON STRONG-TIE COMPANY INC.

Rebar Size	Tension Design Strength of Rebar Steel (lb.)	
	ASTM A615 GR 60	ASTM A706 GR 60
#3	6,435	5,720
#4	11,700	10,400
#5	18,135	16,120
#6	25,740	22,880
#7	35,100	31,200
#8	46,215	41,080
#10	74,100	66,040

1. Tension design strength must be the lesser of the concrete, bond or rebar steel design strength.
2. Tension design strengths are based on the strength design provisions of ACI 318-11 Appendix D assuming dry concrete, periodic inspection, short-term temperature of 180°F and long-term temperature of 110°F.
3. Tabulated values are for a single anchor with no influence of another anchor.
4. Interpolation between embedment depths is not permitted.
5. Strength reduction factor, ϕ , is based on using a load combination from ACI 318-11 Section 9.2.
6. The tension design strength listed for SDC (Seismic Design Category) A-B may also be used in SDC C-F when the tension component of the strength-level seismic design load on the anchor does not exceed 20% of the total factored tension load on the anchor associated with the same load combination.
7. When designing anchorages in SDC C-F, the Designer shall consider the ductility requirements of ACI 318-11 Section D.3.3.
8. Tension design strengths in SDC C-F have been adjusted by 0.75 factor in accordance with ACI 318-11 Section D.3.3.4.4.

* See page 12 for an explanation of the load table icons.

AT-XP® Design Information — Concrete

AT-XP® Allowable Tension Loads for Rebar in Normal-Weight Concrete
(f'c = 2,500 psi) — Static Load

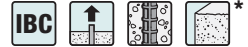

Adhesive Anchors

Rebar Size	Nominal Embed. Depth (in.)	Minimum Dimensions for Uncracked (in.)		Minimum Dimensions for Cracked (in.)		Allowable Tension Load Based on Concrete or Bond (lb.)			
		h _a	c _{ac}	h _a	c _{ac}	Edge Distances = c _{ac} on all sides		Edge Distances = 1 3/4" on one side and c _{ac} on three sides	
						Uncracked	Cracked	Uncracked	Cracked
#3	2 3/8	4 1/4	4 1/4	—	—	1,110	—	605	—
		5 3/4	3 3/8	—	—			700	—
	3	4 7/8	5 5/8	4 7/8	3 3/8	1,405	470	570	295
		7 1/4	4 1/2	—	—			785	
	4 1/2	6 3/8	9	6 3/8	3 3/8	2,105	705	530	445
10 7/8		6 3/4	—	—	785			—	
6	7 7/8	12 1/2	7 7/8	3 3/8	2,805	945	510	595	
	14 1/2	9	—	—			785		—
7 1/2	9 3/8	15 7/8	9 3/8	3 3/8	3,505	1,180	505	745	
	18	11 1/4	—	—			785		—
#4	2 3/4	5 1/4	4 3/4	—	—	1,680	—	930	—
		6 5/8	4 3/4	—	—			930	—
	3	5 1/2	5 1/8	5 1/2	4 3/4	1,830	1,425	945	790
		7 1/4	4 3/4	—	—			1,020	
	6	8 1/2	11 7/8	8 1/2	5 3/8	3,665	2,850	815	1,490
		14 1/2	9	—	—			1,205	
8	10 1/2	16 1/2	10 1/2	6 7/8	4,885	3,800	785	1,885	
	19 1/4	12	—	—			1,205		—
10	12 1/2	21	12 1/2	8	6,110	4,750	770	2,270	
	24	15	—	—			1,205		—
#5	3 3/8	6 1/4	5 7/8	6 1/4	5 7/8	2,340	1,880	1,195	965
		7 1/2	5 7/8	—	—			1,195	
	5	8 1/8	9 1/4	8 1/8	5 7/8	3,745	3,005	1,230	1,545
		12	7 1/2	—	—			1,705	
7 1/2	10 3/8	14 3/4	10 3/8	7 3/8	5,610	4,515	1,145	2,140	
	18	11 1/4	—	—			1,705		—
12 1/2	15 5/8	26	15 5/8	10 3/4	9,355	7,520	1,085	3,295	
	30	18 3/4	—	—			1,705		—
#6	3 1/2	7 1/4	7	7 1/4	7	3,095	2,560	1,500	1,240
		8 1/2	7	—	—			1,500	
	6	9 3/4	11	9 3/4	7 1/2	5,305	4,390	1,650	2,095
		14 1/2	9	—	—			2,280	
	9	12 3/4	17 3/8	12 3/4	9 7/8	7,955	6,580	1,535	2,955
21 5/8		13 1/2	—	—	2,280			—	
15	18 3/4	31	18 3/4	13 3/8	13,260	10,970	1,455	4,610	
	36	22 1/2	—	—			2,280		—
#7	3 3/4	8 1/8	8 1/8	8 1/8	7 3/4	3,785	2,865	1,765	1,395
		9	8 1/8	—	—			1,765	
	7	11 3/8	12 5/8	11 3/8	9 1/4	7,070	6,010	2,105	2,720
		16 7/8	10 1/2	—	—			2,910	
	10 1/2	14 7/8	20 3/8	14 7/8	12 1/8	10,605	9,015	1,960	3,855
25 1/4		15 3/4	—	—	2,910			—	
17 1/2	21 7/8	35 3/4	21 7/8	17	17,670	15,025	1,855	6,070	
	42	26 1/4	—	—			2,910		—
#8	4	9	9 1/8	9	9 1/8	3,695	3,155	1,670	1,450
		9 5/8	9 1/8	—	—			1,670	
	8	13	14 3/8	13	9 3/4	7,395	6,420	2,130	2,900
		19 1/4	12	—	—			2,945	
	12	17	23 1/8	17	12 5/8	11,090	9,630	1,985	4,070
28 7/8		18	—	—	2,945			—	
20	25	40 1/2	25	17 3/4	18,480	16,055	1,880	6,440	
	48	30	—	—			2,945		—
#10	5	11 1/4	11 1/4	11 1/4	10 1/2	5,520	4,410	—	—
		12	11 1/4	—	—			—	—
	10	16 1/4	17 5/8	16 1/4	13 1/4	11,045	10,350	—	—
		24	15	—	—			—	—
	15	21 1/4	28 3/8	21 1/4	17 3/8	16,570	15,525	—	—
		36	22 1/2	—	—			—	—
	25	31 1/4	49 3/4	31 1/4	24 1/2	27,610	25,875	—	—
		60	37 1/2	—	—			—	—

Rebar Size	Allowable Tension Load of Rebar Steel (lb.)	
	ASTM A615 GR 60	ASTM A706 GR 60
#3	4,595	4,085
#4	8,355	7,430
#5	12,955	11,515
#6	18,385	16,345
#7	25,070	22,285
#8	33,010	29,345
#10	52,930	47,170

1. Allowable tension load must be the lesser of the concrete, bond or rebar steel load.
2. Allowable tension loads are calculated based on the strength design provisions of ACI 318-11 Appendix D assuming dry concrete, periodic inspection, short-term temperature of 180°F and long-term temperature of 110°F. Tension design strengths are converted to allowable tension loads using a conversion factor of $\alpha = 1.4$. The conversion factor α is based on the load combination 1.2D + 1.6L assuming 50% dead load and 50% live load: $1.2(0.5) + 1.6(0.5) = 1.4$.
3. Tabulated values are for a single anchor with no influence of another anchor.
4. Interpolation between embedment depths is not permitted.

* See page 12 for an explanation of the load table icons.

AT-XP® Design Information — Concrete

AT-XP® Allowable Tension Loads for Rebar in Normal-Weight Concrete
(f_c = 2,500 psi) — Wind Load

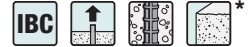

Rebar Size	Nominal Embed. Depth (in.)	Minimum Dimensions for Uncracked (in.)		Minimum Dimensions for Cracked (in.)		Allowable Tension Load Based on Concrete or Bond (lb.)			
		h _a	c _{ac}	h _a	c _{ac}	Edge Distances = c _{ac} on all sides		Edge Distances = 1 3/4" on one side and c _{ac} on three sides	
						Uncracked	Cracked	Uncracked	Cracked
#3	2 3/8	4 1/4	4 1/4	—	—	935	—	505	—
		5 3/4	3 3/8	—	—			590	
	3	4 7/8	5 5/8	4 7/8	3 3/8	1,180	395	475	250
		7 1/4	4 1/2	—	—			660	
	4 1/2	6 3/8	9	6 3/8	3 3/8	1,765	595	445	375
10 7/8		6 3/4	—	—	660				
6	7 7/8	12 1/2	7 7/8	3 3/8	2,355	790	430	500	
	14 1/2	9	—	—			660		
	9 3/8	15 7/8	9 3/8	3 3/8			425		
#4	2 3/4	5 1/4	4 3/4	—	—	1,410	—	785	—
		6 5/8	4 3/4	—	—			785	
	3	5 1/2	5 1/8	5 1/2	4 3/4	1,540	1,195	790	665
		7 1/4	4 3/4	—	—			855	
	6	8 1/2	11 7/8	8 1/2	5 3/8	3,080	2,395	685	1,250
14 1/2		9	—	—	1,015				
8	10 1/2	16 1/2	10 1/2	6 7/8	4,105	3,190	660	1,585	
	19 1/4	12	—	—			1,015		
10	12 1/2	21	12 1/2	8	5,135	3,990	650	1,905	
	24	15	—	—			1,015		
#5	3 3/8	6 1/4	5 7/8	6 1/4	5 7/8	1,965	1,580	1,005	810
		7 1/2	5 7/8	—	—			1,005	
	5	8 1/8	9 1/4	8 1/8	5 7/8	3,145	2,525	1,035	1,295
		12	7 1/2	—	—			1,430	
	7 1/2	10 5/8	14 3/4	10 5/8	7 3/8	4,715	3,790	965	1,795
18		11 1/4	—	—	1,430				
12 1/2	15 5/8	26	15 5/8	10 3/4	7,855	6,320	910	2,770	
	30	18 3/4	—	—			1,430		
#6	3 1/2	7 1/4	7	7 1/4	7	2,600	2,150	1,260	1,040
		8 1/2	7	—	—			1,260	
	6	9 3/4	11	9 3/4	7 1/2	4,455	3,685	1,385	1,760
		14 1/2	9	—	—			1,915	
	9	12 3/4	17 3/8	12 3/4	9 3/8	6,685	5,530	1,290	2,480
21 3/8		13 1/2	—	—	1,915				
15	18 3/4	31	18 3/4	13 3/8	11,140	9,215	1,220	3,875	
	36	22 1/2	—	—			1,915		
#7	3 3/4	8 1/8	8 1/8	8 1/8	7 3/4	3,180	2,405	1,480	1,170
		9	8 1/8	—	—			1,480	
	7	11 3/8	12 3/8	11 3/8	9 1/4	5,935	5,050	1,770	2,285
		16 7/8	10 1/2	—	—			2,445	
	10 1/2	14 7/8	20 3/8	14 7/8	12 1/8	8,905	7,570	1,645	3,240
25 1/4		15 3/4	—	—	2,445				
17 1/2	21 7/8	35 3/4	21 7/8	17	14,845	12,620	1,560	5,095	
	42	26 1/4	—	—			2,445		
#8	4	9	9 1/8	9	9 1/8	3,105	2,650	1,400	1,220
		9 5/8	9 1/8	—	—			1,400	
	8	13	14 3/8	13	9 3/4	6,210	5,395	1,790	2,435
		19 1/4	12	—	—			2,475	
	12	17	23 1/8	17	12 5/8	9,315	8,090	1,670	3,415
28 7/8		18	—	—	2,475				
20	25	40 1/2	25	17 3/4	15,520	13,490	1,580	5,410	
	48	30	—	—			2,475		
#10	5	11 1/4	11 1/4	11 1/4	10 1/2	4,640	3,705	—	—
		12	11 1/4	—	—			—	
	10	16 1/4	17 5/8	16 1/4	13 1/4	9,280	8,695	—	—
		24	15	—	—			—	
	15	21 1/4	28 3/8	21 1/4	17 3/8	13,915	13,040	—	—
36		22 1/2	—	—	—				
25	31 1/4	49 3/4	31 1/4	24 1/2	23,195	21,735	—	—	
	60	37 1/2	—	—			—		

Adhesive Anchors

C-A-2016 © 2015 SIMPSON STRONG-TIE COMPANY INC.

Rebar Size	Allowable Tension Load of Rebar Steel (lb.)	
	ASTM A615 GR 60	ASTM A706 GR 60
#3	3,860	3,430
#4	7,020	6,240
#5	10,880	9,670
#6	15,445	13,730
#7	21,060	18,720
#8	27,730	24,650
#10	44,460	39,625

1. Allowable tension load must be the lesser of the concrete, bond or rebar steel load.
2. Allowable tension loads are calculated based on the strength design provisions of ACI 318-11 Appendix D assuming dry concrete, periodic inspection, short-term temperature of 180°F and long-term temperature of 110°F. Tension design strengths are converted to allowable tension loads using a conversion factor of $\alpha = 1/1.67$. The conversion factor α is based on the load combination assuming 100% wind load.
3. Tabulated values are for a single anchor with no influence of another anchor.
4. Interpolation between embedment depths is not permitted.

* See page 12 for an explanation of the load table icons.

AT-XP® Design Information — Concrete

AT-XP® Allowable Tension Loads for Rebar in Normal-Weight Concrete
(f'c = 2,500 psi) — Seismic Load

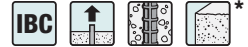

Adhesive Anchors

Rebar Size	Nominal Embed. Depth (in.)	Minimum Dimensions for Uncracked (in.)		Minimum Dimensions for Cracked (in.)		Allowable Tension Load Based on Concrete or Bond (lb.)							
						Edge Distances = c _{ac} on all sides				Edge Distances = 1¾" on one side and c _{ac} on three sides			
						SDC A-B ⁵		SDC C-F ^{6,7}		SDC A-B ⁵		SDC C-F ^{6,7}	
						Uncracked	Cracked	Uncracked	Cracked	Uncracked	Cracked	Uncracked	Cracked
#3	2½	4¼	4¼	—	—	1,090	—	815	—	590	—	445	—
		5¼	3¾	—	—	—	—	—	—	685	—	515	—
	3	4¾	5½	4⅞	3⅝	1,375	460	1,030	345	555	290	420	215
		7¼	4½	—	—	—	—	—	—	770	—	580	—
	4½	6¾	9	6¾	3¾	2,060	695	1,545	520	520	440	390	330
		10⅞	6¾	—	—	—	—	—	—	770	—	580	—
6	7⅞	12½	7⅞	3¾	2,750	925	2,060	695	500	580	380	440	
	14½	9	—	—	—	—	—	—	770	—	580	—	
7½	9¾	15⅞	9¾	3¾	3,435	1,155	2,575	870	495	730	370	545	
	18	11¼	—	—	—	—	—	—	770	—	580	—	
#4	2¾	5¼	4¾	—	—	1,645	—	1,235	—	915	—	685	—
		6¾	4¾	—	—	—	—	—	—	915	—	685	—
	3	5½	5½	5½	4¾	1,795	1,395	1,350	1,045	925	775	695	580
		7¼	4¾	—	—	—	—	—	—	1,000	—	750	—
	6	8½	11⅞	8½	5½	3,590	2,795	2,695	2,095	800	1,460	600	1,095
		14½	9	—	—	—	—	—	—	1,185	—	885	—
8	10½	16½	10½	6⅞	4,790	3,725	3,590	2,795	770	1,850	580	1,385	
	19¼	12	—	—	—	—	—	—	1,185	—	885	—	
10	12½	21	12½	8	5,990	4,655	4,490	3,495	755	2,225	565	1,665	
	24	15	—	—	—	—	—	—	1,185	—	885	—	
#5	3¾	6¼	5⅞	6¼	5⅞	2,295	1,840	1,720	1,385	1,175	945	880	705
		7½	5⅞	—	—	—	—	—	—	1,175	—	880	—
	5	8½	9¼	8½	5⅞	3,670	2,945	2,750	2,210	1,210	1,510	905	1,135
		12	7½	—	—	—	—	—	—	1,670	—	1,250	—
	7½	10⅞	14¾	10⅞	7¾	5,500	4,425	4,125	3,320	1,125	2,095	845	1,570
		18	11¼	—	—	—	—	—	—	1,670	—	1,250	—
12½	15⅞	26	15⅞	10¾	9,165	7,370	6,875	5,525	1,065	3,230	800	2,420	
	30	18¾	—	—	—	—	—	—	1,670	—	1,250	—	
#6	3½	7¼	7	7¼	7	3,030	2,510	2,275	1,880	1,470	1,215	1,105	910
		8½	7	—	—	—	—	—	—	1,470	—	1,105	—
	6	9¾	11	9¾	7½	5,200	4,300	3,900	3,225	1,615	2,055	1,210	1,540
		14½	9	—	—	—	—	—	—	2,235	—	1,675	—
	9	12¾	17⅞	12¾	9⅞	7,800	6,450	5,850	4,835	1,505	2,895	1,125	2,175
		21⅞	13½	—	—	—	—	—	—	2,235	—	1,675	—
15	18¾	31	18¾	13⅞	12,995	10,750	9,750	8,060	1,425	4,520	1,070	3,390	
	36	22½	—	—	—	—	—	—	2,235	—	1,675	—	
#7	3¾	8½	8½	8½	7¾	3,710	2,805	2,785	2,105	1,730	1,365	1,295	1,025
		9	8½	—	—	—	—	—	—	1,730	—	1,295	—
	7	11⅞	12⅞	11⅞	9¼	6,925	5,890	5,195	4,415	2,065	2,665	1,545	2,000
		16⅞	10½	—	—	—	—	—	—	2,855	—	2,140	—
	10½	14⅞	20⅞	14⅞	12½	10,390	8,835	7,790	6,625	1,920	3,780	1,440	2,835
		25¼	15¾	—	—	—	—	—	—	2,855	—	2,140	—
17½	21⅞	35¾	21⅞	17	17,320	14,725	12,990	11,045	1,820	5,945	1,365	4,460	
	42	26¼	—	—	—	—	—	—	2,855	—	2,140	—	
#8	4	9	9⅞	9	9⅞	3,625	3,095	2,715	2,320	1,635	1,420	1,225	1,065
		9⅞	9⅞	—	—	—	—	—	—	1,635	—	1,225	—
	8	13	14⅞	13	9¾	7,245	6,295	5,430	4,720	2,090	2,840	1,570	2,130
		19¼	12	—	—	—	—	—	—	2,890	—	2,165	—
	12	17	23⅞	17	12⅞	10,870	9,440	8,150	7,080	1,945	3,985	1,460	2,990
		28⅞	18	—	—	—	—	—	—	2,890	—	2,165	—
20	25	40½	25	17¾	18,110	15,735	13,585	11,800	1,840	6,310	1,385	4,730	
	48	30	—	—	—	—	—	—	2,890	—	2,165	—	
#10	5	11¼	11¼	11¼	10½	5,410	4,325	4,060	3,245	—	—	—	—
		12	11¼	—	—	—	—	—	—	—	—	—	—
	10	16¼	17⅞	16¼	13¼	10,825	10,145	8,115	7,610	—	—	—	—
		24	15	—	—	—	—	—	—	—	—	—	—
15	21¼	28⅞	21¼	17⅞	16,235	15,215	12,175	11,410	—	—	—	—	
	36	22½	—	—	—	—	—	—	—	—	—	—	
25	31¼	49¾	31¼	24½	27,060	25,360	20,295	19,020	—	—	—	—	
	60	37½	—	—	—	—	—	—	—	—	—	—	

Rebar Size	Allowable Tension Load of Rebar Steel (lb.)	
	ASTM A615 GR 60	ASTM A706 GR 60
#3	4,505	4,005
#4	8,190	7,280
#5	12,695	11,285
#6	18,020	16,015
#7	24,570	21,840
#8	32,350	28,755
#10	51,870	46,230

1. Allowable tension load must be the lesser of the concrete, bond or rebar steel load.
2. Allowable tension loads are calculated based on the strength design provisions of ACI 318-11 Appendix D assuming dry concrete, periodic inspection, short-term temperature of 180°F and long-term temperature of 110°F. Tension design strengths are converted to allowable tension loads using a conversion factor of $\alpha = 1/1.43 = 0.7$. The conversion factor α is based on the load combination assuming 100% seismic load.
3. Tabulated values are for a single anchor with no influence of another anchor.
4. Interpolation between embedment depths is not permitted.
5. The allowable tension load listed for SDC (Seismic Design Category) A-B may also be used in SDC C-F when the tension component of the strength-level seismic design load on the anchor does not exceed 20% of the total factored tension load on the anchor associated with the same load combination.
6. When designing anchorages in SDC C-F, the Designer shall consider the ductility requirements of ACI 318-11 Section D.3.3.
7. Allowable tension loads in SDC C-F have been adjusted by 0.75 factor in accordance with ACI 318-11 Section D.3.3.4.4.

* See page 12 for an explanation of the load table icons.

AT-XP® Design Information — Masonry

AT-XP® Allowable Tension and Shear Loads for Threaded Rod and Rebar in the Face of Fully Grouted CMU Wall Construction ^{1, 3, 4, 5, 6, 8, 9, 10, 11}

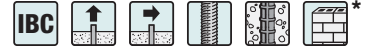

Diameter (in.) or Rebar Size No.	Drill Bit Diameter (in.)	Minimum Embedment ² (in.)	Allowable Load Based on Bond Strength ⁷ (lb.)	
			Tension Load	Shear Load
Threaded Rod Installed in the Face of CMU Wall				
3/8	1/2	3 3/8	1,265	1,135
1/2	5/8	4 1/2	1,910	1,660
5/8	3/4	5 5/8	2,215	1,810
3/4	7/8	6 1/2	2,260	1,810
Rebar Installed in the Face of CMU Wall				
#3	1/2	3 3/8	1,180	1,315
#4	5/8	4 1/2	1,720	1,565
#5	3/4	5 5/8	1,835	1,565

- Allowable load shall be the lesser of the bond values shown in this table and steel values, shown on page 37.
- Embedment depth shall be measured from the outside face of masonry wall.
- Critical and minimum edge distance and spacing shall comply with the information on page 36. Figure 2 on page 36 illustrates critical and minimum edge and end distances.
- Minimum allowable nominal width of CMU wall shall be 8 inches. No more than one anchor shall be permitted per masonry cell.
- Anchors shall be permitted to be installed at any location in the face of the fully grouted masonry wall construction (cell, web, bed joint), except anchors shall not be installed within 1 1/2 inches of the head joint, as show in Figure 2 on page 36.
- Tabulated allowable load values are for anchors installed in fully grouted masonry walls.
- Tabulated allowable loads are based on a safety factor of 5.0.
- Tabulated allowable load values shall be adjusted for increased base material temperatures in accordance with Figure 1 below, as applicable.
- Threaded rod and rebar installed in fully grouted masonry walls are permitted to resist dead, live, seismic and wind loads.
- Threaded rod shall meet or exceed the tensile strength of ASTM F1554, Grade 36 steel, which is 58,000 psi.
- For installations exposed to severe, moderate or negligible exterior weathering conditions, as defined in Figure 1 of ASTM C62, allowable tension loads shall be multiplied by 0.80.

Adhesive Anchors

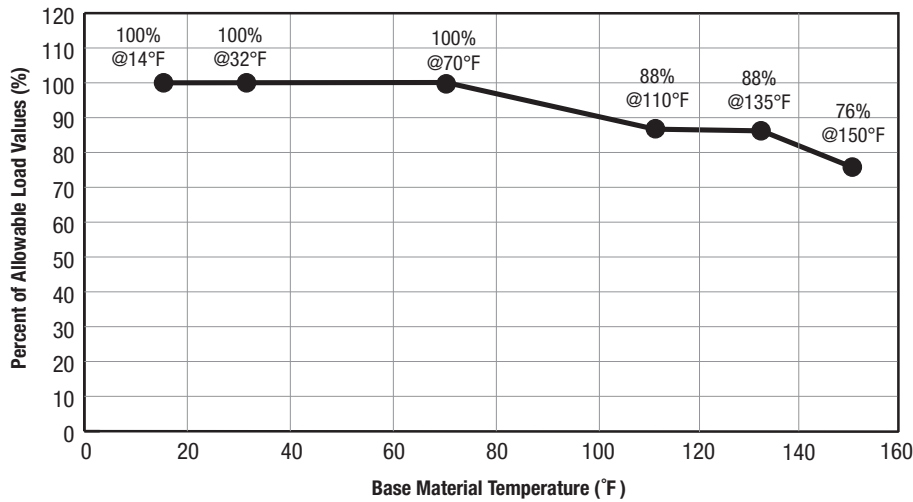
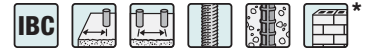

Figure 1. Load capacity based on in-service temperature for AT-XP® adhesive in the face of fully grouted CMU wall construction

* See page 12 for an explanation of the load table icons.

AT-XP® Design Information — Masonry

AT-XP® Edge Distance and Spacing Requirements and Allowable Load Reduction Factors — Threaded Rod and Rebar in the Face of Fully Grouted CMU Wall Construction⁷



Adhesive Anchors

Rod Dia. (in.) or Rebar Size No.	Minimum Embed. Depth (in.)	Edge or Edge Distance ^{1,8}						Spacing ^{2,9}				
		Critical (Full Anchor Capacity) ³		Minimum (Reduced Anchor Capacity) ⁴				Critical (Full Anchor Capacity) ⁵		Minimum (Reduced Anchor Capacity) ⁶		
		Critical Edge or End Distance, C_{cr} (in.)	Allowable Load Reduction Factor	Minimum Edge or End Distance, C_{min} (in.)	Allowable Load Reduction Factor			Critical Spacing, S_{cr} (in.)	Allowable Load Reduction Factor	Minimum Spacing, S_{min} (in.)	Allowable Load Reduction Factor	
		Load Direction		Load Direction				Load Direction		Load Direction		
		Tension or Shear	Tension or Shear	Tension or Shear	Tension	Shear ¹⁰		Tension or Shear	Tension or Shear	Tension or Shear	Tension	Shear
				Perp.	Para.							
¾	3¾	12	1.00	4	1.00	0.76	0.94	8	1.00	4	1.00	1.00
½	4½	12	1.00	4	0.90	0.57	0.94	8	1.00	4	1.00	1.00
¾	5¾	12	1.00	4	0.72	0.47	0.94	8	1.00	4	1.00	1.00
¾	6½	12	1.00	4	0.72	0.47	0.94	8	1.00	4	1.00	1.00
#3	3¾	12	1.00	4	1.00	0.62	0.95	8	1.00	4	1.00	1.00
#4	4½	12	1.00	4	1.00	0.37	0.82	8	1.00	4	1.00	0.89
#5	5¾	12	1.00	4	1.00	0.37	0.82	8	1.00	4	1.00	0.89

- Edge distance (C_{cr} or C_{min}) is the distance measured from anchor centerline to edge or end of CMU masonry wall. Refer to Figure 2 below for an illustration showing critical and minimum edge and end distances.
- Anchor spacing (S_{cr} or S_{min}) is the distance measured from centerline to centerline of two anchors.
- Critical edge distance, C_{cr} , is the least edge distance at which tabulated allowable load of an anchor is achieved where a load reduction factor equals 1.0 (no load reduction).
- Minimum edge distance, C_{min} , is the least edge distance where an anchor has an allowable load capacity which shall be determined by multiplying the allowable loads assigned to anchors installed at critical edge distance, C_{cr} , by the load reduction factors shown above.
- Critical spacing, S_{cr} , is the least anchor spacing at which tabulated allowable load of an anchor is achieved such that anchor performance is not influenced by adjacent anchors.

- Minimum spacing, S_{min} , is the least spacing where an anchors has an allowable load capacity, which shall be determined by multiplying the allowable loads assigned to anchors installed at critical spacing distance, S_{cr} , by the load reduction factors shown above.
- Reduction factors are cumulative. Multiple reduction factors for more than one spacing or edge or end distance shall be calculated separately and multiplied.
- Load reduction factor for anchors loaded in tension or shear with edge distances between critical and minimum shall be obtained by linear interpolation.
- Load reduction factor for anchors loaded in tension with spacing between critical and minimum shall be obtained by linear interpolation.
- Perpendicular shear loads act towards the edge or end. Parallel shear loads act parallel to the edge or end (see Figure 3 below). Perpendicular and parallel shear load reduction factors are cumulative when the anchor is located between the critical minimum edge and end distance.

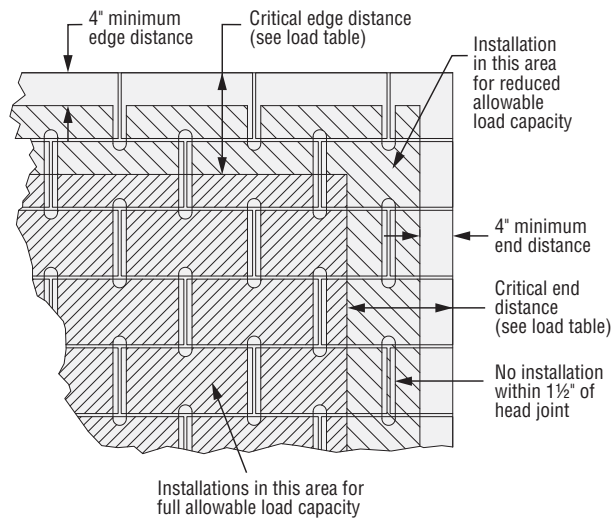

Figure 2. Allowable Anchor Locations for Full and Reduced Load Capacity When Installation Is in the Face of Fully Grouted CMU Masonry Wall Construction

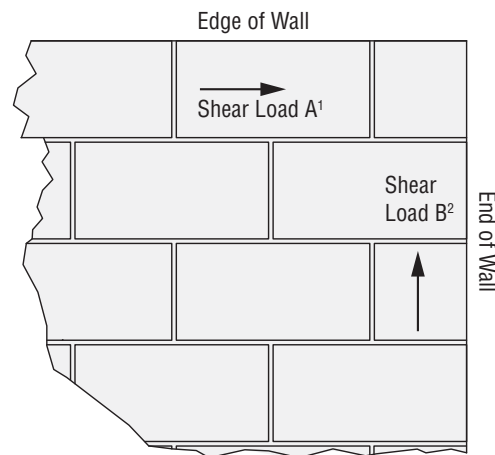

Figure 3. Direction of Shear Load in Relation to Edge and End of Wall

- Direction of Shear Load A is parallel to edge of wall and perpendicular to end of wall.
- Direction of Shear Load B is parallel to end of wall and perpendicular to edge of wall.

* See page 12 for an explanation of the load table icons.

AT-XP® Design Information — Masonry

AT-XP® Allowable Tension and Shear Loads —
Threaded Rod Based on Steel Strength¹

Threaded Rod Diameter (in.)	Tensile Stress Area (in. ²)	Tension Load Based on Steel Strength ² (lb.)				Shear Load Based on Steel Strength ³ (lb.)			
		ASTM F1554 Grade 36 ⁴	ASTM A193 Grade B7 ⁶	Stainless Steel		ASTM F1554 Grade 36 ⁴	ASTM A193 Grade B7 ⁶	Stainless Steel	
				ASTM A193 Grade B6 ⁵	ASTM A193 Grades B8 and B8M ⁷			ASTM A193 Grade B6 ⁵	ASTM A193 Grades B8 and B8M ⁷
3/8	0.078	1,495	3,220	2,830	1,930	770	1,660	1,460	995
1/2	0.142	2,720	5,860	5,155	3,515	1,400	3,020	2,655	1,810
5/8	0.226	4,325	9,325	8,205	5,595	2,230	4,805	4,225	2,880
3/4	0.334	6,395	13,780	12,125	8,265	3,295	7,100	6,245	4,260

1. Allowable load shall be the lesser of bond values given on page 35 and steel values in the table above.
2. Allowable Tension Steel Strength is based on the following equation: $F_v = 0.33 \times F_u \times \text{Tensile Stress Area}$.
3. Allowable Shear Steel Strength is based on the following equation: $F_v = 0.17 \times F_u \times \text{Tensile Stress Area}$.
4. Minimum specified tensile strength ($F_u = 58,000$ psi) of ASTM F1554, Grade 36 used to calculate allowable steel strength.

5. Minimum specified tensile strength ($F_u = 110,000$ psi) of ASTM A193, Grade B6 used to calculate allowable steel strength.
6. Minimum specified tensile strength ($F_u = 125,000$ psi) of ASTM A193, Grade B7 used to calculate allowable steel strength.
7. Minimum specified tensile strength ($F_u = 75,000$ psi) of ASTM A193, Grades B8 and B8M used to calculate allowable steel strength.

AT-XP® Allowable Tension and Shear Loads —
Deformed Reinforcing Bar Based on Steel Strength¹

Drill Bit Diameter (in.)	Minimum Embedment ² (in.)	Tension Load (lb.)		Shear Load (lb.)	
		Based on Steel Strength		Based on Steel Strength	
		ASTM A615 Grade 40 ²	ASTM A615 Grade 60 ³	ASTM A615 Grade 40 ^{4,5}	ASTM A615 Grade 60 ^{4,6}
#3	0.11	2,200	2,640	1,310	1,685
#4	0.20	4,000	4,800	2,380	3,060
#5	0.31	6,200	7,400	3,690	4,745

1. Allowable load shall be the lesser of bond values given on page 35 and steel values in the table above.
2. Allowable Tension Steel Strength is based on AC58 Section 3.3.3 (20,000 psi x tensile stress area) for Grade 40 rebar.
3. Allowable Tension Steel Strength is based on AC58 Section 3.3.3 (24,000 psi x tensile stress area) for Grade 60 rebar.

4. Allowable Shear Steel Strength is based on AC58 Section 3.3.3 ($F_v = 0.17 \times F_u \times \text{Tensile Stress Area}$).
5. $F_u = 70,000$ psi for Grade 40 rebar.
6. $F_u = 90,000$ psi for Grade 60 rebar.

* See page 12 for an explanation of the load table icons.

SET-XP® High-Strength Epoxy Adhesive

SET-XP® epoxy anchoring adhesive is a high-strength formula for anchoring and doweling in cracked and uncracked concrete and masonry applications. It is a two-part system with the resin and hardener being simultaneously dispensed and mixed through the mixing nozzle. When properly mixed, adhesive will be a uniform teal color for easy post-installation identification.

Features

- 1:1 two-component, high-solids, epoxy-based anchoring adhesive formula
- Passed the demanding ICC-ES AC308 adverse-condition tests pertaining to elevated temperatures and long-term sustained loads
- Code listed under the IBC/IRC for cracked and uncracked concrete per ICC-ES ESR-2508
- Code listed under the IBC/IRC for masonry per IAPMO UES ER-265
- Suitable for use under static and seismic loading conditions in cracked and uncracked concrete and masonry
- Cure times: 24 hours at 70°F, 72 hours at 50°F
- Easy hole-cleaning – no power-brushing required
- Suitable for use in dry or water-saturated concrete
- For best results, store between 45°F and 90°F
- Available in 8.5 oz., 22 oz. and 56 oz. cartridges for application versatility
- Manufactured in the USA using global materials

Applications

- Threaded rod anchoring and rebar doweling into concrete and masonry
- Suitable for horizontal, vertical and overhead applications
- Multiple DOT listings – refer to www.strongtie.com/DOT for current approvals

Codes: ICC-ES ESR-2508 (concrete); IAPMO UES ER-265 (masonry); City of L.A. RR25744 (concrete), RR25965 (masonry); Florida FL-17449.2 (concrete), FL-16230.3 (masonry); AASHTO M-235 and ASTM C881 (Type I and IV, Grade 3, Class C); NSF/ANSI Standard 61 (216 in.²/1,000 gal.)

Chemical Resistance

See pages 320–321.

Installation and Application Instructions

(See also pages 124–127.)

- Surfaces to receive epoxy must be clean.
- Base material temperature must be 50°F or above at the time of installation. For best results, material should be between 70°F and 80°F at time of application.
- To warm cold material, store cartridges in a warm, uniformly heated area or storage container. Do not immerse cartridges in water to facilitate warming.
- Mixed material in nozzle can harden in 30 minutes at temperatures of 70°F and above.



SET-XP® Adhesive

Design Example

See page 328.

Suggested Specifications

See www.strongtie.com for more information.



SET-XP® High-Strength Epoxy Adhesive

Test Criteria

Anchors installed with SET-XP® adhesive have been tested in accordance with ICC-ES *Acceptance Criteria for Post-Installed Adhesive Anchors in Masonry Elements (AC58)* and *Adhesive Anchors in Concrete Elements (AC308)*.

Property	Test Method	Result*
Consistency	ASTM C881	Passed, non-sag
Glass transition temperature	ASTM E1356	155°F
Bond strength (moist cure)	ASTM C882	3,742 psi at 2 days
Water absorption	ASTM D570	0.10%
Compressive yield strength	ASTM D695	14,830 psi
Compressive modulus	ASTM D695	644,000 psi
Shore D Durometer	ASTM D2240	84
Gel time	ASTM C881	49 minutes
Volatile Organic Compound (VOC)	—	3 g/L

*Material and curing conditions: 73 ± 2°F, unless otherwise noted.

SET-XP® Cartridge System

Model No.	Capacity (ounces)	Cartridge Type	Carton Quantity	Dispensing Tool(s)	Mixing Nozzle
SET-XP10 ⁴	8.5	Single	12	CDT10S	EMN22i
SET-XP22-N ⁵	22	Side-by-Side	10	EDT22S, EDTA22P, EDTA22CKT	
SET-XP56	56	Side-by-Side	6	EDTA56P	

1. Cartridge estimation guidelines are available at www.strongtie.com/apps.
2. Detailed information on dispensing tools, mixing nozzles and other adhesive accessories is available on pages 128 through 135, or at www.strongtie.com.
3. Use only Simpson Strong-Tie® mixing nozzles in accordance with Simpson Strong-Tie instructions. Modification or improper use of mixing nozzle may impair SET-XP adhesive performance.
4. Two EMN22i mixing nozzles and two nozzle extensions are supplied with each cartridge.
5. One EMN22i mixing nozzle and one nozzle extension are provided with each cartridge.

Cure Schedule

Base Material Temperature		Cure Time (hrs.)
°F	°C	
50	10	72
60	16	48
70	21	24
90	32	24
110	43	24

For water-saturated concrete, the cure times must be doubled.

SET-XP® Design Information — Concrete

SET-XP® Installation Information and Additional Data
for Threaded Rod and Rebar in Normal-Weight Concrete¹

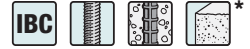

Characteristic	Symbol	Units	Nominal Anchor Diameter (in.) / Rebar Size						
			3/8 / #3	1/2 / #4	5/8 / #5	3/4 / #6	7/8 / #7	1 / #8	1 1/4 / #10
Installation Information									
Drill Bit Diameter	d_{hole}	in.	1/2	5/8	3/4	7/8	1	1 1/8	1 3/8
Maximum Tightening Torque	T_{inst}	ft.-lb.	10	20	30	45	60	80	125
Permitted Embedment Depth Range	Minimum	h_{ef}	2 3/8	2 3/4	3 1/8	3 1/2	3 3/4	4	5
	Maximum	h_{ef}	7 1/2	10	12 1/2	15	17 1/2	20	25
Minimum Concrete Thickness	h_{min}	in.	$h_{ef} + 5d_o$						
Critical Edge Distance ²	c_{ac}	in.	See footnote 2						
Minimum Edge Distance	c_{min}	in.	1 3/4						2 3/4
Minimum Anchor Spacing	s_{min}	in.	3						6

1. The information presented in this table is to be used in conjunction with the design criteria of ACI 318-11.

2. $c_{ac} = h_{ef} (\tau_{k,uncr} / 1160)^{0.4} \times [3.1 - 0.7(h/h_{ef})]$, where:

$$[h/h_{ef}] \leq 2.4$$

$\tau_{k,uncr}$ = the characteristic bond strength in uncracked concrete, given in the tables that follow $\leq k_{uncr} ((h_{ef} \times f'_c)^{0.5} / (l_T \times d_a))$

h = the member thickness (inches)

h_{ef} = the embedment depth (inches)

* See page 12 for an explanation of the load table icons.

SET-XP® Design Information — Concrete



SET-XP® Tension Strength Design Data for Threaded Rod in Normal-Weight Concrete¹

Characteristic		Symbol	Units	Nominal Anchor Diameter (in.)						
				3/8	1/2	5/8	3/4	7/8	1	1 1/4
Steel Strength in Tension										
Threaded Rod	Minimum Tensile Stress Area	A_{se}	in ²	0.078	0.142	0.226	0.334	0.462	0.606	0.969
	Tension Resistance of Steel — ASTM F1554, Grade 36	N_{sa}	lb.	4,525	8,235	13,110	19,370	26,795	35,150	56,200
	Tension Resistance of Steel — ASTM A193, Grade B7			9,750	17,750	28,250	41,750	57,750	75,750	121,125
	Tension Resistance of Steel — Type 410 Stainless (ASTM A193, Grade B6)			8,580	15,620	24,860	36,740	50,820	66,660	106,590
	Tension Resistance of Steel — Type 304 and 316 Stainless (ASTM A193, Grade B8 & B8M)			4,445	8,095	12,880	19,040	26,335	34,540	55,235
Strength Reduction Factor — Steel Failure	ϕ	—	0.75 ⁷							
Concrete Breakout Strength in Tension (2,500 psi ≤ f'_c ≤ 8,000 psi)¹²										
Effectiveness Factor — Uncracked Concrete		k_{uncr}	—	24						
Effectiveness Factor — Cracked Concrete		k_{cr}	—	17						
Strength Reduction Factor — Breakout Failure		ϕ	—	0.65 ⁹						
Bond Strength in Tension (2,500 psi ≤ f'_c ≤ 8,000 psi)¹²										
Uncracked Concrete ^{2,3,4}	Characteristic Bond Strength ^{5,13}	$\tau_{k,uncr}$	psi	770	1,150	1,060	970	885	790	620
	Permitted Embedment Depth Range	Minimum	h_{ef}	in.	2 3/8	2 3/4	3 1/8	3 1/2	3 3/4	4
Maximum		h_{ef}	in.	7 1/2	10	12 1/2	15	17 1/2	20	25
Cracked Concrete ^{2,3,4}	Characteristic Bond Strength ^{5,10,11,13}	$\tau_{k,cr}$	psi	595	510	435	385	355	345	345
	Permitted Embedment Depth Range	Minimum	h_{ef}	in.	3	4	5	6	7	8
Maximum		h_{ef}	in.	7 1/2	10	12 1/2	15	17 1/2	20	25
Bond Strength in Tension — Bond Strength Reduction Factors for Continuous Special Inspection										
Strength Reduction Factor — Dry Concrete		$\phi_{dry,ci}$	—	0.65 ⁸						
Strength Reduction Factor — Water-saturated Concrete — $h_{ef} \leq 12d_a$		$\phi_{sat,ci}$	—	0.55 ⁸			0.45 ⁸			
Additional Factor for Water-saturated Concrete — $h_{ef} \leq 12d_a$		$K_{sat,ci}$ ⁶	—	N/A			1		0.84	
Strength Reduction Factor — Water-saturated Concrete — $h_{ef} > 12d_a$		$\phi_{sat,ci}$	—	0.45 ⁸						
Additional Factor for Water-saturated Concrete — $h_{ef} > 12d_a$		$K_{sat,ci}$ ⁶	—	0.57						
Bond Strength in Tension — Bond Strength Reduction Factors for Periodic Special Inspection										
Strength Reduction Factor — Dry Concrete		$\phi_{dry,pi}$	—	0.55 ⁸						
Strength Reduction Factor — Water-saturated Concrete — $h_{ef} \leq 12d_a$		$\phi_{sat,pi}$	—	0.45 ⁸						
Additional Factor for Water-saturated Concrete — $h_{ef} \leq 12d_a$		$K_{sat,pi}$ ⁶	—	1			0.93		0.71	
Strength Reduction Factor — Water-saturated Concrete — $h_{ef} > 12d_a$		$\phi_{sat,pi}$	—	0.45 ⁸						
Additional Factor for Water-saturated Concrete — $h_{ef} > 12d_a$		$K_{sat,pi}$ ⁶	—	0.48						

- The information presented in this table is to be used in conjunction with the design criteria of ACI 318-11.
- Temperature Range: Maximum short-term temperature of 150°F. Maximum long-term temperature of 110°F.
- Short-term concrete temperatures are those that occur over short intervals (diurnal cycling).
- Long-term concrete temperatures are constant temperatures over a significant time period.
- For anchors that only resist wind or seismic loads, bond strengths may be increased by 72%.
- In water-saturated concrete, multiply $\tau_{k,uncr}$ and $\tau_{k,cr}$ by K_{sat} .
- The value of ϕ applies when the load combinations of ACI 318 Section 9.2 are used. If the load combinations of ACI 318 Appendix C are used, refer to Section D.4.4 to determine the appropriate value of ϕ .
- The value of ϕ applies when both the load combinations of ACI 318 Section 9.2 are used and the requirements of Section D.4.4 (c) for Condition B are met. If the load combinations of ACI 318 Appendix C are used, refer to Section D.4.4 to determine the appropriate value of ϕ .
- The value of ϕ applies when both the load combinations of ACI 318 Section 9.2 are used and the requirements of Section D.4.4 (c) for Condition B are met. If the load combinations of ACI 318 Section 9.2 are used and the requirements of Section D.4.4 (c) for Condition A are met, refer to Section D.4.4 to determine the appropriate value of ϕ . If the load combinations of ACI 318 Appendix C are used, refer to Section D.4.5 to determine the appropriate value of ϕ .
- For anchors installed in regions assigned to Seismic Design Category C, D, E or F, the bond strength values for 3/8" anchors must be multiplied by $\alpha_{N,seis} = 0.80$.
- For anchors installed in regions assigned to Seismic Design Category C, D, E or F, the bond strength values for 1" anchors must be multiplied by $\alpha_{N,seis} = 0.92$.
- The values of f'_c used for calculation purposes must not exceed 8,000 psi (55.1 MPa) for uncracked concrete. The value of f'_c used for calculation purposes must not exceed 2,500 psi (17.2 MPa) for tension resistance in cracked concrete.
- For applications where maximum short-term temperature is 110°F (43°C) and the maximum long-term temperature is 75°F (24°C), bond strengths may be increased 93%. No additional increase is permitted for anchors that only resist wind or seismic loads.

* See page 12 for an explanation of the load table icons.

SET-XP® Design Information — Concrete

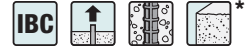
SET-XP® Tension Strength Design Data for Rebar in Normal-Weight Concrete¹

Characteristic		Symbol	Units	Rebar Size						
				#3	#4	#5	#6	#7	#8	#10
Steel Strength in Tension										
Rebar	Minimum Tensile Stress Area	A_{se}	in ²	0.11	0.2	0.31	0.44	0.6	0.79	1.23
	Tension Resistance of Steel — Rebar (ASTM A615 Grade 60)	N_{sa}	lb.	9,900	18,000	27,900	39,600	54,000	71,100	110,700
	Strength Reduction Factor — Steel Failure	ϕ	—	0.65 ⁷						
Concrete Breakout Strength in Tension (2,500 psi ≤ f'_c ≤ 8,000 psi)¹⁰										
Effectiveness Factor — Uncracked Concrete		k_{uncr}	—	24						
Effectiveness Factor — Cracked Concrete		k_{cr}	—	17						
Strength Reduction Factor — Breakout Failure		ϕ	—	0.65 ⁹						
Bond Strength in Tension (2,500 psi ≤ f'_c ≤ 8,000 psi)¹⁰										
Uncracked Concrete ^{2,3,4}	Characteristic Bond Strength ^{5,11}	$\tau_{k,uncr}$	psi	895	870	845	820	795	770	720
	Permitted Embedment Depth Range	Minimum	h_{ef}	in.	2 $\frac{3}{8}$	2 $\frac{3}{4}$	3 $\frac{1}{8}$	3 $\frac{1}{2}$	3 $\frac{3}{4}$	4
Maximum		h_{ef}	in.	7 $\frac{1}{2}$	10	12 $\frac{1}{2}$	15	17 $\frac{1}{2}$	20	25
Cracked Concrete ^{2,3,4}	Characteristic Bond Strength ^{5,11}	$\tau_{k,cr}$	psi	365	735	660	590	515	440	275
	Permitted Embedment Depth Range	Minimum	h_{ef}	in.	3	4	5	6	7	8
Maximum		h_{ef}	in.	7 $\frac{1}{2}$	10	12 $\frac{1}{2}$	15	17 $\frac{1}{2}$	20	25
Bond Strength in Tension — Bond Strength Reduction Factors for Continuous Special Inspection										
Strength Reduction Factor — Dry Concrete		$\phi_{dry,ci}$	—	0.65 ⁸						
Strength Reduction Factor — Water-saturated Concrete - $h_{ef} \leq 12d_a$		$\phi_{sat,ci}$	—	0.55 ⁸			0.45 ⁸			
Additional Factor for Water-saturated Concrete - $h_{ef} \leq 12d_a$		$K_{sat,ci}$ ⁶	—	N/A			1		0.84	
Strength Reduction Factor — Water-saturated Concrete - $h_{ef} > 12d_a$		$\phi_{sat,ci}$	—	0.45 ⁸						
Additional Factor for Water-saturated Concrete - $h_{ef} > 12d_a$		$K_{sat,ci}$ ⁶	—	0.57						
Bond Strength in Tension — Bond Strength Reduction Factors for Periodic Special Inspection										
Strength Reduction Factor — Dry Concrete		$\phi_{dry,pi}$	—	0.55 ⁸						
Strength Reduction Factor — Water-saturated Concrete - $h_{ef} \leq 12d_a$		$\phi_{sat,pi}$	—	0.45 ⁸						
Additional Factor for Water-saturated Concrete - $h_{ef} \leq 12d_a$		$K_{sat,pi}$ ⁶	—	1			0.93		0.71	
Strength Reduction Factor — Water-saturated Concrete - $h_{ef} > 12d_a$		$\phi_{sat,pi}$	—	0.45 ⁸						
Additional Factor for Water-saturated Concrete - $h_{ef} > 12d_a$		$K_{sat,pi}$ ⁶	—	0.48						

- The information presented in this table is to be used in conjunction with the design criteria of ACI 318-11.
- Temperature Range: Maximum short-term temperature of 150°F. Maximum long-term temperature of 110°F.
- Short-term concrete temperatures are those that occur over short intervals (diurnal cycling).
- Long-term concrete temperatures are constant temperatures over a significant time period.
- For anchors that only resist wind or seismic loads, bond strengths may be increased by 72%.
- In water-saturated concrete, multiply $\tau_{k,uncr}$ and $\tau_{k,cr}$ by K_{sat} .
- The value of ϕ applies when the load combinations of ACI 318 Section 9.2 are used. If the load combinations of ACI 318 Appendix C are used, refer to Section D.4.5 to determine the appropriate value of ϕ .
- The value of ϕ applies when both the load combinations of ACI 318 Section 9.2 are used and the requirements of Section D.4.4 (c) for Condition B are met. If the load combinations of ACI 318 Appendix C are used, refer to Section D.4.5 to determine the appropriate value of ϕ .
- The value of ϕ applies when both the load combinations of ACI 318 Section 9.2 are used and the requirements of Section D.4.4 (c) for Condition B are met. If the load combinations of ACI 318 Section 9.2 are used and the requirements of Section D.4.4 (c) for Condition A are met, refer to Section D.4.4 to determine the appropriate value of ϕ . If the load combinations of ACI 318 Appendix C are used, refer to Section D.4.5 to determine the appropriate value of ϕ .
- The values of f'_c used for calculation purposes must not exceed 8,000 psi (55.1 MPa) for uncracked concrete. The value of f'_c used for calculation purposes must not exceed 2,500 psi (17.2 MPa) for tension resistance in cracked concrete.
- For applications where maximum short-term temperature is 110°F (43°C) and the maximum long-term temperature is 75°F (24°C), bond strengths may be increased 93%. No additional increase is permitted for anchors that only resist wind or seismic loads.

* See page 12 for an explanation of the load table icons.

SET-XP® Design Information — Concrete

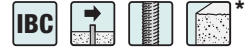
SET-XP® Shear Strength Design Data for Threaded Rod in Normal-Weight Concrete¹

Characteristic		Symbol	Units	Nominal Anchor Diameter (in.)						
				3/8	1/2	5/8	3/4	7/8	1	1 1/4
Steel Strength in Shear										
Threaded Rod	Minimum Shear Stress Area	A_{se}	in. ²	0.078	0.142	0.226	0.334	0.462	0.606	0.969
	Shear Resistance of Steel — ASTM F1554, Grade 36	V_{sa}	lb.	2,260	4,940	7,865	11,625	16,080	21,090	33,720
	Shear Resistance of Steel — ASTM A193, Grade B7			4,875	10,650	16,950	25,050	34,650	45,450	72,675
	Shear Resistance of Steel — Type 410 Stainless (ASTM A193, Grade B6)			4,290	9,370	14,910	22,040	30,490	40,000	63,955
	Shear Resistance of Steel — Type 304 and 316 Stainless (ASTM A193, Grade B8 & B8M)			2,225	4,855	7,730	11,420	15,800	20,725	33,140
	Reduction for Seismic Shear — ASTM F1554, Grade 36	$\alpha_{V,seis}$ ⁵	—	0.87	0.78	0.68				0.65
	Reduction for Seismic Shear — ASTM A193, Grade B7			0.87	0.78	0.68				0.65
	Reduction for Seismic Shear — Stainless (ASTM A193, Grade B6)			0.69	0.82	0.75		0.83	0.72	
	Reduction for Seismic Shear — Stainless (ASTM A193, Grade B8 & B8M)			0.69	0.82	0.75		0.83	0.72	
	Strength Reduction Factor — Steel Failure	ϕ	—	0.65 ²						
Concrete Breakout Strength in Shear										
Outside Diameter of Anchor	d_o	in.	0.375	0.5	0.625	0.75	0.875	1	1.25	
Load Bearing Length of Anchor in Shear	l_e	in.	h_{ef}							
Strength Reduction Factor — Breakout Failure	ϕ	—	0.70 ³							
Concrete Pryout Strength in Shear										
Coefficient for Pryout Strength	k_{cp}	—	1.0 for $h_{ef} < 2.50"$; 2.0 for $h_{ef} \geq 2.50"$							
Strength Reduction Factor — Pryout Failure	ϕ	—	0.70 ⁴							

- The information presented in this table is to be used in conjunction with the design criteria of ACI 318-11.
- The value of ϕ applies when the load combinations of ACI 318 Section 9.2 are used. If the load combinations of ACI 318 Appendix C are used, refer to Section D.4.4 to determine the appropriate value of ϕ .
- The value of ϕ applies when both the load combinations of ACI 318 Section 9.2 are used and the requirements of Section D.4.3 (c) for Condition B are met. If the load combinations of ACI 318 Section 9.2 are used and the requirements of Section D.4.3 (c) for Condition A are met, refer to Section D.4.3 to determine

- the appropriate value of ϕ . If the load combinations of ACI 318 Appendix C are used, refer to Section D.4.4 to determine the appropriate value of ϕ .
- The value of ϕ applies when both the load combinations of ACI 318 Section 9.2 are used and the requirements of Section D.4.3 (c) for Condition B are met. If the load combinations of ACI 318 Appendix C are used, refer to Section D.4.4 to determine the appropriate value of ϕ .
- The values of V_{sa} are applicable for both cracked concrete and uncracked concrete. For anchors installed in regions assigned to Seismic Design Category C, D, E or F, V_{sa} must be multiplied by $\alpha_{V,seis}$ for the corresponding anchor steel type.

* See page 12 for an explanation of the load table icons.

SET-XP® Design Information — Concrete



SET-XP® Shear Strength Design Data for Rebar in Normal-Weight Concrete¹

Characteristic	Symbol	Units	Rebar Size							
			#3	#4	#5	#6	#7	#8	#10	
Steel Strength in Shear										
Rebar	Minimum Shear Stress Area	A_{se}	in ²	0.11	0.2	0.31	0.44	0.6	0.79	1.23
	Shear Resistance of Steel — Rebar (ASTM A615 Grade 60)	V_{sa}	lb.	4,950	10,800	16,740	23,760	32,400	42,660	66,420
	Reduction for Seismic Shear — Rebar (ASTM A615 Grade 60)	$\alpha_{V,seis}^5$	—	0.85	0.88	0.84		0.77		0.59
	Strength Reduction Factor — Steel Failure	ϕ	—	0.60 ²						
Concrete Breakout Strength in Shear										
	Outside Diameter of Anchor	d_o	in.	0.375	0.5	0.625	0.75	0.875	1	1.25
	Load-Bearing Length of Anchor in Shear	l_e	in.	h_{ef}						
	Strength Reduction Factor — Breakout Failure	ϕ	—	0.70 ³						
Concrete Pryout Strength in Shear										
	Coefficient for Pryout Strength	k_{cp}	—	1.0 for $h_{ef} < 2.50"$; 2.0 for $h_{ef} \geq 2.50"$						
	Strength Reduction Factor — Pryout Failure	ϕ	—	0.70 ⁴						

1. The information presented in this table is to be used in conjunction with the design criteria of ACI 318-11.
2. The value of ϕ applies when the load combinations of ACI 318 Section 9.2 are used. If the load combinations of ACI 318 Appendix C are used, refer to Section D.4.4 to determine the appropriate value of ϕ .
3. The value of ϕ applies when both the load combinations of ACI 318 Section 9.2 are used and the requirements of Section D.4.3 (c) for Condition B are met. If the load combinations of ACI 318 Section 9.2 are used and the requirements of Section D.4.3 (c) for Condition A are met, refer to Section

D.4.3 to determine the appropriate value of ϕ . If the load combinations of ACI 318 Appendix C are used, refer to Section D.4.4 to determine the appropriate value of ϕ .

4. The value of ϕ applies when both the load combinations of ACI 318 Section 9.2 are used and the requirements of Section D.4.3 (c) for Condition B are met. If the load combinations of ACI 318 Appendix C are used, refer to Section D.4.4 to determine the appropriate value of ϕ .
5. The values of V_{sa} are applicable for both cracked concrete and uncracked concrete. For anchors installed in regions assigned to Seismic Design Category C, D, E or F, V_{sa} must be multiplied by $\alpha_{V,seis}$.

* See page 12 for an explanation of the load table icons.

SET-XP® Design Information — Concrete

SET-XP® Development Length for Rebar Dowels in Normal-Weight Concrete^{1,2,3,4,5,6}

Rebar Size	Top Cover in. (mm)	Development Length, in. (mm)				
		$f'_c = 2,500$ psi (17.2 MPa) Concrete	$f'_c = 3,000$ psi (20.7 MPa) Concrete	$f'_c = 4,000$ psi (27.6 MPa) Concrete	$f'_c = 6,000$ psi (41.4 MPa) Concrete	$f'_c = 8,000$ psi (55.2 MPa) Concrete
#3 (9.5)	1½ (38)	12 (305)	12 (305)	12 (305)	12 (305)	12 (305)
#4 (12.7)	1½ (38)	15 (381)	14 (356)	12 (305)	12 (305)	12 (305)
#5 (15.9)	1½ (38)	18 (457)	17 (432)	15 (381)	12 (305)	12 (305)
#6 (19.1)	1½ (38)	22 (559)	20 (508)	18 (457)	14 (356)	13 (330)
#7 (22.2)	3 (76)	32 (813)	29 (737)	25 (635)	21 (533)	18 (457)
#8 (25.4)	3 (76)	36 (914)	33 (838)	29 (737)	24 (610)	21 (533)
#9 (28.7)	3 (76)	41 (1041)	38 (965)	33 (838)	27 (686)	23 (584)
#10 (32.3)	3 (76)	46 (1168)	42 (1067)	37 (940)	30 (762)	26 (660)
#11 (35.8)	3 (76)	51 (1295)	47 (1194)	41 (1041)	33 (838)	29 (737)

1. Tabulated development lengths are for static, wind and seismic load cases in Seismic Design Category A and B.
2. Rebar is assumed to be ASTM A615 Grade 60 or A706 ($f_y = 60,000$ psi). For rebar with a higher yield strength, multiply tabulated values by $f_y / 60,000$ psi.
3. Concrete is assumed to be normal-weight concrete. For lightweight concrete, multiply tabulated values by 1.33.
4. Tabulated values assume bottom cover of less than 12 inches cast below rebars ($\Psi_t = 1.0$).
5. Uncoated rebar must be used.
6. The value of K_{tr} is assumed to be 0. Refer to ACI 318 Section 12.2.3.

SET-XP® Design Information — Concrete

SET-XP® Tension Design Strength for Threaded Rod Anchors in Normal-Weight Concrete ($f'_c = 2,500$ psi)

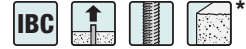

Adhesive Anchors

Rod Dia. (in.)	Nominal Embed. Depth (in.)	Minimum Dimensions for Uncracked (in.)		Minimum Dimensions for Cracked (in.)		Tension Design Strength Based on Concrete or Bond (lb.)							
						Edge Distances = c_{ac} on all sides				Edge Distances = $1\frac{3}{4}''$ on one side and c_{ac} on three sides			
						SDC A-B ⁶		SDC C-F ^{7,8}		SDC A-B ⁶		SDC C-F ^{7,8}	
						Uncracked	Cracked	Uncracked	Cracked	Uncracked	Cracked	Uncracked	Cracked
3/8	2 3/8	4 1/4	3 3/4	—	—	1,185	—	890	—	675	—	505	—
		5 3/4	3 5/8	—	—	—	—	—	—	800	—	600	—
	3	4 7/8	5	4 7/8	3 1/4	1,500	1,150	1,125	865	635	775	475	585
		7 1/4	4 1/2	—	—	—	—	—	—	880	—	660	—
	4 1/2	6 3/8	8 1/8	6 3/8	3 1/4	2,250	1,725	1,685	1,295	590	1,165	445	875
		10 7/8	6 3/4	—	—	—	—	—	—	880	—	660	—
6	7 7/8	11 1/8	7 7/8	4 3/8	2,995	2,300	2,250	1,725	570	1,555	430	1,165	
	14 1/2	9	—	—	—	—	—	—	880	—	660	—	
7 1/2	9 3/8	14 1/4	9 3/8	5 3/8	3,745	2,875	2,810	2,160	560	1,945	420	1,455	
	18	11 1/4	—	—	—	—	—	—	880	—	660	—	
1/2	2 3/4	5 1/4	5 1/8	—	—	2,730	—	2,050	—	1,470	—	1,105	—
		6 5/8	5 1/8	—	—	—	—	—	—	1,470	—	1,105	—
	4	6 1/2	7 7/8	6 1/2	5 1/8	3,975	1,755	2,980	1,315	1,400	945	1,050	710
		9 5/8	6	—	—	—	—	—	—	1,935	—	1,450	—
	6	8 1/2	12 5/8	8 1/2	5 1/8	5,960	2,635	4,470	1,975	1,300	1,420	975	1,065
		14 1/2	9	—	—	—	—	—	—	1,935	—	1,450	—
8	10 1/2	17 1/2	10 1/2	5 1/4	7,950	3,510	5,960	2,635	1,260	1,890	945	1,420	
	19 1/4	12	—	—	—	—	—	—	1,935	—	1,450	—	
10	12 1/2	22 1/4	12 1/2	6 3/8	9,935	4,390	7,450	3,290	1,235	2,365	925	1,775	
	24	15	—	—	—	—	—	—	1,935	—	1,450	—	
5/8	3 3/8	6 1/4	6 1/4	—	—	3,580	—	2,685	—	1,805	—	1,355	—
		7 1/2	6 1/4	—	—	—	—	—	—	1,805	—	1,355	—
	5	8 1/8	9 1/2	8 1/8	6 1/4	5,730	2,335	4,295	1,750	1,875	1,175	1,405	885
		12	7 1/2	—	—	—	—	—	—	2,590	—	1,945	—
	7 1/2	10 5/8	15 3/8	10 5/8	6 1/4	8,595	3,500	6,445	2,625	1,745	1,765	1,310	1,325
		18	11 1/4	—	—	—	—	—	—	2,590	—	1,945	—
12 1/2	15 5/8	26 7/8	15 5/8	7 5/8	14,320	5,830	10,740	4,375	1,655	2,945	1,240	2,210	
	30	18 3/4	—	—	—	—	—	—	2,590	—	1,945	—	
3/4	3 1/2	7 1/4	7 1/8	—	—	4,385	—	3,290	—	2,120	—	1,590	—
		8 1/2	7 1/8	—	—	—	—	—	—	2,120	—	1,590	—
	6	9 3/4	11	9 3/4	7 1/8	7,520	3,000	5,640	2,250	2,335	1,450	1,750	1,090
		14 1/2	9	—	—	—	—	—	—	3,230	—	2,420	—
	9	12 3/4	17 3/4	12 3/4	7 1/8	11,280	4,500	8,460	3,375	2,175	2,180	1,630	1,635
		21 5/8	13 1/2	—	—	—	—	—	—	3,230	—	2,420	—
15	18 3/4	31 1/8	18 3/4	9	18,795	7,505	14,100	5,625	2,060	3,630	1,545	2,720	
	36	22 1/2	—	—	—	—	—	—	3,230	—	2,420	—	
7/8	3 3/4	8 1/8	7 7/8	—	—	5,020	—	3,010	—	2,355	—	1,410	—
		9	7 7/8	—	—	—	—	—	—	2,355	—	1,410	—
	7	11 3/8	12 3/8	11 3/8	7 7/8	9,365	3,745	5,620	2,250	2,795	1,755	1,680	1,055
		16 7/8	10 1/2	—	—	—	—	—	—	3,865	—	2,320	—
	10 1/2	14 7/8	19 7/8	14 7/8	7 7/8	14,050	5,620	8,430	3,370	2,605	2,635	1,560	1,580
		25 1/4	15 3/4	—	—	—	—	—	—	3,865	—	2,320	—
17 1/2	21 7/8	35	21 7/8	10	23,415	9,365	14,050	5,620	2,465	4,390	1,480	2,635	
	42	26 1/4	—	—	—	—	—	—	3,865	—	2,320	—	
1	4	9	8 1/2	—	—	5,455	—	3,765	—	2,505	—	1,730	—
		9 5/8	8 1/2	—	—	—	—	—	—	2,505	—	1,730	—
	8	13	13 1/2	13	8 1/2	10,905	4,755	7,525	3,280	3,155	2,185	2,175	1,510
		19 1/4	12	—	—	—	—	—	—	4,360	—	3,010	—
	12	17	21 3/4	17	8 1/2	16,360	7,135	11,290	4,920	2,935	3,280	2,025	2,265
		28 7/8	18	—	—	—	—	—	—	4,360	—	3,010	—
20	25	38 1/4	25	12 1/4	27,265	11,890	18,815	8,205	2,785	5,465	1,920	3,770	
	48	30	—	—	—	—	—	—	4,360	—	3,010	—	
1 1/4	5	11 1/4	9 1/2	—	—	6,705	—	5,030	—	—	—	—	—
		12	9 1/2	—	—	—	—	—	—	—	—	—	—
	10	16 1/4	15 3/8	16 1/4	9 1/2	13,415	7,430	10,060	5,570	—	—	—	—
		24	15	—	—	—	—	—	—	—	—	—	—
	15	21 1/4	24 3/4	21 1/4	11 1/8	20,120	11,145	15,090	8,360	—	—	—	—
		36	22 1/2	—	—	—	—	—	—	—	—	—	—
25	31 1/4	43 3/8	31 1/4	15 3/8	33,530	18,575	25,150	13,930	—	—	—	—	
	60	37 1/2	—	—	—	—	—	—	—	—	—	—	

Threaded Rod Dia. (in.)	Tension Design Strength of Threaded Rod Steel (lb)					
	ASTM F1554, GR 36	ASTM F1554, GR 55	ASTM F1554, GR 105	ASTM A193, B6	ASTM A193, B7	ASTM A193, B8/B8M
3/8	3,370	4,360	7,270	6,395	7,270	3,310
1/2	6,175	7,990	13,315	11,715	13,315	6,070
5/8	9,835	12,715	21,190	18,645	21,190	9,660
3/4	14,530	18,790	31,315	27,555	31,315	14,280
7/8	20,095	25,990	43,315	38,115	43,315	19,750
1	26,365	34,090	56,815	49,995	56,815	25,905
1 1/4	42,150	54,505	90,845	79,945	90,845	41,425

- Tension design strength must be the lesser of the concrete, bond or threaded rod steel design strength.
- Tension design strengths are based on the strength design provisions of ACI 318-11 Appendix D assuming dry concrete, periodic inspection, short-term temperature of 150°F and long-term temperature of 110°F.
- Tabulated values are for a single anchor with no influence of another anchor.
- Interpolation between embedment depths is not permitted.
- Strength reduction factor, ϕ , is based on using a load combination from ACI 318-11 Section 9.2.
- The tension design strength listed for SDC (Seismic Design Category) A-B may also be used in SDC C-F when the tension component of the strength-level seismic design load on the anchor does not exceed 20% of the total factored tension load on the anchor associated with the same load combination.
- When designing anchorages in SDC C-F, the Designer shall consider the ductility requirements of ACI 318-11 Section D.3.3. Design strengths in **Bold** indicate that the anchor ductility requirements of D.3.3.4.3 (a)1 to 3 are satisfied when using ASTM F1554 Grade 36 threaded rod. Any other ductility requirements must be satisfied.
- Tension design strengths in SDC C-F have been adjusted by 0.75 factor in accordance with ACI 318-11 Section D.3.3.4.4.

* See page 12 for an explanation of the load table icons.

SET-XP® Design Information — Concrete

SET-XP® Allowable Tension Loads for Threaded Rod Anchors in Normal-Weight Concrete (f_c = 2,500 psi) — Static Load

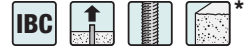

Rod Dia. (in.)	Nominal Embed. Depth (in.)	Minimum Dimensions for Uncracked (in.)		Minimum Dimensions for Cracked (in.)		Allowable Tension Load Based on Concrete or Bond (lb.)			
		h _a	C _{ac}	h _a	C _{ac}	Edge distances = C _{ac} on all sides		Edge Distances = 1 ¼" on one side and C _{ac} on three sides	
						Uncracked	Cracked	Uncracked	Cracked
¾	2 ¾	4 ¼	3 ¾	—	—	845	—	480	—
		5 ¾	3 ¾	—	—			570	—
	3	4 ¾	5	4 ¾	3 ¼	1,070	820	455	555
		7 ¼	4 ½					630	
	4 ½	6 ¾	8 ½	6 ¾	3 ¼	1,605	1,230	420	830
		10 7/8	6 ¾					630	
6	7 7/8	11 1/8	7 7/8	4 ¾	2,140	1,645	405	1,110	
	14 ½	9					630		
7 ½	9 ¾	14 ¼	9 ¾	5 ¾	2,675	2,055	400	1,390	
	18	11 ¼					630		
½	2 ¾	5 ¼	5 ½	—	—	1,950	—	1,050	—
		6 ¾	5 ½	—	—			1,050	—
	4	6 ½	7 7/8	6 ½	5 ½	2,840	1,255	1,000	675
		9 ¾	6					1,380	
	6	8 ½	12 5/8	8 ½	5 ½	4,255	1,880	930	1,015
		14 ½	9					1,380	
8	10 ½	17 ½	10 ½	5 ¼	5,680	2,505	900	1,350	
	19 ¼	12					1,380		
10	12 ½	22 ¼	12 ½	6 ¾	7,095	3,135	880	1,690	
	24	15					1,380		
5/8	3 ¾	6 ¼	6 ¼	—	—	2,555	—	1,290	—
		7 ½	6 ¼	—	—			1,290	—
	5	8 ½	9 ½	8 ½	6 ¼	4,095	1,670	1,340	840
		12	7 ½					1,850	
7 ½	10 5/8	15 3/8	10 5/8	6 ¼	6,140	2,500	1,245	1,260	
	18	11 ¼					1,850		
12 ½	15 5/8	26 7/8	15 5/8	7 ¾	10,230	4,165	1,180	2,105	
	30	18 ¾					1,850		
¾	3 ½	7 ¼	7 ½	—	—	3,130	—	1,515	—
		8 ½	7 ½	—	—			1,515	—
	6	9 ¾	11	9 ¾	7 ½	5,370	2,145	1,670	1,035
		14 ½	9					2,305	
	9	12 ¾	17 ¾	12 ¾	7 ½	8,055	3,215	1,555	1,555
		21 5/8	13 ½					2,305	
15	18 ¾	31 ½	18 ¾	9	13,425	5,360	1,470	2,595	
	36	22 ½					2,305		
7/8	3 ¾	8 ½	7 7/8	—	—	3,585	—	1,680	—
		9	7 7/8	—	—			1,680	—
	7	11 5/8	12 3/8	11 5/8	7 7/8	6,690	2,675	1,995	1,255
		16 7/8	10 ½					2,760	
10 ½	14 7/8	19 7/8	14 7/8	7 7/8	10,035	4,015	1,860	1,880	
	25 ¼	15 ¾					2,760		
17 ½	21 7/8	35	21 7/8	10	16,725	6,690	1,760	3,135	
	42	26 ¼					2,760		
1	4	9	8 ½	—	—	3,895	—	1,790	—
		9 ¾	8 ½	—	—			1,790	—
	8	13	13 ½	13	8 ½	7,790	3,395	2,255	1,560
		19 ¼	12					3,115	
	12	17	21 ¾	17	8 ½	11,685	5,095	2,095	2,345
		28 7/8	18					3,115	
20	25	38 ¼	25	12 ¼	19,475	8,495	1,990	3,905	
	48	30					3,115		
1 ¼	5	11 ¼	9 ½	—	—	4,790	—	—	—
		12	9 ½	—	—			—	—
	10	16 ¼	15 3/8	16 ¼	9 ½	9,580	5,305	—	—
		24	15					—	
15	21 ¼	24 ¾	21 ¼	11 ½	14,370	7,960	—	—	
	36	22 ½					—		
25	31 ¼	43 3/8	31 ¼	15 5/8	23,950	13,270	—	—	
	60	37 ½					—		

Adhesive Anchors

Threaded Rod Dia. (in.)	Allowable Tension Load of Threaded Rod Steel (lb.)					
	ASTM F1554, GR 36	ASTM F1554, GR 55	ASTM F1554, GR 105	ASTM A193, B6	ASTM A193, B7	ASTM A193, B8/B8M
¾	2,405	3,115	5,195	4,570	5,195	2,365
½	4,410	5,705	9,510	8,370	9,510	4,335
5/8	7,025	9,080	15,135	13,320	15,135	6,900
¾	10,380	13,420	22,370	19,680	22,370	10,200
7/8	14,355	18,565	30,940	27,225	30,940	14,105
1	18,830	24,350	40,580	35,710	40,580	18,505
1 ¼	30,105	38,930	64,890	57,105	64,890	29,590

1. Allowable tension load must be the lesser of the concrete, bond or threaded rod steel load.
2. Allowable tension loads are calculated based on the strength design provisions of ACI 318-11 Appendix D assuming dry concrete, periodic inspection, short-term temperature of 150°F and long-term temperature of 110°F. Tension design strengths are converted to allowable tension loads using a conversion factor of a = 1.4. The conversion factor a is based on the load combination 1.2D + 1.6L assuming 50% dead load and 50% live load: 1.2(0.5) + 1.6(0.5) = 1.4.
3. Tabulated values are for a single anchor with no influence of another anchor.
4. Interpolation between embedment depths is not permitted.

* See page 12 for an explanation of the load table icons.

SET-XP® Design Information — Concrete

SET-XP® Allowable Tension Loads for Threaded Rod Anchors in Normal-Weight Concrete (f'c = 2,500 psi) — Wind Load

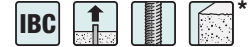

Adhesive Anchors

Rod Dia. (in.)	Nominal Embed. Depth (in.)	Minimum Dimensions for Uncracked (in.)		Minimum Dimensions for Cracked (in.)		Allowable Tension Load Based on Concrete or Bond (lb.)			
		ha	cac	ha	cac	Edge distances = cac on all sides		Edge Distances = 1¼" on one side and cac on three sides	
						Uncracked	Cracked	Uncracked	Cracked
¾	2¾	4¼	3¾	—	—	710	—	405	—
		5¾	3¾	—	—			480	—
	3	4¾	5	4¾	3¼	900	690	380	465
		7¼	4½					530	
	4½	6¾	8½	6¾	3¼	1,350	1,035	355	700
		10¾	6¾					530	
6	7¾	11½	7¾	4¾	1,795	1,380	340	935	
	14½	9					530		
7½	9¾	14¼	9¾	5¾	2,245	1,725	335	1,165	
	18	11¼					530		
½	2¾	5¼	5½	—	—	1,640	—	880	—
		6¾	5½	—	—			880	—
	4	6½	7¾	6½	5½	2,385	1,055	840	565
		9¾	6					1,160	
	6	8½	12¾	8½	5½	3,575	1,580	780	850
		14½	9					1,160	
8	10½	17½	10½	5¼	4,770	2,105	755	1,135	
	19¼	12					1,160		
10	12½	22¼	12½	6¾	5,960	2,635	740	1,420	
	24	15					1,160		
⅝	3¾	6¼	6¼	—	—	2,150	—	1,085	—
		7½	6¼	—	—			1,085	—
	5	8½	9½	8½	6¼	3,440	1,400	1,125	705
		12	7½					1,555	
7½	10¾	15¾	10¾	6¼	5,155	2,100	1,045	1,060	
	18	11¼					1,555		
12½	15¾	26¾	15¾	7¾	8,590	3,500	995	1,765	
	30	18¾					1,555		
¾	3½	7¼	7½	—	—	2,630	—	1,270	—
		8½	7½	—	—			1,270	—
	6	9¾	11	9¾	7½	4,510	1,800	1,400	870
		14½	9					1,940	
9	12¾	17¾	12¾	7½	6,770	2,700	1,305	1,310	
	21¾	13½					1,940		
15	18¾	31½	18¾	9	11,275	4,505	1,235	2,180	
	36	22½					1,940		
⅞	3¾	8½	7¾	—	—	3,010	—	1,415	—
		9	7¾	—	—			1,415	—
	7	11¾	12¾	11¾	7¾	5,620	2,245	1,675	1,055
		16¾	10½					2,320	
10½	14¾	19¾	14¾	7¾	8,430	3,370	1,565	1,580	
	25¼	15¾					2,320		
17½	21¾	35	21¾	10	14,050	5,620	1,480	2,635	
	42	26¼					2,320		
1	4	9	8½	—	—	3,275	—	1,505	—
		9¾	8½	—	—			1,505	—
	8	13	13½	13	8½	6,545	2,855	1,895	1,310
		19¼	12					2,615	
12	17	21¼	17	8½	9,815	4,280	1,760	1,970	
	28¾	18					2,615		
20	25	38¼	25	12¼	16,360	7,135	1,670	3,280	
	48	30					2,615		
1¼	5	11¼	9½	—	—	4,025	—	—	—
		12	9½	—	—			—	—
	10	16¼	15¾	16¼	9½	8,050	4,460	—	—
		24	15					—	—
15	21¼	24¾	21¼	11¾	12,070	6,685	—	—	
	36	22½					—	—	
25	31¼	43¾	31¼	15¾	20,120	11,145	—	—	
	60	37½					—	—	

Threaded Rod Dia. (in.)	Allowable Tension Load of Threaded Rod Steel (lb.)					
	ASTM F1554 GR 36	ASTM F1554 GR 55	ASTM F1554 GR 105	ASTM A193 B6	ASTM A193 B7	ASTM A193 B8/B8M
¾	2,020	2,615	4,360	3,835	4,360	1,985
½	3,705	4,795	7,990	7,030	7,990	3,640
⅝	5,900	7,630	12,715	11,185	12,715	5,795
¾	8,720	11,275	18,790	16,535	18,790	8,570
⅞	12,055	15,595	25,990	22,870	25,990	11,850
1	15,820	20,455	34,090	29,995	34,090	15,545
1¼	25,290	32,705	54,505	47,965	54,505	24,855

1. Allowable tension load must be the lesser of the concrete, bond or threaded rod steel load.
2. Allowable tension loads are calculated based on the strength design provisions of ACI 318-11 Appendix D assuming dry concrete, periodic inspection, short-term temperature of 150°F and long-term temperature of 110°F. Tension design strengths are converted to allowable tension loads using a conversion factor of $\alpha = 1/1.67 = 0.6$. The conversion factor α is based on the load combination assuming 100% wind load.
3. Tabulated values are for a single anchor with no influence of another anchor.
4. Interpolation between embedment depths is not permitted.

* See page 12 for an explanation of the load table icons.

SET-XP® Design Information — Concrete

SET-XP® Allowable Tension Loads for Threaded Rod Anchors in Normal-Weight Concrete (f'c = 2,500 psi) — Seismic Load

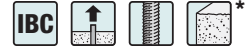

Nom. Insert Diam. (in.)	Embed. Depth, h _{ef} (in.)	Minimum Dimensions for Uncracked (in.)		Minimum Dimensions for Cracked (in.)		Allowable Tension Load Based on Concrete or Bond (lb.)							
		h _a	c _{ac}	h _a	c _{ac}	Edge Distances = c _{ac} on all sides				Edge Distances = 1 3/4" on one side and c _{ac} on three sides			
						SDC A-B ⁵		SDC C-F ^{6,7}		SDC A-B ⁵		SDC C-F ^{6,7}	
Uncracked	Cracked	Uncracked	Cracked	Uncracked	Cracked	Uncracked	Cracked	Uncracked	Cracked	Uncracked	Cracked		
3/8	2 3/8	4 1/4	3 3/4	—	—	830	—	625	—	475	—	355	—
		5 3/4	3 3/8	—	—	—	—	—	—	560	—	420	—
	3	4 7/8	5	4 7/8	3 1/4	1,050	805	790	605	445	545	335	410
		7 1/4	4 1/2	—	—	—	—	—	—	615	—	460	—
	4 1/2	6 3/8	8 1/8	6 3/8	3 1/4	1,575	1,210	1,180	905	415	815	310	615
		10 7/8	6 3/4	—	—	—	—	—	—	615	—	460	—
6	7 7/8	11 1/8	7 7/8	4 3/8	2,095	1,610	1,575	1,210	400	1,090	300	815	
	14 1/2	9	—	—	—	—	—	—	615	—	460	—	
7 1/2	9 3/8	14 1/4	9 3/8	5 3/8	2,620	2,015	1,965	1,510	390	1,360	295	1,020	
	18	11 1/4	—	—	—	—	—	—	615	—	460	—	
1/2	2 3/4	5 1/4	5 1/8	—	—	1,910	—	1,435	—	1,030	—	775	—
		6 3/8	5 3/8	—	—	—	—	—	—	1,030	—	775	—
	4	6 1/2	7 7/8	6 1/2	5 1/8	2,785	1,230	2,085	920	980	660	735	495
		9 3/8	6	—	—	—	—	—	—	1,355	—	1,015	—
	6	8 1/2	12 5/8	8 1/2	5 1/8	4,170	1,845	3,130	1,385	910	995	685	745
		14 1/2	9	—	—	—	—	—	—	1,355	—	1,015	—
8	10 1/2	17 1/2	10 1/2	5 1/4	5,565	2,455	4,170	1,845	880	1,325	660	995	
	19 1/4	12	—	—	—	—	—	—	1,355	—	1,015	—	
10	12 1/2	22 1/4	12 1/2	6 3/8	6,955	3,075	5,215	2,305	865	1,655	650	1,245	
	24	15	—	—	—	—	—	—	1,355	—	1,015	—	
5/8	3 1/8	6 1/4	6 1/4	—	—	2,505	—	1,880	—	1,265	—	950	—
		7 1/2	6 1/4	—	—	—	—	—	—	1,265	—	950	—
	5	8 1/8	9 1/2	8 1/8	6 1/4	4,010	1,635	3,005	1,225	1,315	825	985	620
		12	7 1/2	—	—	—	—	—	—	1,815	—	1,360	—
7 1/2	10 5/8	15 3/8	10 5/8	6 1/4	6,015	2,450	4,510	1,840	1,220	1,235	915	930	
	18	11 1/4	—	—	—	—	—	—	1,815	—	1,360	—	
12 1/2	15 5/8	26 7/8	15 5/8	7 5/8	10,025	4,080	7,520	3,065	1,160	2,060	870	1,545	
	30	18 3/4	—	—	—	—	—	—	1,815	—	1,360	—	
3/4	3 1/2	7 1/4	7 1/8	—	—	3,070	—	2,305	—	1,485	—	1,115	—
		8 1/2	7 3/8	—	—	—	—	—	—	1,485	—	1,115	—
	6	9 3/4	11	9 3/4	7 1/8	5,265	2,100	3,950	1,575	1,635	1,015	1,225	765
		14 1/2	9	—	—	—	—	—	—	2,260	—	1,695	—
9	12 3/4	17 3/4	12 3/4	7 1/8	7,895	3,150	5,920	2,365	1,525	1,525	1,140	1,145	
	21 5/8	13 1/2	—	—	—	—	—	—	2,260	—	1,695	—	
15	18 3/4	31 1/8	18 3/4	9	13,155	5,255	9,870	3,940	1,440	2,540	1,080	1,905	
	36	22 1/2	—	—	—	—	—	—	2,260	—	1,695	—	
7/8	3 3/4	8 1/8	7 7/8	—	—	3,515	—	2,105	—	1,650	—	985	—
		9	7 7/8	—	—	—	—	—	—	1,650	—	985	—
	7	11 3/8	12 3/8	11 3/8	7 7/8	6,555	2,620	3,935	1,575	1,955	1,230	1,175	740
		16 7/8	10 1/2	—	—	—	—	—	—	2,705	—	1,625	—
10 1/2	14 7/8	19 7/8	14 7/8	7 7/8	9,835	3,935	5,900	2,360	1,825	1,845	1,090	1,105	
	25 1/4	15 3/4	—	—	—	—	—	—	2,705	—	1,625	—	
17 1/2	21 7/8	35	21 7/8	10	16,390	6,555	9,835	3,935	1,725	3,075	1,035	1,845	
	42	26 1/4	—	—	—	—	—	—	2,705	—	1,625	—	
1	4	9	8 1/2	—	—	3,820	—	2,635	—	1,755	—	1,210	—
		9 3/8	8 1/2	—	—	—	—	—	—	1,755	—	1,210	—
	8	13	13 1/2	13	8 1/2	7,635	3,330	5,270	2,295	2,210	1,530	1,525	1,055
		19 1/4	12	—	—	—	—	—	—	3,050	—	2,105	—
12	17	21 3/4	17	8 1/2	11,450	4,995	7,905	3,445	2,055	2,295	1,420	1,585	
	28 7/8	18	—	—	—	—	—	—	3,050	—	2,105	—	
20	25	38 1/4	25	12 1/4	19,085	8,325	13,170	5,745	1,950	3,825	1,345	2,640	
	48	30	—	—	—	—	—	—	3,050	—	2,105	—	
1 1/4	5	11 1/4	9 1/2	—	—	4,695	—	3,520	—	—	—	—	—
		12	9 1/2	—	—	—	—	—	—	—	—	—	—
	10	16 1/4	15 3/8	16 1/4	9 1/2	9,390	5,200	7,040	3,900	—	—	—	—
		24	15	—	—	—	—	—	—	—	—	—	—
15	21 1/4	24 3/4	21 1/4	11 1/8	14,085	7,800	10,565	5,850	—	—	—	—	
	36	22 1/2	—	—	—	—	—	—	—	—	—	—	
25	31 1/4	43 3/8	31 1/4	15 3/8	23,470	13,005	17,605	9,750	—	—	—	—	
	60	37 1/2	—	—	—	—	—	—	—	—	—	—	

Adhesive Anchors

Threaded Rod Dia. (in.)	Allowable Tension Load of Threaded Rod Steel (lb.)					
	ASTM F1554 GR 36	ASTM F1554 GR 55	ASTM F1554 GR 105	ASTM A193 B6	ASTM A193 B7	ASTM A193 B8/B8M
3/8	2,360	3,050	5,090	4,475	5,090	2,315
1/2	4,325	5,595	9,320	8,200	9,320	4,250
5/8	6,885	8,900	14,835	13,050	14,835	6,760
3/4	10,170	13,155	21,920	19,290	21,920	9,995
7/8	14,065	18,195	30,320	26,680	30,320	13,825
1	18,455	23,865	39,770	34,995	39,770	18,135
1 1/4	29,505	38,155	63,590	55,960	63,590	29,000

- Allowable tension load must be the lesser of the concrete, bond or threaded rod steel load.
- Tabulated values are for a single anchor with no influence of another anchor.
- Interpolation between embedment depths is not permitted.
- See page 12 for an explanation of the load table icons.
- The allowable tension load listed for SDC (Seismic Design Category) A-B may also be used in SDC C-F when the tension component of the strength-level seismic design load on the anchor does not exceed 20% of the total factored tension load on the anchor associated with the same load combination.
- When designing anchorages in SDC C-F, the Designer shall consider the ductility requirements of ACI 318-11 Section D.3.3. Design strengths in **Bold** indicate that the anchor ductility requirements of D.3.3.4.3 (a) 1 to 3 are satisfied when using ASTM F1554 Grade 36 threaded rod. Any other ductility requirements must be satisfied.
- Allowable tension loads in SDC C-F have been adjusted by 0.75 factor in accordance with ACI 318-11 Section D.3.3.4.4.

SET-XP® Design Information — Concrete



SET-XP® Tension Design Strength for Rebar in Normal-Weight Concrete ($f'_c = 2,500$ psi)

Adhesive Anchors

Rebar Size	Nominal Embed. Depth (in.)	Minimum Dimensions for Uncracked (in.)		Minimum Dimensions for Cracked (in.)		Tension Design Strength Based on Concrete or Bond (lb.)							
		h_a	c_{ac}	h_a	c_{ac}	Edge Distances = c_{ac} on all sides				Edge Distances = $1\frac{3}{4}$ " on one side and c_{ac} on three sides			
						SDC A-B ⁶		SDC C-F ^{7,8}		SDC A-B ⁶		SDC C-F ^{7,8}	
		Uncracked	Cracked	Uncracked	Cracked	Uncracked	Cracked	Uncracked	Cracked				
#3	2½	4¼	4	—	—	1,380	—	1,035	—	765	—	575	—
		5¾	3½	—	—	—	—	—	—	895	—	670	—
	3	4¾	5½	4¾	3½	1,740	700	1,305	525	720	455	540	340
		7¼	4½	—	—	—	—	—	—	995	—	745	—
	4½	6¾	8½	6¾	3½	2,615	1,055	1,960	790	670	685	505	510
		10⅞	6¾	—	—	—	—	—	—	995	—	745	—
6	7¾	11¾	7¾	3½	3,485	1,405	2,615	1,055	650	910	485	685	
	14½	9	—	—	—	—	—	—	995	—	745	—	
7½	9¾	15½	9¾	3½	4,355	1,755	3,265	1,315	635	1,140	475	855	
	18	11¼	—	—	—	—	—	—	995	—	745	—	
#4	2¾	5¼	4½	—	—	2,065	—	1,550	—	1,180	—	885	—
		6½	4½	—	—	—	—	—	—	1,180	—	885	—
	4	6½	7	6½	4½	3,005	2,525	2,255	1,895	1,090	1,440	815	1,080
		9½	6	—	—	—	—	—	—	1,505	—	1,130	—
	6	8½	11¾	8½	5½	4,510	3,790	3,380	2,840	1,015	2,035	760	1,525
		14½	9	—	—	—	—	—	—	1,505	—	1,130	—
8	10½	15½	10½	6½	6,015	5,050	4,510	3,790	980	2,525	735	1,895	
	19¼	12	—	—	—	—	—	—	1,505	—	1,130	—	
10	12½	19¾	12½	7½	7,515	6,315	5,635	4,735	960	2,995	720	2,245	
	24	15	—	—	—	—	—	—	1,505	—	1,130	—	
#5	3½	6¼	5½	—	—	2,860	—	2,145	—	1,500	—	1,125	—
		7½	5½	—	—	—	—	—	—	1,500	—	1,125	—
	5	8½	8¾	8½	5½	4,575	3,560	3,430	2,670	1,520	1,865	1,140	1,400
		12	7½	—	—	—	—	—	—	2,105	—	1,575	—
	7½	10½	14	10½	6¾	6,860	5,340	5,145	4,005	1,415	2,640	1,060	1,980
18		11¼	—	—	—	—	—	—	2,105	—	1,575	—	
12½	15½	24½	15½	9½	11,435	8,895	8,575	6,670	1,340	4,005	1,005	3,005	
	30	18¾	—	—	—	—	—	—	2,105	—	1,575	—	
#6	3½	7¼	6½	—	—	3,725	—	2,795	—	1,845	—	1,385	—
		8½	6½	—	—	—	—	—	—	1,845	—	1,385	—
	6	9¾	10¾	9¾	6½	6,385	4,555	4,790	3,415	2,000	2,260	1,500	1,695
		14½	9	—	—	—	—	—	—	2,765	—	2,075	—
	9	12¾	16½	12¾	8½	9,575	6,835	7,180	5,125	1,860	3,235	1,395	2,425
		21½	13½	—	—	—	—	—	—	2,765	—	2,075	—
15	18¾	29½	18¾	11¾	15,960	11,390	11,970	8,545	1,765	4,965	1,325	3,725	
	36	22½	—	—	—	—	—	—	2,765	—	2,075	—	
#7	3¾	8½	7½	—	—	4,505	—	3,380	—	2,145	—	1,610	—
		9	7½	—	—	—	—	—	—	2,145	—	1,610	—
	7	11¾	11¾	11¾	7½	8,415	5,430	6,310	4,070	2,525	2,585	1,890	1,940
		16¾	10½	—	—	—	—	—	—	3,485	—	2,615	—
	10½	14¾	19½	14¾	9½	12,620	8,145	9,465	6,110	2,350	3,740	1,760	2,805
25¼		15¾	—	—	—	—	—	—	3,485	—	2,615	—	
17½	21¾	33½	21¾	12¾	21,035	13,575	15,775	10,180	2,225	5,770	1,670	4,330	
	42	26¼	—	—	—	—	—	—	3,485	—	2,615	—	
#8	4	9	8¾	—	—	5,330	—	3,995	—	2,455	—	1,845	—
		9½	8¾	—	—	—	—	—	—	2,455	—	1,845	—
	8	13	13¾	13	8¾	10,660	6,095	7,995	4,570	3,085	2,810	2,315	2,110
		19¼	12	—	—	—	—	—	—	4,265	—	3,200	—
	12	17	21½	17	9¾	15,985	9,145	11,990	6,860	2,870	4,070	2,155	3,055
28¾		18	—	—	—	—	—	—	4,265	—	3,200	—	
20	25	37¾	25	13¾	26,645	15,240	19,985	11,430	2,720	6,380	2,040	4,785	
	48	30	—	—	—	—	—	—	4,265	—	3,200	—	
#10	5	11¼	10½	—	—	7,765	—	5,825	—	—	—	—	—
		12	10½	—	—	—	—	—	—	—	—	—	—
	10	16¼	16¼	16¼	10½	15,530	5,940	11,645	4,455	—	—	—	—
		24	15	—	—	—	—	—	—	—	—	—	—
	15	21¼	26½	21¼	10½	23,295	8,910	17,470	6,680	—	—	—	—
36		22½	—	—	—	—	—	—	—	—	—	—	
25	31¼	46	31¼	13½	38,825	14,850	29,115	11,135	—	—	—	—	
	60	37½	—	—	—	—	—	—	—	—	—	—	

Rebar Size	Tension Design Strength of Rebar Steel (lb.)	
	ASTM A615 GR 60	ASTM A706 GR 60
#3	6,435	5,720
#4	11,700	10,400
#5	18,135	16,120
#6	25,740	22,880
#7	35,100	31,200
#8	46,215	41,080
#10	74,100	66,040

1. Tension design strength must be the lesser of the concrete, bond or rebar steel design strength.
2. Tension design strengths are based on the strength design provisions of ACI 318-11 Appendix D assuming dry concrete, periodic inspection, short-term temperature of 150°F and long-term temperature of 110°F.
3. Tabulated values are for a single anchor with no influence of another anchor.
4. Interpolation between embedment depths is not permitted.
5. Strength reduction factor, ϕ , is based on using a load combination from ACI 318-11 Section 9.2.
6. The tension design strength listed for SDC (Seismic Design Category) A-B may also be used in SDC C-F when the tension component of the strength-level seismic design load on the anchor does not exceed 20% of the total factored tension load on the anchor associated with the same load combination.
7. When designing anchorages in SDC C-F, the Designer shall consider the ductility requirements of ACI 318-11 Section D.3.3.
8. Tension design strengths in SDC C-F have been adjusted by 0.75 factor in accordance with ACI 318-11 Section D.3.3.4.4.

* See page 12 for an explanation of the load table icons.

SET-XP® Design Information — Concrete

SET-XP® Allowable Tension Loads for Rebar in Normal-Weight Concrete
(f'c = 2,500 psi) — Static Load



Rebar Size	Nominal Embed. Depth (in.)	Minimum Dimensions for Uncracked (in.)		Minimum Dimensions for Cracked (in.)		Allowable Tension Load Based on Concrete or Bond (lb.)			
		ha	cac	ha	cac	Edge Distances = cac on all sides		Edge Distances = 1¼" on one side and cac on three sides	
						Uncracked	Cracked	Uncracked	Cracked
#3	2½	4¼	4	—	—	985	—	545	—
		5¾	3½	—	—			640	—
	3	4¾	5½	4¾	3½	1,245	500	515	325
		7¼	4½	—	—			710	
	4½	6¾	8½	6¾	3½	1,870	755	480	490
		10¾	6¾	—	—			710	
6	7¾	11¾	7¾	3½	2,490	1,005	465	650	
	14½	9	—	—			710		—
7½	9¾	15½	9¾	3½	3,110	1,255	455	815	
	18	11¼	—	—			710		—
#4	2¾	5¼	4½	—	—	1,475	—	845	—
		6¾	4½	—	—			845	—
	4	6½	7	6½	4½	2,145	1,805	780	1,030
		9¾	6	—	—			1,075	
	6	8½	11¾	8½	5½	3,220	2,705	725	1,455
		14½	9	—	—			1,075	
8	10½	15½	10½	6¾	4,295	3,605	700	1,805	
	19¼	12	—	—			1,075		—
10	12½	19¾	12½	7¾	5,370	4,510	685	2,140	
	24	15	—	—			1,075		—
#5	3½	6¼	5½	—	—	2,045	—	1,070	—
		7½	5½	—	—			1,070	—
	5	8½	8¾	8½	5½	3,270	2,545	1,085	1,330
		12	7½	—	—			1,505	
7½	10¾	14	10¾	6¾	4,900	3,815	1,010	1,885	
	18	11¼	—	—			1,505		—
12½	15½	24½	15½	9¾	8,170	6,355	955	2,860	
	30	18¾	—	—			1,505		—
#6	3½	7¼	6½	—	—	2,660	—	1,320	—
		8½	6½	—	—			1,320	—
	6	9¾	10¾	9¾	6½	4,560	3,255	1,430	1,615
		14½	9	—	—			1,975	
9	12¾	16½	12¾	8½	6,840	4,880	1,330	2,310	
	21¾	13½	—	—			1,975		—
15	18¾	29½	18¾	11¾	11,400	8,135	1,260	3,545	
	36	22½	—	—			1,975		—
#7	3¾	8½	7½	—	—	3,220	—	1,530	—
		9	7½	—	—			1,530	—
	7	11¾	11¾	11¾	7½	6,010	3,880	1,805	1,845
		16¾	10½	—	—			2,490	
10½	14¾	19½	14¾	9¾	9,015	5,820	1,680	2,670	
	25¼	15¾	—	—			2,490		—
17½	21¾	33½	21¾	12¾	15,025	9,695	1,590	4,120	
	42	26¼	—	—			2,490		—
#8	4	9	8¾	—	—	3,805	—	1,755	—
		9¾	8¾	—	—			1,755	—
	8	13	13¾	13	8¾	7,615	4,355	2,205	2,005
		19¼	12	—	—			3,045	
12	17	21½	17	9¾	11,420	6,530	2,050	2,905	
	28¾	18	—	—			3,045		—
20	25	37¾	25	13¾	19,030	10,885	1,945	4,555	
	48	30	—	—			3,045		—
#10	5	11¼	10½	—	—	5,545	—	—	—
		12	10½	—	—			—	—
	10	16¼	16¼	16¼	10¾	11,095	4,245	—	—
		24	15	—	—			—	
15	21¼	26½	21¼	10¾	16,640	6,365	—	—	
	36	22½	—	—			—		—
25	31¼	46	31¼	13½	27,730	10,605	—	—	
	60	37½	—	—			—		—

Rebar Size	Allowable Tension Load of Rebar Steel (lb.)	
	ASTM A615 GR 60	ASTM A706 GR 60
#3	4,595	4,085
#4	8,355	7,430
#5	12,955	11,515
#6	18,385	16,345
#7	25,070	22,285
#8	33,010	29,345
#10	52,930	47,170

1. Allowable tension load must be the lesser of the concrete, bond or rebar steel load.
2. Allowable tension loads are calculated based on the strength design provisions of ACI 318-11 Appendix D assuming dry concrete, periodic inspection, short-term temperature of 150°F and long-term temperature of 110°F. Tension design strengths are converted to allowable tension loads using a conversion factor of $\alpha = 1.4$. The conversion factor α is based on the load combination 1.2D + 1.6L assuming 50% dead load and 50% live load: $1.2(0.5) + 1.6(0.5) = 1.4$.
3. Tabulated values are for a single anchor with no influence of another anchor.
4. Interpolation between embedment depths is not permitted.

* See page 12 for an explanation of the load table icons.

SET-XP® Design Information — Concrete

SET-XP® Allowable Tension Loads for Rebar in Normal-Weight Concrete
($f'_c = 2,500$ psi) — Wind Load

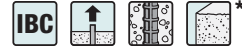

Adhesive Anchors

Rebar Size	Nominal Embed. Depth (in.)	Minimum Dimensions for Uncracked (in.)		Minimum Dimensions for Cracked (in.)		Allowable Tension Load Based on Concrete or Bond (lb.)			
		h_a	c_{ac}	h_a	c_{ac}	Edge Distances = c_{ac} on all sides		Edge Distances = $1\frac{1}{4}d$ on one side and c_{ac} on three sides	
						Uncracked	Cracked	Uncracked	Cracked
#3	2½	4¼	4	—	—	830	—	460	—
		5¾	3½	—	—		535	—	
	3	4¾	5½	4¾	3½	1,045	420	430	275
		7¼	4½	—	—			595	
	4½	6¾	8¾	6¾	3½	1,570	635	400	410
		10¾	6¾	—	—			595	
6	7¾	11¾	7¾	3½	2,090	845	390	545	
	14½	9	—	—			595		
7½	9¾	15½	9¾	3½	2,615	1,055	380	685	
	18	11¼	—	—			595		
#4	2¾	5¼	4½	—	—	1,240	—	710	—
		6¾	4½	—	—		710	—	
	4	6½	7	6½	4½	1,805	1,515	655	865
		9¾	6	—	—			905	
	6	8½	11¾	8½	5½	2,705	2,275	610	1,220
		14½	9	—	—			905	
8	10½	15½	10½	6¾	3,610	3,030	590	1,515	
	19¼	12	—	—			905		
10	12½	19¾	12½	7¾	4,510	3,790	575	1,795	
	24	15	—	—			905		
#5	3½	6¼	5½	—	—	1,715	—	900	—
		7½	5½	—	—		900	—	
	5	8½	8¾	8½	5½	2,745	2,135	910	1,120
		12	7½	—	—			1,265	
	7½	10¾	14	10¾	6¾	4,115	3,205	850	1,585
		18	11¼	—	—			1,265	
12½	15½	24¾	15½	9¾	6,860	5,335	805	2,405	
	30	18¾	—	—			1,265		
#6	3½	7¼	6½	—	—	2,235	—	1,105	—
		8½	6½	—	—		1,105	—	
	6	9¾	10¾	9¾	6½	3,830	2,735	1,200	1,355
		14½	9	—	—			1,660	
	9	12¾	16¾	12¾	8½	5,745	4,100	1,115	1,940
		21¾	13½	—	—			1,660	
15	18¾	29½	18¾	11¾	9,575	6,835	1,060	2,980	
	36	22½	—	—			1,660		
#7	3¾	8½	7½	—	—	2,705	—	1,285	—
		9	7½	—	—		1,285	—	
	7	11¾	11¾	11¾	7½	5,050	3,260	1,515	1,550
		16¾	10½	—	—			2,090	
	10½	14¾	19½	14¾	9½	7,570	4,885	1,410	2,245
		25¼	15¾	—	—			2,090	
17½	21¾	33½	21¾	12¾	12,620	8,145	1,335	3,460	
	42	26¼	—	—			2,090		
#8	4	9	8¾	—	—	3,200	—	1,475	—
		9¾	8¾	—	—		1,475	—	
	8	13	13¾	13	8¾	6,395	3,655	1,850	1,685
		19¼	12	—	—			2,560	
	12	17	21½	17	9¾	9,590	5,485	1,720	2,440
		28¾	18	—	—			2,560	
20	25	37¾	25	13¾	15,985	9,145	1,630	3,830	
	48	30	—	—			2,560		
#10	5	11¼	10½	—	—	4,660	—	—	—
		12	10½	—	—		—	—	
	10	16¼	16¼	16¼	10½	9,320	3,565	—	—
		24	15	—	—			—	
	15	21¼	26½	21¼	10½	13,975	5,345	—	—
		36	22½	—	—			—	
25	31¼	46	31¼	13½	23,295	8,910	—	—	
	60	37½	—	—			—		

Rebar Size	Allowable Tension Load of Rebar Steel (lb.)	
	ASTM A615 GR 60	ASTM A706 GR 60
#3	3,860	3,430
#4	7,020	6,240
#5	10,880	9,670
#6	15,445	13,730
#7	21,060	18,720
#8	27,730	24,650
#10	44,460	39,625

1. Allowable tension load must be the lesser of the concrete, bond or rebar steel load.
2. Allowable tension loads are calculated based on the strength design provisions of ACI 318-11 Appendix D assuming dry concrete, periodic inspection, short-term temperature of 150°F and long-term temperature of 110°F. Tension design strengths are converted to allowable tension loads using α conversion factor of $\alpha = \frac{1}{1.67}$. The conversion factor α is based on the load combination assuming 100% wind load.
3. Tabulated values are for a single anchor with no influence of another anchor.
4. Interpolation between embedment depths is not permitted.

* See page 12 for an explanation of the load table icons.

SET-XP® Design Information — Concrete

SET-XP® Allowable Tension Loads for Rebar in Normal-Weight Concrete
(f_c = 2,500 psi) — Seismic Load

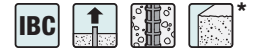

Rebar Size	Nominal Embed. Depth (in.)	Minimum Dimensions for Uncracked (in.)		Minimum Dimensions for Cracked (in.)		Allowable Tension Load Based on Concrete or Bond (lb.)							
		h _a	c _{ac}	h _a	c _{ac}	Edge Distances = c _{ac} on all sides				Edge Distances = 1¼" on one side and c _{ac} on three sides			
						SDC A-B ⁵		SDC C-F ^{6,7}		SDC A-B ⁵		SDC C-F ^{6,7}	
		Uncracked	Cracked	Uncracked	Cracked	Uncracked	Cracked	Uncracked	Cracked				
#3	2¾	4¼	4	—	—	965	—	725	—	535	—	405	—
		5¾	3¾	—	—	—	—	—	—	625	—	470	—
	3	4¾	5¾	4¾	3½	1,220	490	915	370	505	320	380	240
		7¼	4½	—	—	—	—	—	—	695	—	520	—
	4½	6¾	8¾	6¾	3½	1,830	740	1,370	555	470	480	355	355
		10¾	6¾	—	—	—	—	—	—	695	—	520	—
6	7¾	11¾	7¾	3½	2,440	985	1,830	740	455	635	340	480	
	14½	9	—	—	—	—	—	—	695	—	520	—	
7½	9¾	15¾	9¾	3½	3,050	1,230	2,285	920	445	800	335	600	
	18	11¼	—	—	—	—	—	—	695	—	520	—	
#4	2¾	5¼	4½	—	—	1,445	—	1,085	—	825	—	620	—
		6¾	4½	—	—	—	—	—	—	825	—	620	—
	4	6½	7	6½	4½	2,105	1,770	1,580	1,325	765	1,010	570	755
		9¾	6	—	—	—	—	—	—	1,055	—	790	—
	6	8½	11¾	8½	5½	3,155	2,655	2,365	1,990	710	1,425	530	1,070
		14½	9	—	—	—	—	—	—	1,055	—	790	—
8	10½	15¾	10½	6¾	4,210	3,535	3,155	2,655	685	1,770	515	1,325	
	19¼	12	—	—	—	—	—	—	1,055	—	790	—	
10	12½	19¾	12½	7¾	5,260	4,420	3,945	3,315	670	2,095	505	1,570	
	24	15	—	—	—	—	—	—	1,055	—	790	—	
#5	3¾	6¼	5½	—	—	2,000	—	1,500	—	1,050	—	790	—
		7½	5½	—	—	—	—	—	—	1,050	—	790	—
	5	8½	8¾	8½	5½	3,205	2,490	2,400	1,870	1,065	1,305	800	980
		12	7½	—	—	—	—	—	—	1,475	—	1,105	—
7½	10¾	14	10¾	6¾	4,800	3,740	3,600	2,805	990	1,850	740	1,385	
	18	11¼	—	—	—	—	—	—	1,475	—	1,105	—	
12½	15¾	24¾	15¾	9¾	8,005	6,225	6,005	4,670	940	2,805	705	2,105	
	30	18¾	—	—	—	—	—	—	1,475	—	1,105	—	
#6	3½	7¼	6½	—	—	2,610	—	1,955	—	1,290	—	970	—
		8½	6½	—	—	—	—	—	—	1,290	—	970	—
	6	9¾	10¾	9¾	6½	4,470	3,190	3,355	2,390	1,400	1,580	1,050	1,185
		14½	9	—	—	—	—	—	—	1,935	—	1,455	—
9	12¾	16¾	12¾	8¾	6,705	4,785	5,025	3,590	1,300	2,265	975	1,700	
	21½	13½	—	—	—	—	—	—	1,935	—	1,455	—	
15	18¾	29½	18¾	11¾	11,170	7,975	8,380	5,980	1,235	3,475	930	2,610	
	36	22½	—	—	—	—	—	—	1,935	—	1,455	—	
#7	3¾	8½	7½	—	—	3,155	—	2,365	—	1,500	—	1,125	—
		9	7½	—	—	—	—	—	—	1,500	—	1,125	—
	7	11¾	11¾	11¾	7½	5,890	3,800	4,415	2,850	1,770	1,810	1,325	1,360
		16¾	10½	—	—	—	—	—	—	2,440	—	1,830	—
10½	14¾	19½	14¾	9¾	8,835	5,700	6,625	4,275	1,645	2,620	1,230	1,965	
	25¼	15¾	—	—	—	—	—	—	2,440	—	1,830	—	
17½	21¾	33½	21¾	12¾	14,725	9,505	11,045	7,125	1,560	4,040	1,170	3,030	
	42	26¼	—	—	—	—	—	—	2,440	—	1,830	—	
#8	4	9	8¾	—	—	3,730	—	2,795	—	1,720	—	1,290	—
		9¾	8¾	—	—	—	—	—	—	1,720	—	1,290	—
	8	13	13¾	13	8¾	7,460	4,265	5,595	3,200	2,160	1,965	1,620	1,475
		19¼	12	—	—	—	—	—	—	2,985	—	2,240	—
12	17	21½	17	9¾	11,190	6,400	8,395	4,800	2,010	2,850	1,510	2,140	
	28¾	18	—	—	—	—	—	—	2,985	—	2,240	—	
20	25	37¾	25	13¾	18,650	10,670	13,990	8,000	1,905	4,465	1,430	3,350	
	48	30	—	—	—	—	—	—	2,985	—	2,240	—	
#10	5	11¼	10½	—	—	5,435	—	4,080	—	—	—	—	—
		12	10½	—	—	—	—	—	—	—	—	—	—
	10	16¼	16¼	16¼	10½	10,870	4,160	8,150	3,120	—	—	—	—
		24	15	—	—	—	—	—	—	—	—	—	—
15	21¼	26½	21¼	10½	16,305	6,235	12,230	4,675	—	—	—	—	
	36	22½	—	—	—	—	—	—	—	—	—	—	
25	31¼	46	31¼	13½	27,180	10,395	20,380	7,795	—	—	—	—	
	60	37½	—	—	—	—	—	—	—	—	—	—	

Rebar Size	Allowable Tension Load of Rebar Steel (lb.)	
	ASTM A615 GR 60	ASTM A706 GR 60
#3	4,505	4,005
#4	8,190	7,280
#5	12,695	11,285
#6	18,020	16,015
#7	24,570	21,840
#8	32,350	28,755
#10	51,870	46,230

1. Allowable tension load must be the lesser of the concrete, bond or rebar steel load.
2. Allowable tension loads are calculated based on the strength design provisions of ACI 318-11 Appendix D assuming dry concrete, periodic inspection, short-term temperature of 150°F and long-term temperature of 110°F. Tension design strengths are converted to allowable tension loads using α conversion factor of $\alpha = 1/1.43 = 0.7$. The conversion factor α is based on the load combination assuming 100% seismic load.
3. Tabulated values are for a single anchor with no influence of another anchor.
4. Interpolation between embedment depths is not permitted.
5. The allowable tension load listed for SDC (Seismic Design Category) A-B may also be used in SDC C-F when the tension component of the strength-level seismic design load on the anchor does not exceed 20% of the total factored tension load on the anchor associated with the same load combination.
6. When designing anchorages in SDC C-F, the Designer shall consider the ductility requirements of ACI 318-11 Section D.3.3.
7. Allowable tension loads in SDC C-F have been adjusted by 0.75 factor in accordance with ACI 318-11 Section D.3.3.4.4.

* See page 12 for an explanation of the load table icons.

Adhesive Anchors

SET-XP® Design Information — Masonry

SET-XP® Allowable Tension and Shear Loads for Threaded Rod and Rebar in the Face of Fully Grouted CMU Wall Construction ^{1, 3, 4, 5, 6, 8, 9, 10, 11}

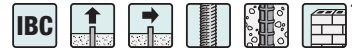

Adhesive Anchors

Diameter (in.) or Rebar Size No.	Drill Bit Diameter (in.)	Minimum Embedment ² (in.)	Allowable Load Based on Bond Strength ⁷ (lb.)	
			Tension Load	Shear Load
Threaded Rod Installed in the Face of CMU Wall				
3/8	1/2	3 3/8	1,490	1,145
1/2	5/8	4 1/2	1,825	1,350
5/8	3/4	5 5/8	1,895	1,350
3/4	7/8	6 1/2	1,895	1,350
Rebar Installed in the Face of CMU Wall				
#3	1/2	3 3/8	1,395	1,460
#4	5/8	4 1/2	1,835	1,505
#5	3/4	5 5/8	2,185	1,505

- Allowable load shall be the lesser of the bond values shown in this table and steel values, shown on page 61.
- Embedment depth shall be measured from the outside face of masonry wall.
- Critical and minimum edge distance and spacing shall comply with the information on page 55. Figure 2 on page 55 illustrates critical and minimum edge and end distances.
- Minimum allowable nominal width of CMU wall shall be 8 inches. No more than one anchor shall be permitted per masonry cell.
- Anchors shall be permitted to be installed at any location in the face of the fully grouted masonry wall construction (cell, web, bed joint), except anchors shall not be installed within 1 1/2 inches of the head joint, as show in Figure 2 on page 55.
- Tabulated allowable load values are for anchors installed in fully grouted masonry walls.
- Tabulated allowable loads are based on a safety factor of 5.0 .
- Tabulated allowable load values shall be adjusted for increased base material temperatures in accordance with Figure 1 below, as applicable.
- Threaded rod and rebar installed in fully grouted masonry walls are permitted to resist dead, live, seismic and wind loads.
- Threaded rod shall meet or exceed the tensile strength of ASTM F1554, Grade 36 steel, which is 58,000 psi.
- For installations exposed to severe, moderate or negligible exterior weathering conditions, as defined in Figure 1 of ASTM C62, allowable tension loads shall be multiplied by 0.80.

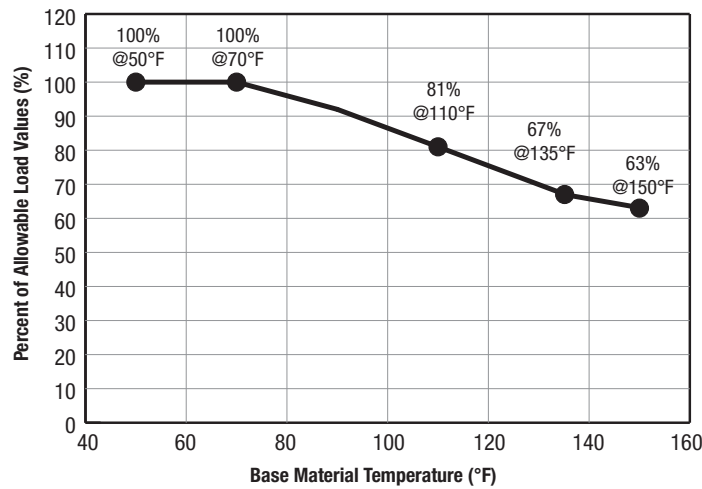
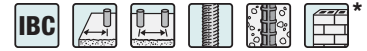

Figure 1. Load capacity based on in-service temperature for SET-XP® epoxy adhesive in the face of fully grouted CMU wall construction

* See page 12 for an explanation of the load table icons.

SET-XP® Design Information — Masonry

SET-XP® Edge Distance and Spacing Requirements and Allowable Load Reduction Factors – Threaded Rod and Rebar in the Face of Fully Grouted CMU Wall Construction⁷



Rod Dia. (in.) or Rebar Size No.	Minimum Embed. Depth (in.)	Edge or Edge Distance ^{1,8}						Spacing ^{2,9}				
		Critical (Full Anchor Capacity) ³		Minimum (Reduced Anchor Capacity) ⁴				Critical (Full Anchor Capacity) ⁵		Minimum (Reduced Anchor Capacity) ⁶		
		Critical Edge or End Distance, C_{cr} (in.)	Allowable Load Reduction Factor	Minimum Edge or End Distance, C_{min} (in.)	Allowable Load Reduction Factor		Critical Spacing, S_{cr} (in.)	Allowable Load Reduction Factor	Minimum Spacing, S_{min} (in.)	Allowable Load Reduction Factor		
					Tension or Shear	Tension				Tension or Shear	Tension	Shear
		Load Direction		Load Direction				Load Direction		Load Direction		
Tension or Shear	Tension or Shear	Tension or Shear	Tension	Shear ¹⁰	Tension or Shear	Tension or Shear	Tension or Shear	Tension	Shear			
				Perp.	Para.							
3/8	3%	12	1.00	4	0.91	0.72	0.94	8	1.00	4	1.00	1.00
1/2	4 1/2	12	1.00	4	1.00	0.58	0.87	8	1.00	4	0.82	1.00
5/8	5%	12	1.00	4	1.00	0.48	0.87	8	1.00	4	0.82	1.00
3/4	6 1/2	12	1.00	4	1.00	0.44	0.85	8	1.00	4	0.82	1.00
#3	3%	12	1.00	4	0.96	0.62	0.84	8	1.00	4	0.87	0.91
#4	4 1/2	12	1.00	4	0.88	0.54	0.82	8	1.00	4	0.87	0.91
#5	5%	12	1.00	4	0.88	0.43	0.82	8	1.00	4	0.87	1.00

- Edge distance (C_{cr} or C_{min}) is the distance measured from anchor centerline to edge or end of CMU masonry wall. Refer to Figure 2 below for an illustration showing critical and minimum edge and end distances.
- Anchor spacing (S_{cr} or S_{min}) is the distance measured from centerline to centerline of two anchors.
- Critical edge distance, C_{cr} , is the least edge distance at which tabulated allowable load of an anchor is achieved where a load reduction factor equals 1.0 (no load reduction).
- Minimum edge distance, C_{min} , is the least edge distance where an anchor has an allowable load capacity which shall be determined by multiplying the allowable loads assigned to anchors installed at critical edge distance, C_{cr} , by the load reduction factors shown above.
- Critical spacing, S_{cr} , is the least anchor spacing at which tabulated allowable load of an anchor is achieved such that anchor performance is not influenced by adjacent anchors.
- Minimum spacing, S_{min} , is the least spacing where an anchor has an allowable load capacity, which shall be determined by multiplying the allowable loads assigned to anchors installed at critical spacing distance, S_{cr} , by the load reduction factors shown above.
- Reduction factors are cumulative. Multiple reduction factors for more than one spacing or edge or end distance shall be calculated separately and multiplied.
- Load reduction factor for anchors loaded in tension or shear with edge distances between critical and minimum shall be obtained by linear interpolation.
- Load reduction factor for anchors loaded in tension with spacing between critical and minimum shall be obtained by linear interpolation.
- Perpendicular shear loads act towards the edge or end. Parallel shear loads act parallel to the edge or end (see Figure 5 on page 57). Perpendicular and parallel shear load reduction factors are cumulative when the anchor is located between the critical minimum edge and end distance.

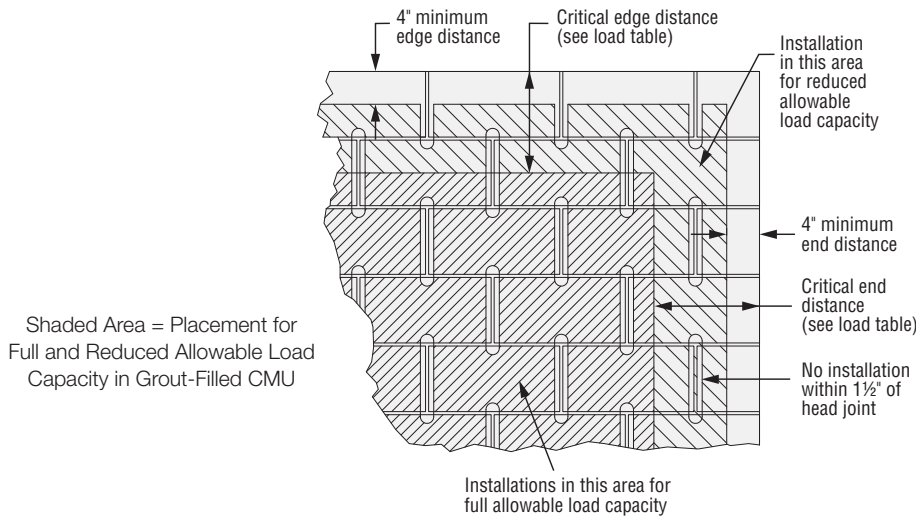
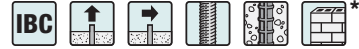

Figure 2. Allowable anchor locations for full and reduced load capacity when installation is in the face of fully grouted CMU masonry wall construction

* See page 12 for an explanation of the load table icons.

SET-XP® Design Information — Masonry

SET-XP® Allowable Tension and Shear Loads for Threaded Rod and Rebar in the Top of Fully Grouted CMU Wall Construction^{1, 2, 4, 5, 6, 7, 9, 10, 11, 12}



Diameter (in.) or Rebar Size No.	Drill Bit Diameter (in.)	Minimum Embedment ³ (in.)	Allowable Load Based on Bond Strength ^{7, 8} (lb.)		
			Tension Load	Shear Perp.	Shear Parallel
Threaded Rod Installed in the Top of CMU Wall					
1/2	5/8	4 1/2	1,485	590	1,050
		12	2,440	665	1,625
5/8	3/4	5 5/8	1,700	565	1,435
		15	2,960	660	1,785
3/4	7/8	6 1/2	1,610	735	1,370
		21	4,760	670	1,375
Rebar Installed in the Top of CMU Wall					
#4	5/8	4 1/2	1,265	550	865
		12	2,715	465	1,280
#5	3/4	5 5/8	1,345	590	1,140
		15	3,090	590	1,285

1. Allowable load shall be the lesser of the bond values shown in this table and steel values, shown on page 61.
2. Allowable loads are for installation in the grouted CMU core opening.
3. Embedment depth shall be measured from the horizontal surface of the grouted CMU core opening on top of the masonry wall.
4. Critical and minimum edge distance, end distance and spacing shall comply with the information on pages 57 and 58. Figures 3A and 3B on page 57 illustrate critical and minimum edge and end distances.
5. Minimum allowable nominal width of CMU wall shall be 8 inches (203 mm).
6. Anchors are permitted to be installed in the CMU core opening shown in Figures 3A and 3B on page 57. Anchors are limited to one installation per CMU core opening.
7. Tabulated allowable load values are for anchors installed in fully grouted masonry walls.
8. Tabulated allowable loads are based on a safety factor of 5.0.
9. Tabulated allowable load values shall be adjusted for increased base material temperatures in accordance with Figure 1 on page 54, as applicable.
10. Threaded rod and rebar installed in fully grouted masonry walls with SET-XP® adhesive are permitted to resist dead, live, seismic and wind loads.
11. Threaded rod shall meet or exceed the tensile strength of ASTM F1554, Grade 36 steel, which is 58,000 psi.
12. For installations exposed to severe, moderate or negligible exterior weathering conditions, as defined in Figure 1 of ASTM C62, allowable tension loads shall be multiplied by 0.80.

* See page 12 for an explanation of the load table icons.

SET-XP® Design Information — Masonry

SET-XP® Edge and End Distance Requirements and Allowable Load Reduction Factors — Threaded Rod and Rebar in the Top of Fully Grouted CMU Wall Construction^{1,4,5}



Rod Dia. (in.) or Rebar Size No.	Minimum Embed. Depth (in.)	Critical (Full Anchor Capacity) ²			Minimum End (Reduced Anchor Capacity) ³				Minimum Edge (Reduced Anchor Capacity) ⁶			
		Critical Edge, C_{cr} (in.)	Critical End Distance, C_{cr} (in.)	Allowable Load Reduction Factor	Minimum End Distance, C_{min} (in.)	Min. End Allowable Load Reduction Factor			Minimum Edge, C_{min} (in.)	Allowable Load Reduction Factor		
						Load Direction				Load Direction		
		Tension or Shear	Tension or Shear	Tension or Shear	Tension or Shear	Tension	Shear ⁶		Tension or Shear	Tension	Shear ⁶	
						Perp.	Parallel			Perp.	Parallel	
1/2	4 1/2	2 3/4	20	1.00	3 13/16	0.88	0.84	0.66	1 3/4	0.83	0.63	0.77
	12	2 3/4	20	1.00	3 13/16	0.64	0.91	0.34	1 3/4	0.95	0.55	0.69
5/8	5 5/8	2 3/4	20	1.00	4 1/4	0.90	1.00	0.50	1 3/4	0.82	0.57	0.71
	15	2 3/4	20	1.00	4 1/4	0.38	0.85	0.29	1 3/4	0.91	0.72	0.73
7/8	7 7/8	2 3/4	20	1.00	4 1/4	0.98	0.72	0.57	—	—	—	—
	21	2 3/4	20	1.00	4 1/4	0.63	0.96	0.64	—	—	—	—
#4	4 1/2	2 3/4	20	1.00	4 1/4	0.96	0.90	0.76	—	—	—	—
	12	2 3/4	20	1.00	4 1/4	0.58	1.00	0.46	—	—	—	—
#5	5 5/8	2 3/4	20	1.00	4 1/4	1.00	0.86	0.60	—	—	—	—
	15	2 3/4	20	1.00	4 1/4	0.41	0.76	0.49	—	—	—	—

Adhesive Anchors

1. Edge and end distances (C_{cr} or C_{min}) are the distances measured from anchor centerline to edge or end of CMU masonry wall. Refer to Figures 3A and 3B below for illustrations showing critical and minimum edge and end distances.
2. Critical edge and end distances, C_{cr} , are the least edge distances at which tabulated allowable load of an anchor is achieved where a load reduction factor equals 1.0 (no load reduction).
3. Minimum edge and end distances, C_{min} , are the least edge distances where an anchor has an allowable load capacity, which shall be determined by multiplying the allowable loads assigned to anchors installed at critical edge distance, C_{cr} , by the load reduction factors shown above.
4. Reduction factors are cumulative. Multiple reduction factors for more than one spacing or edge or end distance shall be calculated separately and multiplied.
5. Load reduction factor for anchors loaded in tension or shear with edge distances between critical and minimum shall be obtained by linear interpolation.
6. Perpendicular shear loads act towards the edge or end. Parallel shear loads act parallel to the edge or end (see Figure 5 below). Perpendicular and parallel shear load reduction factors are cumulative when the anchor is located between the critical minimum edge and end distance.

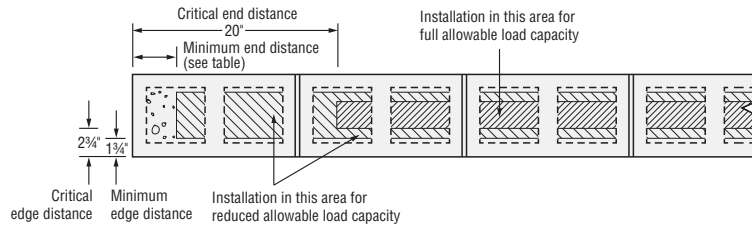

Figure 3A. Allowable anchor locations of 1/2"- and 5/8"-diameter threaded rod for full and reduced load capacity when installation is in the top of fully grouted CMU masonry wall construction

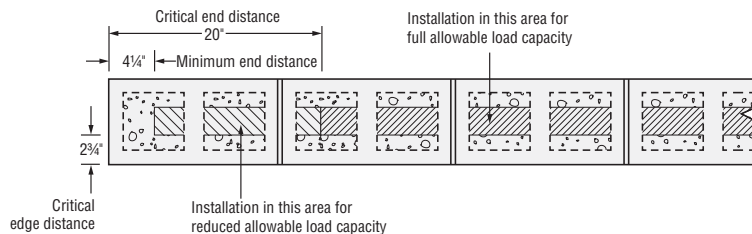
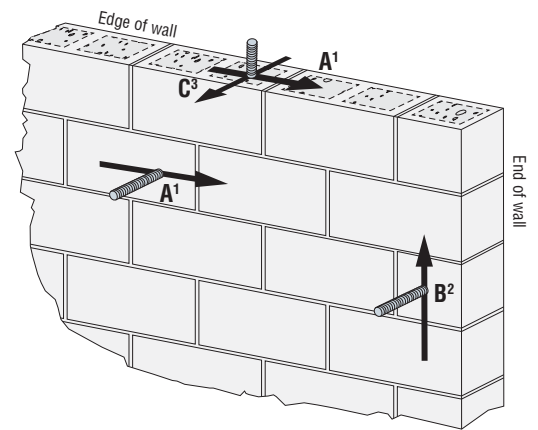

Figure 3B. Allowable anchor locations of 7/8"-diameter threaded rod and #4 and #5 rebar for full and reduced load capacity when installation is in the top of fully grouted CMU masonry wall construction



1. Direction of shear load A is parallel to edge of wall and perpendicular to end of wall.
2. Direction of shear load B is parallel to end of wall and perpendicular to edge of wall.
3. Direction of shear load C is perpendicular to edge of wall.

Figure 5. Direction of shear load in relation to edge and end of wall

* See page 12 for an explanation of the load table icons.

SET-XP® Design Information — Masonry

SET-XP® Spacing Distance Requirements and Allowable Load Reduction Factors — Threaded Rod and Rebar in the Top of Fully Grouted CMU Wall Construction^{1,4,5}



Adhesive Anchors

Rod Dia. (in.) or Rebar Size No.	Minimum Embed. Depth (in.)	Critical Spacing (Full Anchor Capacity) ²		Minimum Spacing (Reduced Anchor Capacity) ³		
		Critical Spacing, S_{cr} (in.)	Allowable Load Reduction Factor	Minimum Spacing, S_{cr} (in.)	Allowable Load Reduction Factor	
					Load Direction	
		Tension or Shear	Tension or Shear	Tension or Shear	Tension	Shear
½	4½	18	1.00	8	0.80	0.92
	12	48	1.00	8	0.63	0.98
⅝	5⅝	22.5	1.00	8	0.86	1.00
	15	60	1.00	8	0.56	1.00
⅞	7⅞	31.5	1.00	8	0.84	0.82
	21	84	1.00	8	0.51	0.98
#4	4½	18	1.00	8	0.97	0.93
	12	48	1.00	8	0.75	1.00
#5	5⅝	22.5	1.00	8	1.00	1.00
	15	60	1.00	8	0.82	1.00

1. Anchor spacing (S_{cr} or S_{min}) is the distance measured from centerline to centerline of two anchors.

2. Critical spacing, S_{cr} , is the least anchor spacing at which tabulated allowable load of an anchor is achieved such that anchor performance is not influenced by adjacent anchors.

3. Minimum spacing, S_{min} , is the least spacing where an anchor has an allowable load capacity, which shall be determined by multiplying the allowable loads assigned to anchors installed at critical spacing distance, S_{cr} , by the load reduction factors shown above.

4. Reduction factors are cumulative. Multiple reduction factors for more than one spacing or edge or end distance shall be calculated separately and multiplied.

5. Load reduction factor for anchors loaded in tension or shear with edge distances between critical and minimum shall be obtained by linear interpolation.

* See page 12 for an explanation of the load table icons.

SET-XP® Design Information — Masonry

SET-XP® Allowable Tension and Shear Loads – Threaded Rod in the Face of Hollow CMU Wall Construction^{1,3,4,5,6,8,9,10,11}



Diameter (in.)	Drill Bit Diameter (in.)	Minimum Embed ² (in.)	Allowable Load Based on Bond Strength ⁷ (lb.)	
			Tension	Shear
3/8	9/16	1 1/4	245	415
1/2	3/4	1 1/4	245	505
5/8	7/8	1 1/4	290	530

1. Allowable load shall be the lesser of bond values shown in this table and steel values shown on page 61.
2. Embedment depth is considered the minimum wall thickness of 8" x 8" x 16" ASTM C90 concrete masonry blocks, and is measured from the outside to the inside face of the block wall. The minimum length Opti-Mesh plastic screen tube for use in hollow CMU is 3 1/2".
3. Critical and minimum edge distance and spacing shall comply with the information provided on page 60. Figure 4 on page 60 illustrates critical and minimum edge and end distances.
4. Anchors are permitted to be installed in the face shell of hollow masonry wall construction as shown in Figure 4.
5. Anchors are limited to one or two anchors per masonry cell and must comply with the spacing and edge distance requirements provided.
6. Tabulated load values are for anchors installed in hollow masonry walls.
7. Tabulated allowable loads are based on a safety factor of 5.0.
8. Tabulated allowable load values shall be adjusted for increased base material temperatures in accordance with Figure 1 on page 54, as applicable.
9. Threaded rods installed in hollow masonry walls with SET-XP® adhesive are permitted to resist dead, live load and wind load applications.
10. Threaded rods must meet or exceed the tensile strength of ASTM F1554, Grade 36, which is 58,000 psi.
11. For installations exposed to severe, moderate or negligible exterior weathering conditions, as defined in Figure 1 of ASTM C62, allowable tension loads must be multiplied by 0.80.

* See page 12 for an explanation of the load table icons.

SET-XP® Design Information — Masonry

SET-XP® Edge, End and Spacing Distance Requirements and Allowable Load Reduction Factors — Threaded Rod in the Face of Hollow CMU Wall Construction⁷

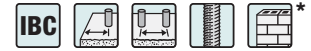

Adhesive Anchors

Rod Diameter (in.)	Edge or End Distance ^{1,8}					Spacing ^{2,9}				
	Critical (Full Anchor Capacity) ³		Minimum (Reduced Anchor Capacity) ⁴			Critical (Full Anchor Capacity) ⁵		Minimum (Reduced Anchor Capacity) ⁶		
	Critical Edge or End Distance, C_{cr} (in.)	Allowable Load Reduction Factor	Minimum Edge or End Distance, C_{min} (in.)	Allowable Load Reduction Factor		Critical Spacing, S_{cr} (in.)	Allowable Load Reduction Factor	Minimum Spacing, S_{min} (in.)	Allowable Load Reduction Factor	
	Load Direction		Load Direction			Load Direction		Load Direction		
Tension or Shear	Tension or Shear	Tension or Shear	Tension	Shear ¹⁰	Tension or Shear	Tension or Shear	Tension or Shear	Tension	Shear	
3/8	12	1.00	4	0.71	0.57	8	1.00	4	0.56	0.92
1/2	12	1.00	4	0.73	0.51	8	1.00	4	0.61	0.85
5/8	12	1.00	4	0.66	0.49	8	1.00	4	0.65	0.76

- Edge and end distances (C_{cr} or C_{min}) are the distances measured from anchor centerline to edge or end of CMU masonry wall. Refer to Figure 4 below for an illustration showing critical and minimum edge and end distances.
- Anchor spacing (S_{cr} or S_{min}) is the distance measured from centerline to centerline of two anchors.
- Critical edge and end distances, C_{cr} , are the least edge distances at which tabulated allowable load of an anchor is achieved where a load reduction factor equals 1.0 (no load reduction).
- Minimum edge and end distances, C_{min} , are the least edge distances where an anchor has an allowable load capacity which shall be determined by multiplying the allowable loads assigned to anchors installed at critical edge distance, C_{cr} , by the load reduction factors shown above.
- Critical spacing, S_{cr} , is the least anchor spacing at which tabulated allowable load of an anchor is achieved such that anchor performance is not influenced by adjacent anchors.
- Minimum spacing, S_{min} , is the least spacing where an anchor has an allowable load capacity, which shall be determined by multiplying the allowable loads assigned to anchors installed at critical spacing distance, S_{cr} , by the load reduction factors shown above.
- Reduction factors are cumulative. Multiple reduction factors for more than one spacing or edge or end distance shall be calculated separately and multiplied.
- Load reduction factor for anchors loaded in tension or shear with edge distances between critical and minimum shall be obtained by linear interpolation.
- Load reduction factor for anchors loaded in tension with spacing between critical and minimum shall be obtained by linear interpolation.
- Perpendicular shear loads act toward the edge or end. Parallel shear loads act parallel to the edge or end (see Figure 5 on page 57). Perpendicular and parallel shear load reduction factors are cumulative when the anchor is located between the critical minimum edge and end distance.

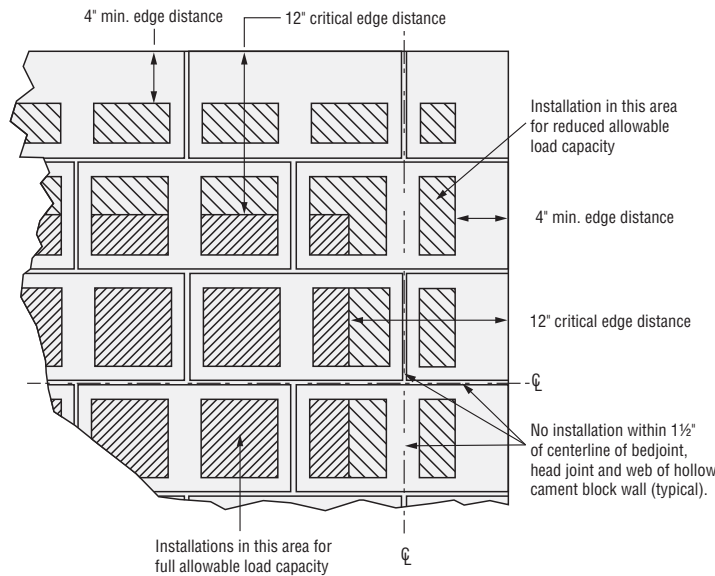
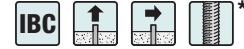

Figure 4. Allowable anchor locations for full and reduced load capacity when installation is in the face of hollow CMU masonry wall construction

* See page 12 for an explanation of the load table icons.

SET-XP® Design Information — Masonry

SET-XP® Allowable Tension and Shear Loads —
Threaded Rod Based on Steel Strength¹

Threaded Rod Diameter (in.)	Tensile Stress Area (in. ²)	Tension Load Based on Steel Strength ² (lb.)				Shear Load Based on Steel Strength ³ (lb.)			
		ASTM F1554 Grade 36 ⁴	ASTM A193 Grade B7 ⁶	Stainless Steel		ASTM F1554 Grade 36 ⁴	ASTM A193 Grade B7 ⁶	Stainless Steel	
				ASTM A193 Grade B6 ⁵	ASTM A193 Grades B8 and B8M ⁷			ASTM A193 Grade B6 ⁵	ASTM A193 Grades B8 and B8M ⁷
3/8	0.078	1,495	3,220	2,830	1,930	770	1,660	1,460	995
1/2	0.142	2,720	5,860	5,155	3,515	1,400	3,020	2,655	1,810
5/8	0.226	4,325	9,325	8,205	5,595	2,230	4,805	4,225	2,880
3/4	0.334	6,395	13,780	12,125	8,265	3,295	7,100	6,245	4,260
7/8	0.462	8,845	19,055	16,770	11,435	4,555	9,815	8,640	5,890

1. Allowable load shall be the lesser of bond values given on pages 54, 56 or 59 and steel values in the table above.
2. Allowable Tension Steel Strength is based on the following equation: $F_v = 0.33 \times F_u \times \text{Tensile Stress Area}$.
3. Allowable Shear Steel Strength is based on the following equation: $F_v = 0.17 \times F_u \times \text{Tensile Stress Area}$.
4. Minimum specified tensile strength ($F_u = 58,000$ psi) of ASTM F1554, Grade 36 used to calculate allowable steel strength.
5. Minimum specified tensile strength ($F_u = 110,000$ psi) of ASTM A193, Grade B6 used to calculate allowable steel strength.
6. Minimum specified tensile strength ($F_u = 125,000$ psi) of ASTM A193, Grade B7 used to calculate allowable steel strength.
7. Minimum specified tensile strength ($F_u = 75,000$ psi) of ASTM A193, Grades B8 and B8M used to calculate allowable steel strength.

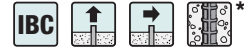
SET-XP® Allowable Tension and Shear Loads —
Deformed Reinforcing Bar Based on Steel Strength¹

Rebar Size	Tensile Stress Area (in. ²)	Tension Load (lb.)		Shear Load (lb.)	
		Based on Steel Strength		Based on Steel Strength	
		ASTM A615 Grade 40 ²	ASTM A615 Grade 60 ³	ASTM A615 Grade 40 ^{4,5}	ASTM A615 Grade 60 ^{4,5}
#3	0.11	2,200	2,640	1,310	1,685
#4	0.20	4,000	4,800	2,380	3,060
#5	0.31	6,200	7,400	3,690	4,745

1. Allowable load shall be the lesser of bond values given on pages 54, 56 or 59 and steel values in the table above.
2. Allowable Tension Steel Strength is based on AC58 Section 3.3.3 (20,000 psi x tensile stress area) for Grade 40 rebar.
3. Allowable Tension Steel Strength is based on AC58 Section 3.3.3 (24,000 psi x tensile stress area) for Grade 60 rebar.
4. Allowable Shear Steel Strength is based on AC58 Section 3.3.3 ($F_v = 0.17 \times F_u \times \text{Tensile Stress Area}$.)
5. $F_u = 70,000$ psi for Grade 40 rebar.
6. $F_u = 90,000$ psi for Grade 60 rebar.

* See page 12 for an explanation of the load table icons.

ET-HP® Epoxy Adhesive

ET-HP® is a two-component, high-solids, epoxy-based system for use as a high-strength, non-shrink anchor-grouting material. Resin and hardener are dispensed and mixed simultaneously through the mixing nozzle. ET-HP® is formulated for anchoring threaded rod and rebar into concrete (cracked/uncracked) and masonry.

Features

- Passed the demanding ICC-ES AC308 adverse-condition tests pertaining to elevated temperatures and long-term sustained loads
- Code listed under the IBC/IRC for cracked and uncracked concrete per ICC-ES ESR-3372
- Code listed under the IBC/IRC for masonry per IAPMO UES ER-241
- Suitable for use under static and seismic loading conditions in cracked and uncracked concrete and masonry
- Cure times: 24 hours at 80°F, 72 hours at 50°F
- Easy hole-cleaning – no power-brushing required
- Suitable for use in dry or water-saturated concrete
- When properly mixed, adhesive will be a uniform gray color
- Available in 22 oz. and 56 oz. cartridges for application versatility
- Manufactured in the USA using global materials

Applications

- Threaded rod anchoring and rebar doweling into concrete and unreinforced masonry
- Suitable for horizontal, vertical and overhead applications
- Multiple DOT listings – refer to www.strongtie.com/DOT for current approvals

Codes: ICC-ES ESR-3372 (concrete); ICC-ES ESR-3638 (unreinforced masonry); IAPMO UES ER-241 (masonry); City of L.A. RR25120 (unreinforced masonry); AASHTO M-235 and ASTM C881 (Type IV, Grade 3, Class C); multiple DOT listings; FL-17449.1; FL-16230.2.

Chemical Resistance

See pages 320–321.

Installation and Application Instructions

(See also pages 124–127.)

- Surfaces to receive epoxy must be clean.
- Base material temperature must be 50°F or above at the time of installation. For best results, material should be 70°–80°F at time of application.
- To warm cold material, store cartridges in a warm, uniformly heated area or storage container. Do not immerse cartridges in water to facilitate warming.
- Mixed material in nozzle can harden in 30 minutes at temperatures of 70°F and above.



ET-HP® Adhesive

Design Example

See pages 324 and 328.

Suggested Specifications

See www.strongtie.com for more information.

ET-HP® Epoxy Adhesive

Test Criteria

Anchors installed with ET-HP® adhesive have been tested in accordance with ICC-ES Acceptance Criteria for Post-Installed *Adhesive Anchors in Masonry Elements (AC58)* and *Adhesive Anchors in Concrete Elements (AC308)*.

Property	Test Method	Result*
Consistency	ASTM C881	Non-sag/thixotropic paste
Heat deflection	ASTM D648	133°F (56°C)
Glass transition temperature	ASTM D648	168°F (76°C)
Bond strength (moist cure, 60°F)	ASTM C882	2,300 psi (2 days) 2,440 psi (14 days)
Water absorption	ASTM D570	0.34% (24 hours)
Compressive yield strength (cured 60°F)	ASTM D695	16,300 psi (7 days)
Compressive modulus	ASTM D695	595,500 psi (7 days)
Gel time	ASTM C881	10 minutes – 60 gram mass 30 minutes – thin film
Shore D Durometer	ASTM D2240	87
Volatile Organic Compound (VOC)	—	3 g/L

*Material and curing conditions: 73 ± 2°F unless otherwise noted.

ET-HP® Cartridge Systems

Model No.	Capacity ounces	Cartridge Type	Carton Quantity	Dispensing Tools	Mixing Nozzle
ET-HP22-N ⁴	22	Side-by-side	10	EDT22S EDTA22CKT EDTA22P	EMN22i
ET-HP22	22	Side-by-side	10		EMN22i
ET-HP56	56	Side-by-side	6	EDTA56P	EMN22i or EMN50

1. Cartridge estimation guidelines are available at www.strongtie.com/apps.
2. Detailed information on dispensing tools, mixing nozzles and other adhesive accessories is available on pages 128 through 135, or at www.strongtie.com.
3. Use only Simpson Strong-Tie® mixing nozzles in accordance with Simpson Strong-Tie instructions. Modification or improper use of mixing nozzle may impair ET-HP adhesive performance.
4. One EMN22i mixing nozzle and one nozzle extension are supplied with each cartridge.

Cure Schedule

Base Material Temperature		Cure Time
°F	°C	
50	10	72 hrs.
60	16	24 hrs.
80	27	24 hrs.
100	38	24 hrs.

For water-saturated concrete, the cure times must be doubled.

ET-HP® Design Information — Concrete

ET-HP® Installation Information and Additional Data for Threaded Rod and Rebar in Normal-Weight Concrete¹

Characteristic	Symbol	Units	Nominal Anchor Diameter (in.) / Rebar Size						
			3/8 / #3	1/2 / #4	5/8 / #5	3/4 / #6	7/8 / #7	1 / #8	1 1/4 / #10
Installation Information									
Drill Bit Diameter	d_{hole}	in.	1/2	5/8	3/4	7/8	1	1 1/8	1 3/8
Maximum Tightening Torque	T_{inst}	ft.-lb.	10	20	30	45	60	80	125
Permitted Embedment Depth Range	Minimum	h_{ef}	2 3/8	2 3/4	3 1/8	3 1/2	3 3/4	4	5
	Maximum	h_{ef}	4 1/2	6	7 1/2	9	10 1/2	12	15
Minimum Concrete Thickness	h_{min}	in.	$h_{ef} + 5d_o$						
Critical Edge Distance ²	c_{ac}	in.	See footnote 2						
Minimum Edge Distance	c_{min}	in.	1 3/4						2 3/4
Minimum Anchor Spacing	s_{min}	in.	3						6

1. The information presented in this table is to be used in conjunction with the design criteria of ACI 318-11.

2. $c_{ac} = h_{ef}(\tau_{k,uncr}/1160)^{0.4} \times [3.1 - 0.7(h/h_{ef})]$, where:

$$[h/h_{ef}] \leq 2.4$$

$\tau_{k,uncr}$ = the characteristic bond strength in uncracked concrete, given in the tables that follow $\leq k_{uncr}((h_{ef} \times f_c)^{0.5}/(T \times d_a))$

h = the member thickness (inches)

h_{ef} = the embedment depth (inches)

* See page 12 for an explanation of the load table icons.

ET-HP® Design Information — Concrete

ET-HP® Tension Strength Design Data for Threaded Rod in Normal-Weight Concrete¹

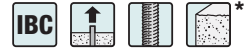

Characteristic		Symbol	Units	Nominal Anchor Diameter (in.)							
				3/8	1/2	5/8	3/4	7/8	1	1 1/4	
Steel Strength in Tension											
Threaded Rod	Minimum Tensile Stress Area	A_{se}	in. ²	0.078	0.142	0.226	0.334	0.462	0.606	0.969	
	Tension Resistance of Steel — ASTM F1554, Grade 36	N_{sa}	lb.	4,525	8,235	13,110	19,370	26,795	35,150	56,200	
	Tension Resistance of Steel — ASTM A193, Grade B7			9,750	17,750	28,250	41,750	57,750	75,750	121,125	
	Tension Resistance of Steel — Type 410 Stainless (ASTM A193, Grade B6)			8,580	15,620	24,860	36,740	50,820	66,660	106,590	
	Tension Resistance of Steel — Type 304 and 316 Stainless (ASTM A193, Grade B8 & B8M)			4,445	8,095	12,880	19,040	26,335	34,540	55,235	
	Strength Reduction Factor — Steel Failure			ϕ	—	0.75 ⁶					
Concrete Breakout Strength in Tension (2,500 psi ≤ f'_c ≤ 8,000 psi)¹²											
Effectiveness Factor — Uncracked Concrete		k_{uncr}	—	24							
Effectiveness Factor — Cracked Concrete		k_{cr}	—	17							
Strength Reduction Factor — Breakout Failure		ϕ	—	0.65 ⁸							
Bond Strength in Tension (2,500 psi ≤ f'_c ≤ 8,000 psi)¹²											
Uncracked Concrete ^{2,3,4}	Characteristic Bond Strength ^{5,13}	$\tau_{k,uncr}$	psi	390	380	370	360	350	335	315	
	Permitted Embedment Depth Range	Minimum	h_{ef}	in.	2 3/8	2 3/4	3 1/8	3 1/2	3 3/4	4	5
		Maximum	h_{ef}	in.	4 1/2	6	7 1/2	9	10 1/2	12	15
Cracked Concrete ^{2,3,4}	Characteristic Bond Strength ^{5,9,10,11,12,13}	$\tau_{k,cr}$	psi	160	200	160	205	190	165	140	
	Permitted Embedment Depth Range	Minimum	h_{ef}	in.	2 3/8	2 3/4	3 1/8	3 1/2	3 3/4	4	5
		Maximum	h_{ef}	in.	4 1/2	6	7 1/2	9	10 1/2	12	15
Bond Strength in Tension — Bond Strength Reduction Factors for Periodic Special Inspection											
Strength Reduction Factor — Dry Concrete		ϕ_{dry}	—	0.65 ⁷							
Strength Reduction Factor — Water-Saturated Concrete		ϕ_{sat}	—	0.45 ⁷							

- The information presented in this table is to be used in conjunction with the design criteria of ACI 318-11.
- Temperature Range: Maximum short-term temperature of 150°F (66°C). Maximum long-term temperature of 110°F (43°C).
- Short-term concrete temperatures are those that occur over short intervals (diurnal cycling).
- Long-term concrete temperatures are constant temperatures over a significant time period.
- For anchors that only resist wind or seismic loads, bond strengths may be multiplied by 2.70.
- The value of ϕ applies when the load combinations of ACI 318 Section 9.2 are used. If the load combinations of ACI 318 Appendix C are used, refer to Section D.4.5 to determine the appropriate value of ϕ .
- The value of ϕ applies when both the load combinations of ACI 318 Section 9.2 are used and the requirements of Section D.4.4 (c) for Condition B are met. If the load combinations of ACI 318 Appendix C are used, refer to Section D.4.5 to determine the appropriate value of ϕ .
- The value of ϕ applies when both the load combinations of ACI 318 Section 9.2 are used and the requirements of Section D.4.4 (c) for Condition B are met. If the load combinations of ACI 318 Section 9.2 are used and the requirements of Section D.4.4 (c) for Condition A are met, refer to Section D.4.4 to determine the appropriate value of ϕ . If the load combinations of ACI 318 Appendix C are used, refer to Section D.4.5 to determine the appropriate value of ϕ .
- For anchors installed in regions assigned to Seismic Design Category C, D, E or F, the bond strength values for 3/8" and 1/4" anchors must be multiplied by $\alpha_{N,seis} = 0.78$.
- For anchors installed in regions assigned to Seismic Design Category C, D, E or F, the bond strength values for 1/2", 5/8" and 3/4" anchors must be multiplied by $\alpha_{N,seis} = 0.85$.
- For anchors installed in regions assigned to Seismic Design Category C, D, E or F, the bond strength values for 7/8" anchors must be multiplied by $\alpha_{N,seis} = 0.82$.
- For anchors installed in regions assigned to Seismic Design Category C, D, E or F, the bond strength values for 1" anchors must be multiplied by $\alpha_{N,seis} = 0.70$.
- For applications where maximum short-term temperature is 110°F (43°C) and the maximum long-term temperature is 75°F (24°C), bond strengths may be multiplied by 3.50. No additional increase is permitted for anchors that only resist wind or seismic loads.

* See page 12 for an explanation of the load table icons.

ET-HP® Design Information — Concrete

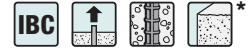
ET-HP® Tension Strength Design Data for Rebar in Normal-Weight Concrete¹

Characteristic		Symbol	Units	Rebar Size							
				#3	#4	#5	#6	#7	#8	#10	
Steel Strength in Tension											
Rebar	Minimum Tensile Stress Area	A_{se}	in ²	0.11	0.2	0.31	0.44	0.6	0.79	1.23	
	Tension Resistance of Steel — Rebar (ASTM A615 Grade 60)	N_{sa}	lb.	9,900	18,000	27,900	39,600	54,000	71,100	110,700	
	Strength Reduction Factor — Steel Failure	ϕ	—	0.65 ⁵							
Concrete Breakout Strength in Tension (2,500 psi ≤ f'_c ≤ 8,000 psi)											
Effectiveness Factor — Uncracked Concrete		k_{uncr}	—	24							
Effectiveness Factor — Cracked Concrete		k_{cr}	—	17							
Strength Reduction Factor — Breakout Failure		ϕ	—	0.65 ⁵							
Bond Strength in Tension (2,500 psi ≤ f'_c ≤ 8,000 psi)											
Uncracked Concrete ^{2,3,4}	Characteristic Bond Strength ^{5,9}		$\tau_{k,uncr}$	psi	370	360	350	335	325	315	295
	Permitted Embedment Depth Range	Minimum	h_{ef}	in.	2 $\frac{3}{8}$	2 $\frac{3}{4}$	3 $\frac{1}{8}$	3 $\frac{1}{2}$	3 $\frac{3}{4}$	4	5
		Maximum	h_{ef}	in.	4 $\frac{1}{2}$	6	7 $\frac{1}{2}$	9	10 $\frac{1}{2}$	12	15
Cracked Concrete ^{2,3,4}	Characteristic Bond Strength ^{5,9}		$\tau_{k,cr}$	psi	130	140	155	165	180	190	215
	Permitted Embedment Depth Range	Minimum	h_{ef}	in.	2 $\frac{3}{8}$	2 $\frac{3}{4}$	3 $\frac{1}{8}$	3 $\frac{1}{2}$	3 $\frac{3}{4}$	4	5
		Maximum	h_{ef}	in.	4 $\frac{1}{2}$	6	7 $\frac{1}{2}$	9	10 $\frac{1}{2}$	12	15
Bond Strength in Tension - Bond Strength Reduction Factors for Periodic and Continuous Special Inspection											
Strength Reduction Factor — Dry Concrete		ϕ_{dry}	—	0.65 ⁷							
Strength Reduction Factor — Water-saturated Concrete		ϕ_{sat}	—	0.45 ⁷							

1. The information presented in this table is to be used in conjunction with the design criteria of ACI 318-11.

2. Temperature Range: Maximum short-term temperature of 150°F (66°C). Maximum long-term temperature of 110°F (43°C).

3. Short-term concrete temperatures are those that occur over short intervals (diurnal cycling).

4. Long-term concrete temperatures are constant temperatures over a significant time period.

5. For anchors that only resist wind or seismic loads, bond strengths may be multiplied by 2.70.

6. The value of ϕ applies when the load combinations of ACI 318 Section 9.2 are used. If the load combinations of ACI 318 Appendix C are used, refer to Section D.4.5 to determine the appropriate value of ϕ .

7. The value of ϕ applies when both the load combinations of ACI 318 Section 9.2 are used and the requirements of Section D.4.4 (c) for Condition B are met. If the load combinations of ACI 318 Appendix C are used, refer to Section D.4.5 to determine the appropriate value of ϕ .

8. The value of ϕ applies when both the load combinations of ACI 318 Section 9.2 are used and the requirements of Section D.4.4 (c) for Condition B are met. If the load combinations of ACI 318 Section 9.2 are used and the requirements of Section D.4.4 (c) for Condition A are met, refer to Section D.4.4 to determine the appropriate value of ϕ . If the load combinations of ACI 318 Appendix C are used, refer to Section D.4.5 to determine the appropriate value of ϕ .

9. For applications where maximum short-term temperature is 110°F (43°C) and the maximum long-term temperature is 75°F (24°C), bond strengths may be multiplied by 3.50. No additional increase is permitted for anchors that only resist wind or seismic loads.

* See page 12 for an explanation of the load table icons.

ET-HP® Design Information — Concrete

ET-HP® Shear Strength Design Data for Threaded Rod in Normal-Weight Concrete¹



Characteristic		Symbol	Units	Nominal Anchor Diameter (in.)						
				3/8	1/2	5/8	3/4	7/8	1	1 1/4
Steel Strength in Shear										
Threaded Rod	Minimum Shear Stress Area	A_{se}	in. ²	0.078	0.142	0.226	0.334	0.462	0.606	0.969
	Shear Resistance of Steel — ASTM F1554, Grade 36	V_{sa}	lb.	2,260	4,940	7,865	11,625	16,080	21,090	33,720
	Shear Resistance of Steel — ASTM A193, Grade B7			4,875	10,650	16,950	25,050	34,650	45,450	72,675
	Shear Resistance of Steel — Type 410 Stainless (ASTM A193, Grade B6)			4,290	9,370	14,910	22,040	30,490	40,000	63,955
	Shear Resistance of Steel — Type 304 and 316 Stainless (ASTM A193, Grade B8 & B8M)			2,225	4,855	7,730	11,420	15,800	20,725	33,140
	Reduction for Seismic Shear — ASTM F1554, Grade 36	$\alpha_{V_{seis}}$	—	0.63		0.85		0.75		
	Reduction for Seismic Shear — ASTM A193, Grade B7			0.63		0.85		0.75		
	Reduction for Seismic Shear — Stainless (ASTM A193, Grade B6)			0.60		0.85		0.75		
	Reduction for Seismic Shear — Stainless (ASTM A193, Grade B8 & B8M)			0.60		0.85		0.75		
Strength Reduction Factor — Steel Failure	ϕ			—			0.65 ²			
Concrete Breakout Strength in Shear										
	Outside Diameter of Anchor	d_o	in.	0.375	0.5	0.625	0.75	0.875	1	1.25
	Load Bearing Length of Anchor in Shear	ℓ_e	in.	h_{ef}						
	Strength Reduction Factor — Breakout Failure	ϕ	—	0.70 ³						
Concrete Pryout Strength in Shear										
	Coefficient for Pryout Strength	k_{cp}	—	1.0 for $h_{ef} < 2.50"$; 2.0 for $h_{ef} \geq 2.50"$						
	Strength Reduction Factor — Pryout Failure	ϕ	—	0.70 ⁴						

- The information presented in this table is to be used in conjunction with the design criteria of ACI 318-11.
- The value of ϕ applies when the load combinations of ACI 318 Section 9.2 are used. If the load combinations of ACI 318 Appendix C are used, refer to Section D.4.4 to determine the appropriate value of ϕ .
- The value of ϕ applies when both the load combinations of ACI 318 Section 9.2 are used and the requirements of Section D.4.3 (c) for Condition B are met. If the load combinations of ACI 318 Section 9.2 are used and the requirements of Section D.4.3 (c) for Condition A are met, refer to Section D.4.3 to determine the appropriate value of ϕ . If the load combinations of ACI 318 Appendix C are used, refer to Section D.4.4 to determine the appropriate value of ϕ .
- The value of ϕ applies when both the load combinations of ACI 318 Section 9.2 are used and the requirements of Section D.4.3 (c) for Condition B are met. If the load combinations of ACI 318 Appendix C are used, refer to Section D.4.4 to determine the appropriate value of ϕ .
- The values of V_{sa} are applicable for both cracked concrete and uncracked concrete. For anchors installed in regions assigned to Seismic Design Category C, D, E or F, V_{sa} must be multiplied by $\alpha_{V_{seis}}$ for the corresponding anchor steel type.

Adhesive Anchors

* See page 12 for an explanation of the load table icons.

ET-HP® Design Information — Concrete

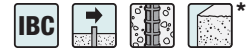

ET-HP® Shear Strength Design Data for Rebar in Normal-Weight Concrete¹

Characteristic	Symbol	Units	Rebar Size							
			#3	#4	#5	#6	#7	#8	#10	
Steel Strength in Shear										
Rebar	Minimum Shear Stress Area	A_{se}	in. ²	0.11	0.2	0.31	0.44	0.6	0.79	1.23
	Shear Resistance of Steel — Rebar (ASTM A615 Grade 60)	V_{sa}	lb.	4,950	10,800	16,740	23,760	32,400	42,660	66,420
	Reduction for Seismic Shear — Rebar (ASTM A615 Grade 60)	$\alpha_{V_{seis}}$ ⁵	—	0.6		0.8		0.75		
	Strength Reduction Factor — Steel Failure	ϕ	—	0.60 ²						
Concrete Breakout Strength in Shear										
	Outside Diameter of Anchor	d_o	in.	0.375	0.5	0.625	0.75	0.875	1	1.25
	Load-Bearing Length of Anchor in Shear	l_e	in.	h_{ef}						
	Strength Reduction Factor — Breakout Failure	ϕ	—	0.70 ³						
Concrete Pryout Strength in Shear										
	Coefficient for Pryout Strength	k_{cp}	—	1.0 for $h_{ef} < 2.50"$; 2.0 for $h_{ef} \geq 2.50"$						
	Strength Reduction Factor — Pryout Failure	ϕ	—	0.70 ⁴						

- The information presented in this table is to be used in conjunction with the design criteria of ACI 318-11.
- The value of ϕ applies when the load combinations of ACI 318 Section 9.2 are used. If the load combinations of ACI 318 Appendix C are used, refer to Section D.4.4 to determine the appropriate value of ϕ .
- The value of ϕ applies when both the load combinations of ACI 318 Section 9.2 are used and the requirements of Section D.4.3 (c) for Condition B are met. If the load combinations of ACI 318 Section 9.2 are used and the requirements of Section D.4.3 (c) for Condition A are met, refer to Section D.4.3 to determine the appropriate value of ϕ . If the load combinations of ACI 318 Appendix C are used, refer to Section D.4.4 to determine the appropriate value of ϕ .
- The value of ϕ applies when both the load combinations of ACI 318 Section 9.2 are used and the requirements of Section D.4.3 (c) for Condition B are met. If the load combinations of ACI 318 Appendix C are used, refer to Section D.4.4 to determine the appropriate value of ϕ .
- The values of V_{sa} are applicable for both cracked concrete and uncracked concrete. For anchors installed in regions assigned to Seismic Design Category C, D, E or F, V_{sa} must be multiplied by $\alpha_{V_{seis}}$.

* See page 12 for an explanation of the load table icons.

ET-HP® Design Information — Concrete

ET-HP® Tension Design Strengths for Threaded Rod Anchors in Normal-Weight Concrete ($f'_c = 2,500$ psi)



Rod Dia. (in.)	Nominal Embed. Depth (in.)	Minimum Dimensions for Uncracked (in.)		Minimum Dimensions for Cracked (in.)		Tension Design Strength Based on Concrete or Bond (lb.)							
						Edge Distances = c_{ac} on all sides				Edge Distances = $1\frac{1}{4}l$ on one side and c_{ac} on three sides			
						SDC A-B ⁶		SDC C-F ^{7,8}		SDC A-B ⁶		SDC C-F ^{7,8}	
						Uncracked	Cracked	Uncracked	Cracked	Uncracked	Cracked	Uncracked	Cracked
3/8	2 3/8	4 1/4	3 5/8	—	—	710	—	415	—	465	—	270	—
	3	4 7/8	4 1/2	4 7/8	2 1/4	895	365	525	215	440	305	255	180
	4 1/2	6 3/8	6 3/4	6 3/8	2 1/4	1,345	550	785	320	410	455	240	265
1/2	2 3/4	5 1/4	4 1/8	—	—	1,065	—	680	—	705	—	450	—
	4	6 1/2	6	6 1/2	3	1,550	810	985	515	635	565	405	360
	6	8 1/2	9	8 1/2	3	2,320	1,215	1,480	775	590	850	375	540
5/8	3 1/8	6 1/4	4 3/4	6 1/4	3 5/8	1,475	635	940	405	925	395	590	255
	5	8 1/8	7 1/2	8 1/8	3 5/8	2,360	1,015	1,505	645	865	635	550	405
	7 1/2	10 5/8	11 1/4	10 5/8	3 5/8	3,540	1,520	2,260	970	805	955	510	610
3/4	3 1/2	7 1/4	5 1/4	7 1/4	4 3/8	1,925	1,110	1,225	705	1,115	645	710	410
	6	9 3/4	9	9 3/4	4 3/8	3,300	1,900	2,105	1,215	1,110	1,100	710	700
	9	12 3/4	13 1/2	12 3/4	4 3/8	4,950	2,855	3,155	1,820	1,035	1,655	660	1,055
7/8	3 3/4	8 1/8	5 5/8	8 1/8	5	2,330	1,285	1,435	790	1,275	705	785	435
	7	11 3/8	10 1/2	11 3/8	5	4,355	2,400	2,675	1,475	1,380	1,315	850	805
	10 1/2	14 7/8	15 3/4	14 7/8	5 3/8	6,530	3,600	4,015	2,215	1,285	1,970	790	1,210
1	4	9	6	9	5 5/8	2,755	1,350	1,445	710	1,440	705	755	370
	8	13	12	13	5 5/8	5,505	2,695	2,890	1,415	1,665	1,410	875	740
	12	17	18	17	5 3/4	8,260	4,045	4,335	2,125	1,550	2,115	815	1,110
1 1/4	5	11 1/4	7 1/2	11 1/4	6 3/4	4,020	1,775	2,350	1,040	—	—	—	—
	10	16 1/4	15	16 1/4	6 3/4	8,040	3,550	4,705	2,075	—	—	—	—
	15	21 1/4	22 1/2	21 1/4	6 7/8	12,060	5,320	7,055	3,115	—	—	—	—

Adhesive Anchors

Threaded Rod Dia. (in.)	Tension Design Strength of Threaded Rod Steel (lb.)					
	ASTM F1554 GR 36	ASTM F1554 GR 55	ASTM F1554 GR 105	ASTM A193 B6	ASTM A193 B7	ASTM A193 B8/B8M
3/8	3,370	4,360	7,270	6,395	7,270	3,310
1/2	6,175	7,990	13,315	11,715	13,315	6,070
5/8	9,835	12,715	21,190	18,645	21,190	9,660
3/4	14,530	18,790	31,315	27,555	31,315	14,280
7/8	20,095	25,990	43,315	38,115	43,315	19,750
1	26,365	34,090	56,815	49,995	56,815	25,905
1 1/4	42,150	54,505	90,845	79,945	90,845	41,425

1. Tension design strength must be the lesser of the concrete, bond or threaded rod steel design strength.
2. Tension design strengths are based on the strength design provisions of ACI 318-11 Appendix D assuming dry concrete, periodic inspection, short-term temperature of 150°F and long-term temperature of 110°F.
3. Tabulated values are for a single anchor with no influence of another anchor.
4. Interpolation between embedment depths is not permitted.
5. Strength reduction factor, ϕ , is based on using a load combination from ACI 318-11 Section 9.2.
6. The tension design strength listed for SDC (Seismic Design Category) A-B may also be used in SDC C-F when the tension component of the strength-level seismic design load on the anchor does not exceed 20% of the total factored tension load on the anchor associated with the same load combination.
7. When designing anchorages in SDC C-F, the Designer shall consider the ductility requirements of ACI 318-11 Section D.3.3. Design strengths in **Bold** indicate that the anchor ductility requirements of D.3.3.4.3 (a)1 to 3 are satisfied when using ASTM F1554 Grade 36 threaded rod. Any other ductility requirements must be satisfied.
8. Tension design strengths in SDC C-F have been adjusted by 0.75 factor in accordance with ACI 318-11 Section D.3.3.4.4.

* See page 12 for an explanation of the load table icons.

ET-HP® Design Information — Concrete

ET-HP® Allowable Tension Loads for Threaded Rod Anchors in Normal-Weight Concrete (f'c = 2,500 psi) — Static Load

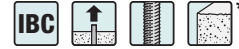

Adhesive Anchors

Rod Dia. (in.)	Nominal Embed. Depth (in.)	Minimum Dimensions for Uncracked (in.)		Minimum Dimensions for Cracked (in.)		Allowable Tension Load Based on Concrete or Bond (lb.)			
		ha	cac	ha	cac	Edge Distances = cac on all sides		Edge Distances = 1¼" on one side and cac on three sides	
						Uncracked	Cracked	Uncracked	Cracked
¾	2¾	4¼	3¾	—	—	505	—	330	—
	3	4⅞	4½	4⅞	2¼	640	260	315	220
	4½	6¾	6¾	6¾	2¼	960	395	295	325
½	2¾	5¼	4⅞	—	—	760	—	505	—
	4	6½	6	6½	3	1,105	580	455	405
	6	8½	9	8½	3	1,655	870	420	605
⅝	3⅞	6¼	4¾	6¼	3¾	1,055	455	660	280
	5	8⅞	7½	8⅞	3¾	1,685	725	620	455
	7½	10⅞	11¼	10⅞	3¾	2,530	1,085	575	680
¾	3½	7¼	5¼	7¼	4¾	1,375	795	795	460
	6	9¾	9	9¾	4¾	2,355	1,355	795	785
	9	12¾	13½	12¾	4¾	3,535	2,040	740	1,180
⅞	3¾	8⅞	5⅞	8⅞	5	1,665	920	910	505
	7	11⅞	10½	11⅞	5	3,110	1,715	985	940
	10½	14⅞	15¾	14⅞	5¾	4,665	2,570	920	1,405
1	4	9	6	9	5⅞	1,970	965	1,030	505
	8	13	12	13	5⅞	3,930	1,925	1,190	1,005
	12	17	18	17	5¾	5,900	2,890	1,105	1,510
1¼	5	11¼	7½	11¼	6¾	2,870	1,270	—	—
	10	16¼	15	16¼	6¾	5,745	2,535	—	—
	15	21¼	22½	21¼	6⅞	8,615	3,800	—	—

Threaded Rod Dia. (in.)	Allowable Tension Load of Threaded Rod Steel (lb.)					
	ASTM F1554 GR 36	ASTM F1554 GR 55	ASTM F1554 GR 105	ASTM A193 B6	ASTM A193 B7	ASTM A193 B8/B8M
¾	2,405	3,115	5,195	4,570	5,195	2,365
½	4,410	5,705	9,510	8,370	9,510	4,335
⅝	7,025	9,080	15,135	13,320	15,135	6,900
¾	10,380	13,420	22,370	19,680	22,370	10,200
⅞	14,355	18,565	30,940	27,225	30,940	14,105
1	18,830	24,350	40,580	35,710	40,580	18,505
1¼	30,105	38,930	64,890	57,105	64,890	29,590

1. Allowable tension load must be the lesser of the concrete, bond or threaded rod steel load.
2. Allowable tension loads are calculated based on the strength design provisions of ACI 318-11 Appendix D assuming dry concrete, periodic inspection, short-term temperature of 150°F and long-term temperature of 110°F. Tension design strengths are converted to allowable tension loads using a conversion factor of $\alpha = 1.4$. The conversion factor α is based on the load combination 1.2D + 1.6L assuming 50% dead load and 50% live load: $1.2(0.5) + 1.6(0.5) = 1.4$.
3. Tabulated values are for a single anchor with no influence of another anchor.
4. Interpolation between embedment depths is not permitted.

* See page 12 for an explanation of the load table icons.

ET-HP® Design Information — Concrete

ET-HP® Allowable Tension Loads for Threaded Rod Anchors in Normal-Weight Concrete ($f'_c = 2,500$ psi) — Wind Load

*

Rod Dia. (in.)	Nominal Embed. Depth (in.)	Minimum Dimensions for Uncracked (in.)		Minimum Dimensions for Cracked (in.)		Allowable Tension Load Based on Concrete or Bond (lb.)			
		h_a	c_{ac}	h_a	c_{ac}	Edge Distances = c_{ac} on all sides		Edge Distances = 1¼" on one side and c_{ac} on three sides	
						Uncracked	Cracked	Uncracked	Cracked
¾	2¾	4¼	3⅝	—	—	425	—	280	—
	3	4⅞	4½	4⅞	2¼	535	220	265	185
	4½	6⅞	6¾	6⅞	2¼	805	330	245	275
½	2¾	5¼	4⅞	—	—	640	—	425	—
	4	6½	6	6½	3	930	485	380	340
	6	8½	9	8½	3	1,390	730	355	510
⅝	3⅞	6¼	4¾	6¼	3⅝	885	380	555	235
	5	8⅞	7½	8⅞	3⅝	1,415	610	520	380
	7½	10⅞	11¼	10⅞	3⅝	2,125	910	485	575
¾	3½	7¼	5¼	7¼	4⅞	1,155	665	670	385
	6	9¾	9	9¾	4⅞	1,980	1,140	665	660
	9	12¾	13½	12¾	4⅞	2,970	1,715	620	995
7/8	3¾	8⅞	5⅝	8⅞	5	1,400	770	765	425
	7	11⅞	10½	11⅞	5	2,615	1,440	830	790
	10½	14⅞	15¾	14⅞	5⅝	3,920	2,160	770	1,180
1	4	9	6	9	5⅝	1,655	810	865	425
	8	13	12	13	5⅝	3,305	1,615	1,000	845
	12	17	18	17	5¾	4,955	2,425	930	1,270
1¼	5	11¼	7½	11¼	6¾	2,410	1,065	—	—
	10	16¼	15	16¼	6¾	4,825	2,130	—	—
	15	21¼	22½	21¼	6⅞	7,235	3,190	—	—

Threaded Rod Dia. (in.)	Allowable Tension Load of Threaded Rod Steel (lb.)					
	ASTM F1554 GR 36	ASTM F1554 GR 55	ASTM F1554 GR 105	ASTM A193 B6	ASTM A193 B7	ASTM A193 B8/B8M
¾	2,020	2,615	4,360	3,835	4,360	1,985
½	3,705	4,795	7,990	7,030	7,990	3,640
⅝	5,900	7,630	12,715	11,185	12,715	5,795
¾	8,720	11,275	18,790	16,535	18,790	8,570
7/8	12,055	15,595	25,990	22,870	25,990	11,850
1	15,820	20,455	34,090	29,995	34,090	15,545
1¼	25,290	32,705	54,505	47,965	54,505	24,855

1. Allowable tension load must be the lesser of the concrete, bond or threaded rod steel load.
2. Allowable tension loads are calculated based on the strength design provisions of ACI 318-11 Appendix D assuming dry concrete, periodic inspection, short-term temperature of 150°F and long-term temperature of 110°F. Tension design strengths are converted to allowable tension loads using a conversion factor of $\alpha = \frac{1}{1.67} = 1.67$. The conversion factor α is based on the load combination assuming 100% wind load.
3. Tabulated values are for a single anchor with no influence of another anchor.
4. Interpolation between embedment depths is not permitted.

* See page 12 for an explanation of the load table icons.

ET-HP® Design Information — Concrete

ET-HP® Allowable Tension Loads for Threaded Rod Anchors in Normal-Weight Concrete
($f'_c = 2,500$ psi) — Seismic Load

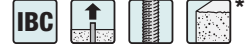

Adhesive Anchors

Rod Dia. (in.)	Nominal Embed. Depth (in.)	Minimum Dimensions for Uncracked (in.)		Minimum Dimensions for Cracked (in.)		Allowable Tension Load Based on Concrete or Bond (lb.)							
		h_a	c_{ac}	h_a	c_{ac}	Edge Distances = c_{ac} on all sides				Edge Distances = $1\frac{3}{4}$ " on one side and c_{ac} on three sides			
						SDC A-B ⁵		SDC C-F ^{6,7}		SDC A-B ⁵		SDC C-F ^{6,7}	
		Uncracked	Cracked	Uncracked	Cracked	Uncracked	Cracked	Uncracked	Cracked	Uncracked	Cracked		
3/8	2 3/8	4 1/4	3 5/8	—	—	495	—	290	—	325	—	190	—
	3	4 7/8	4 1/2	4 7/8	2 1/4	625	255	370	150	310	215	180	125
	4 1/2	6 3/8	6 3/4	6 3/8	2 1/4	940	385	550	225	285	320	170	185
1/2	2 3/4	5 1/4	4 1/8	—	—	745	—	475	—	495	—	315	—
	4	6 1/2	6	6 1/2	3	1,085	565	690	360	445	395	285	250
	6	8 1/2	9	8 1/2	3	1,625	850	1,035	545	415	595	265	380
5/8	3 1/8	6 1/4	4 3/4	6 1/4	3 3/8	1,035	445	660	285	650	275	415	180
	5	8 1/8	7 1/2	8 1/8	3 3/8	1,650	710	1,055	450	605	445	385	285
	7 1/2	10 5/8	11 1/4	10 5/8	3 3/8	2,480	1,065	1,580	680	565	670	355	425
3/4	3 1/2	7 1/4	5 1/4	7 1/4	4 3/8	1,350	775	860	495	780	450	495	285
	6	9 3/4	9	9 3/4	4 3/8	2,310	1,330	1,475	850	775	770	495	490
	9	12 3/4	13 1/2	12 3/4	4 5/8	3,465	2,000	2,210	1,275	725	1,160	460	740
7/8	3 3/4	8 1/8	5 5/8	8 1/8	5	1,630	900	1,005	555	895	495	550	305
	7	11 3/8	10 1/2	11 3/8	5	3,050	1,680	1,875	1,035	965	920	595	565
	10 1/2	14 7/8	15 3/4	14 7/8	5 5/8	4,570	2,520	2,810	1,550	900	1,380	555	845
1	4	9	6	9	5 5/8	1,930	945	1,010	495	1,010	495	530	260
	8	13	12	13	5 5/8	3,855	1,885	2,025	990	1,165	985	615	520
	12	17	18	17	5 3/4	5,780	2,830	3,035	1,490	1,085	1,480	570	775
1 1/4	5	11 1/4	7 1/2	11 1/4	6 3/4	2,815	1,245	1,645	730	—	—	—	—
	10	16 1/4	15	16 1/4	6 3/4	5,630	2,485	3,295	1,455	—	—	—	—
	15	21 1/4	22 1/2	21 1/4	6 7/8	8,440	3,725	4,940	2,180	—	—	—	—

Threaded Rod Dia. (in.)	Allowable Tension Load of Threaded Rod Steel (lb.)					
	ASTM F1554 GR 36	ASTM F1554 GR 55	ASTM F1554 GR 105	ASTM A193 B6	ASTM A193 B7	ASTM A193 B8/B8M
3/8	2,360	3,050	5,090	4,475	5,090	2,315
1/2	4,325	5,595	9,320	8,200	9,320	4,250
5/8	6,885	8,900	14,835	13,050	14,835	6,760
3/4	10,170	13,155	21,920	19,290	21,920	9,995
7/8	14,065	18,195	30,320	26,680	30,320	13,825
1	18,455	23,865	39,770	34,995	39,770	18,135
1 1/4	29,505	38,155	63,590	55,960	63,590	29,000

1. Allowable tension load must be the lesser of the concrete, bond or threaded rod steel load.
2. Allowable tension loads are calculated based on the strength design provisions of ACI 318-11 Appendix D assuming dry concrete, periodic inspection, short-term temperature of 150°F and long-term temperature of 110°F. Tension design strengths are converted to allowable tension loads using a conversion factor of $\alpha = \frac{1}{1.43} = 0.7$. The conversion factor α is based on the load combination assuming 100% seismic load.
3. Tabulated values are for a single anchor with no influence of another anchor.
4. Interpolation between embedment depths is not permitted.
5. The allowable tension load listed for SDC (Seismic Design Category) A-B may also be used in SDC C-F when the tension component of the strength-level seismic design load on the anchor does not exceed 20% of the total factored tension load on the anchor associated with the same load combination.
6. When designing anchorages in SDC C-F, the Designer shall consider the ductility requirements of ACI 318-11 Section D.3.3.
7. Design strengths in **Bold** indicate that the anchor ductility requirements of D.3.3.4.3 (a)1 to 3 are satisfied when using ASTM F1554 Grade 36 threaded rod. Any other ductility requirements must be satisfied.
8. Allowable tension loads in SDC C-F have been adjusted by 0.75 factor in accordance with ACI 318-11 Section D.3.3.4.4.

* See page 12 for an explanation of the load table icons.

ET-HP® Design Information — Concrete



ET-HP® Tension Design Strengths for Rebar in Normal-Weight Concrete ($f'_c = 2,500$ psi)

Rebar Size	Nominal Embed. Depth (in.)	Minimum Dimensions for Uncracked (in.)		Minimum Dimensions for Cracked (in.)		Tension Design Strength Based on Concrete or Bond (lb.)							
		h_a	c_{ac}	h_a	c_{ac}	Edge Distances = c_{ac} on all sides				Edge Distances = $1\frac{3}{4}$ " on one side and c_{ac} on three sides			
						SDC A-B ⁶		SDC C-F ^{7,8}		SDC A-B ⁶		SDC C-F ^{7,8}	
		Uncracked	Cracked	Uncracked	Cracked	Uncracked	Cracked	Uncracked	Cracked	Uncracked	Cracked		
#3	2 $\frac{3}{8}$	4 $\frac{1}{4}$	3 $\frac{5}{8}$	—	—	670	—	500	—	445	—	335	—
	3	4 $\frac{7}{8}$	4 $\frac{1}{2}$	4 $\frac{7}{8}$	2 $\frac{1}{4}$	845	295	635	220	420	250	315	190
	4 $\frac{1}{2}$	6 $\frac{3}{8}$	6 $\frac{3}{4}$	6 $\frac{3}{8}$	2 $\frac{1}{4}$	1,270	440	950	330	390	375	295	280
#4	2 $\frac{3}{4}$	5 $\frac{1}{4}$	4 $\frac{1}{8}$	—	—	1,010	—	755	—	675	—	505	—
	4	6 $\frac{1}{2}$	6	6 $\frac{1}{2}$	3	1,465	575	1,100	430	610	410	455	310
	6	8 $\frac{1}{2}$	9	8 $\frac{1}{2}$	3	2,200	865	1,650	650	565	615	425	460
#5	3 $\frac{1}{8}$	6 $\frac{1}{4}$	4 $\frac{3}{4}$	6 $\frac{1}{4}$	3 $\frac{5}{8}$	1,390	615	1,040	460	885	390	660	295
	5	8 $\frac{1}{8}$	7 $\frac{1}{2}$	8 $\frac{1}{8}$	3 $\frac{5}{8}$	2,220	985	1,665	735	820	625	615	470
	7 $\frac{1}{2}$	10 $\frac{5}{8}$	11 $\frac{1}{4}$	10 $\frac{5}{8}$	3 $\frac{5}{8}$	3,330	1,475	2,500	1,105	760	940	570	705
#6	3 $\frac{1}{2}$	7 $\frac{1}{4}$	5 $\frac{1}{4}$	7 $\frac{1}{4}$	4 $\frac{1}{4}$	1,805	895	1,355	670	1,060	525	795	395
	6	9 $\frac{3}{4}$	9	9 $\frac{3}{4}$	4 $\frac{1}{4}$	3,095	1,535	2,325	1,150	1,050	900	790	675
	9	12 $\frac{3}{4}$	13 $\frac{1}{2}$	12 $\frac{3}{4}$	4 $\frac{1}{4}$	4,645	2,300	3,485	1,725	980	1,350	735	1,015
#7	3 $\frac{3}{4}$	8 $\frac{1}{8}$	5 $\frac{5}{8}$	8 $\frac{1}{8}$	4 $\frac{7}{8}$	2,190	1,195	1,645	895	1,215	660	910	495
	7	11 $\frac{3}{8}$	10 $\frac{1}{2}$	11 $\frac{3}{8}$	4 $\frac{7}{8}$	4,090	2,225	3,065	1,670	1,305	1,230	980	925
	10 $\frac{1}{2}$	14 $\frac{7}{8}$	15 $\frac{3}{4}$	14 $\frac{7}{8}$	5 $\frac{1}{8}$	6,135	3,340	4,600	2,505	1,215	1,850	910	1,385
#8	4	9	6	9	5 $\frac{3}{8}$	2,580	1,560	1,935	1,170	1,365	825	1,025	620
	8	13	12	13	5 $\frac{3}{8}$	5,160	3,120	3,870	2,340	1,570	1,650	1,175	1,240
	12	17	18	17	6 $\frac{5}{8}$	7,745	4,680	5,810	3,510	1,460	2,475	1,095	1,860
#10	5	11 $\frac{1}{4}$	7 $\frac{1}{2}$	11 $\frac{1}{4}$	6 $\frac{1}{2}$	3,780	2,745	2,835	2,060	—	—	—	—
	10	16 $\frac{1}{4}$	15	16 $\frac{1}{4}$	7	7,555	5,490	5,665	4,115	—	—	—	—
	15	21 $\frac{1}{4}$	22 $\frac{1}{2}$	21 $\frac{1}{4}$	9 $\frac{1}{8}$	11,335	8,230	8,500	6,175	—	—	—	—

Rebar Size	Tension Design Strength of Rebar Steel (lb.)	
	ASTM A615 GR 60	ASTM A706 GR 60
#3	6,435	5,720
#4	11,700	10,400
#5	18,135	16,120
#6	25,740	22,880
#7	35,100	31,200
#8	46,215	41,080
#10	74,100	66,040

1. Tension design strength must be the lesser of the concrete, bond or rebar steel design strength.
2. Tension design strengths are based on the strength design provisions of ACI 318-11 Appendix D assuming dry concrete, periodic inspection, short-term temperature of 150°F and long-term temperature of 110°F.
3. Tabulated values are for a single anchor with no influence of another anchor.
4. Interpolation between embedment depths is not permitted.
5. Strength reduction factor, ϕ , is based on using a load combination from ACI 318-11 Section 9.2.
6. The tension design strength listed for SDC (Seismic Design Category) A-B may also be used in SDC C-F when the tension component of the strength-level seismic design load on the anchor does not exceed 20% of the total factored tension load on the anchor associated with the same load combination.
7. When designing anchorages in SDC C-F, the Designer shall consider the ductility requirements of ACI 318-11 Section D.3.3.
8. Tension design strengths in SDC C-F have been adjusted by 0.75 factor in accordance with ACI 318-11 Section D.3.3.4.4.

* See page 12 for an explanation of the load table icons.

ET-HP® Design Information — Concrete

ET-HP® Allowable Tension Loads for Rebar in Normal-Weight Concrete
($f'_c = 2,500$ psi) — Static Load

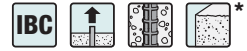

Adhesive Anchors

Rebar Size	Nominal Embed. Depth (in.)	Minimum Dimensions for Uncracked (in.)		Minimum Dimensions for Cracked (in.)		Allowable Tension Load Based on Concrete or Bond (lb.)			
		h_a	c_{ac}	h_a	c_{ac}	Edge Distances = c_{ac} on all sides		Edge Distances = $1\frac{1}{4}''$ on one side and c_{ac} on three sides	
						Uncracked	Cracked	Uncracked	Cracked
#3	2¾	4¼	3½	—	—	480	—	320	—
	3	4⅞	4½	4⅞	2¼	605	210	300	180
	4½	6¾	6¾	6¾	2¼	905	315	280	270
#4	2¾	5¼	4½	—	—	720	—	480	—
	4	6½	6	6½	3	1,045	410	435	295
	6	8½	9	8½	3	1,570	620	405	440
#5	3½	6¼	4¾	6¼	3½	995	440	630	280
	5	8½	7½	8½	3½	1,585	705	585	445
	7½	10¾	11¼	10¾	3½	2,380	1,055	545	670
#6	3½	7¼	5¼	7¼	4¼	1,290	640	755	375
	6	9¾	9	9¾	4¼	2,210	1,095	750	645
	9	12¾	13½	12¾	4¼	3,320	1,645	700	965
#7	3¾	8½	5½	8½	4⅞	1,565	855	870	470
	7	11¾	10½	11¾	4⅞	2,920	1,590	930	880
	10½	14⅞	15¾	14⅞	5½	4,380	2,385	870	1,320
#8	4	9	6	9	5¾	1,845	1,115	975	590
	8	13	12	13	5¾	3,685	2,230	1,120	1,180
	12	17	18	17	6¾	5,530	3,345	1,045	1,770
#10	5	11¼	7½	11¼	6½	2,700	1,960	—	—
	10	16¼	15	16¼	7	5,395	3,920	—	—
	15	21¼	22½	21¼	9½	8,095	5,880	—	—

Rebar Size	Allowable Tension Load of Rebar Steel (lb.)	
	ASTM A615 GR 60	ASTM A706 GR 60
#3	4,595	4,085
#4	8,355	7,430
#5	12,955	11,515
#6	18,385	16,345
#7	25,070	22,285
#8	33,010	29,345
#10	52,930	47,170

1. Allowable tension load must be the lesser of the concrete, bond or rebar steel load.
2. Allowable tension loads are calculated based on the strength design provisions of ACI 318-11 Appendix D assuming dry concrete, periodic inspection, short-term temperature of 150°F and long-term temperature of 110°F. Tension design strengths are converted to allowable tension loads using a conversion factor of $\alpha = 1.4$. The conversion factor α is based on the load combination $1.2D + 1.6L$ assuming 50% dead load and 50% live load: $1.2(0.5) + 1.6(0.5) = 1.4$.
3. Tabulated values are for a single anchor with no influence of another anchor.
4. Interpolation between embedment depths is not permitted.

* See page 12 for an explanation of the load table icons.

ET-HP® Design Information — Concrete

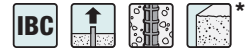
ET-HP® Allowable Tension Loads for Rebar in Normal-Weight Concrete
($f'_c = 2,500$ psi) — Wind Load

Rebar Size	Nominal Embed. Depth (in.)	Minimum Dimensions for Uncracked (in.)		Minimum Dimensions for Cracked (in.)		Allowable Tension Load Based on Concrete or Bond (lb.)			
		h_a	c_{ac}	h_a	c_{ac}	Edge Distances = c_{ac} on all sides		Edge Distances = $1\frac{1}{4}''$ on one side and c_{ac} on three sides	
						Uncracked	Cracked	Uncracked	Cracked
#3	2 $\frac{3}{8}$	4 $\frac{1}{4}$	3 $\frac{5}{8}$	—	—	400	—	265	—
	3	4 $\frac{7}{8}$	4 $\frac{1}{2}$	4 $\frac{7}{8}$	2 $\frac{1}{4}$	505	175	250	150
	4 $\frac{1}{2}$	6 $\frac{3}{8}$	6 $\frac{3}{4}$	6 $\frac{3}{8}$	2 $\frac{1}{4}$	760	265	235	225
#4	2 $\frac{3}{4}$	5 $\frac{1}{4}$	4 $\frac{1}{8}$	—	—	605	—	405	—
	4	6 $\frac{1}{2}$	6	6 $\frac{1}{2}$	3	880	345	365	245
	6	8 $\frac{1}{2}$	9	8 $\frac{1}{2}$	3	1,320	520	340	370
#5	3 $\frac{1}{8}$	6 $\frac{1}{4}$	4 $\frac{3}{4}$	6 $\frac{1}{4}$	3 $\frac{5}{8}$	835	370	530	235
	5	8 $\frac{1}{8}$	7 $\frac{1}{2}$	8 $\frac{1}{8}$	3 $\frac{5}{8}$	1,330	590	490	375
	7 $\frac{1}{2}$	10 $\frac{5}{8}$	11 $\frac{1}{4}$	10 $\frac{5}{8}$	3 $\frac{5}{8}$	2,000	885	455	565
#6	3 $\frac{1}{2}$	7 $\frac{1}{4}$	5 $\frac{1}{4}$	7 $\frac{1}{4}$	4 $\frac{1}{4}$	1,085	535	635	315
	6	9 $\frac{3}{4}$	9	9 $\frac{3}{4}$	4 $\frac{1}{4}$	1,855	920	630	540
	9	12 $\frac{3}{4}$	13 $\frac{1}{2}$	12 $\frac{3}{4}$	4 $\frac{1}{4}$	2,785	1,380	590	810
#7	3 $\frac{3}{4}$	8 $\frac{1}{8}$	5 $\frac{5}{8}$	8 $\frac{1}{8}$	4 $\frac{7}{8}$	1,315	715	730	395
	7	11 $\frac{3}{8}$	10 $\frac{1}{2}$	11 $\frac{3}{8}$	4 $\frac{7}{8}$	2,455	1,335	785	740
	10 $\frac{1}{2}$	14 $\frac{7}{8}$	15 $\frac{3}{4}$	14 $\frac{7}{8}$	5 $\frac{1}{8}$	3,680	2,005	730	1,110
#8	4	9	6	9	5 $\frac{3}{8}$	1,550	935	820	495
	8	13	12	13	5 $\frac{3}{8}$	3,095	1,870	940	990
	12	17	18	17	6 $\frac{5}{8}$	4,645	2,810	875	1,485
#10	5	11 $\frac{1}{4}$	7 $\frac{1}{2}$	11 $\frac{1}{4}$	6 $\frac{1}{2}$	2,270	1,645	—	—
	10	16 $\frac{1}{4}$	15	16 $\frac{1}{4}$	7	4,535	3,295	—	—
	15	21 $\frac{1}{4}$	22 $\frac{1}{2}$	21 $\frac{1}{4}$	9 $\frac{1}{8}$	6,800	4,940	—	—

Rebar Size	Allowable Tension Load of Rebar Steel (lb.)	
	ASTM A615 GR 60	ASTM A706 GR 60
#3	3,860	3,430
#4	7,020	6,240
#5	10,880	9,670
#6	15,445	13,730
#7	21,060	18,720
#8	27,730	24,650
#10	44,460	39,625

1. Allowable tension load must be the lesser of the concrete, bond or rebar steel load.
2. Allowable tension loads are calculated based on the strength design provisions of ACI 318-11 Appendix D assuming dry concrete, periodic inspection, short-term temperature of 150°F and long-term temperature of 110°F. Tension design strengths are converted to allowable tension loads using a conversion factor of $\alpha = \frac{1}{1.67} = 1.67$. The conversion factor α is based on the load combination assuming 100% wind load.
3. Tabulated values are for a single anchor with no influence of another anchor.
4. Interpolation between embedment depths is not permitted.

* See page 12 for an explanation of the load table icons.

ET-HP® Design Information — Concrete

ET-HP® Allowable Tension Loads for Rebar in Normal-Weight Concrete
(f'c = 2,500 psi) — Seismic Load

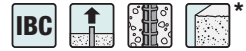

Adhesive Anchors

Rebar Size	Nominal Embed. Depth (in.)	Minimum Dimensions for Uncracked (in.)		Minimum Dimensions for Cracked (in.)		Allowable Tension Load Based on Concrete or Bond (lb.)							
						Edge Distances = c _{ac} on all sides				Edge Distances = 1¼" on one side and c _{ac} on three sides			
						SDC A-B ⁵		SDC C-F ^{6,7}		SDC A-B ⁵		SDC C-F ^{6,7}	
						Uncracked	Cracked	Uncracked	Cracked	Uncracked	Cracked	Uncracked	Cracked
#3	2¾	4¼	3⅝	—	—	470	—	350	—	310	—	235	—
	3	4⅞	4½	4⅞	2¼	590	205	445	155	295	175	220	135
	4½	6⅜	6¾	6⅜	2¼	890	310	665	230	275	265	205	195
#4	2¾	5¼	4⅞	—	—	705	—	530	—	475	—	355	—
	4	6½	6	6½	3	1,025	405	770	300	425	285	320	215
	6	8½	9	8½	3	1,540	605	1,155	455	395	430	300	320
#5	3⅞	6¼	4¾	6¼	3⅝	975	430	730	320	620	275	460	205
	5	8⅞	7½	8⅞	3⅝	1,555	690	1,165	515	575	440	430	330
	7½	10⅝	11¼	10⅝	3⅝	2,330	1,035	1,750	775	530	660	400	495
#6	3½	7¼	5¼	7¼	4¼	1,265	625	950	470	740	370	555	275
	6	9¾	9	9¾	4¼	2,165	1,075	1,630	805	735	630	555	475
	9	12¾	13½	12¾	4¼	3,250	1,610	2,440	1,210	685	945	515	710
#7	3¾	8⅞	5⅝	8⅞	4⅞	1,535	835	1,150	625	850	460	635	345
	7	11⅝	10½	11⅝	4⅞	2,865	1,560	2,145	1,170	915	860	685	650
	10½	14⅞	15¾	14⅞	5⅞	4,295	2,340	3,220	1,755	850	1,295	635	970
#8	4	9	6	9	5⅝	1,805	1,090	1,355	820	955	580	720	435
	8	13	12	13	5⅝	3,610	2,185	2,710	1,640	1,100	1,155	825	870
	12	17	18	17	6⅝	5,420	3,275	4,065	2,455	1,020	1,735	765	1,300
#10	5	11¼	7½	11¼	6½	2,645	1,920	1,985	1,440	—	—	—	—
	10	16¼	15	16¼	7	5,290	3,845	3,965	2,880	—	—	—	—
	15	21¼	22½	21¼	9⅞	7,935	5,760	5,950	4,325	—	—	—	—

Rebar Size	Allowable Tension Load of Rebar Steel (lb.)	
	ASTM A615 GR 60	ASTM A706 GR 60
#3	4,505	4,005
#4	8,190	7,280
#5	12,695	11,285
#6	18,020	16,015
#7	24,570	21,840
#8	32,350	28,755
#10	51,870	46,230

1. Allowable tension load must be the lesser of the concrete, bond or rebar steel load.
2. Allowable tension loads are calculated based on the strength design provisions of ACI 318-11 Appendix D assuming dry concrete, periodic inspection, short-term temperature of 150°F and long-term temperature of 110°F. Tension design strengths are converted to allowable tension loads using a conversion factor of $\alpha = 1/1.43 = 0.7$. The conversion factor α is based on the load combination assuming 100% seismic load.
3. Tabulated values are for a single anchor with no influence of another anchor.
4. Interpolation between embedment depths is not permitted.
5. The allowable tension load listed for SDC (Seismic Design Category) A-B may also be used in SDC C-F when the tension component of the strength-level seismic design load on the anchor does not exceed 20% of the total factored tension load on the anchor associated with the same load combination.
6. When designing anchorages in SDC C-F, the Designer shall consider the ductility requirements of ACI 318-11 Section D.3.3.
7. Allowable tension loads in SDC C-F have been adjusted by 0.75 factor in accordance with ACI 318-11 Section D.3.3.4.4.

* See page 12 for an explanation of the load table icons.

ET-HP® Design Information — Concrete

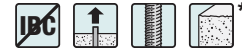
ET-HP® Allowable Tension Loads for
Threaded Rod Anchors in Normal-Weight Concrete

Rod Dia. in. (mm)	Drill Bit Dia. in.	Embed. Depth in. (mm)	Critical Edge Dist. in. (mm)	Critical Spacing Dist. in. (mm)	Tension Load Based on Bond Strength			Tension Load Based on Steel Strength		
					$f'_c \geq 2,000$ psi (13.8 MPa) Concrete			F1554 Grade 36	A193 GR B7	F593 304SS
					Ultimate lb. (kN)	Std. Dev. lb. (kN)	Allowable lb. (kN)	Allowable lb. (kN)	Allowable lb. (kN)	Allowable lb. (kN)
3/8 (9.5)	1/2	3 1/2 (89)	5 1/4 (133)	14 (356)	8,777 (39.0)	324 (1.4)	2,195 (9.8)	2,105 (9.4)	4,535 (20.2)	3,630 (16.1)
1/2 (12.7)	5/8	4 1/4 (108)	6 3/8 (162)	17 (432)	15,368 (68.4)	605 (2.7)	3,840 (17.1)	3,750 (16.7)	8,080 (35.9)	6,470 (28.8)
5/8 (15.9)	3/4	5 (127)	7 1/2 (191)	20 (508)	22,877 (101.8)	718 (3.2)	5,720 (25.4)	5,875 (26.1)	12,660 (56.3)	10,120 (45.0)
3/4 (19.1)	7/8	6 3/4 (171)	10 1/8 (257)	27 (686)	35,459 (157.7)	4,940 (22.0)	8,865 (39.4)	8,460 (37.6)	18,230 (81.1)	12,400 (55.2)
7/8 (22.2)	1	7 3/4 (197)	11 5/8 (295)	31 (787)	43,596 (193.9)	1,130 (5.0)	10,900 (48.5)	11,500 (51.2)	24,785 (110.2)	16,860 (75.0)
1 (25.4)	1 1/8	9 (229)	13 1/2 (343)	36 (914)	47,333 (210.5)	1,243 (5.5)	11,835 (52.6)	15,025 (66.8)	32,380 (144.0)	22,020 (97.9)
1 1/8 (28.6)	1 1/4	10 1/8 (257)	15 1/4 (387)	40 1/2 (1029)	61,840 (275.1)	—	15,460 (68.8)	19,025 (84.6)	41,000 (182.4)	27,880 (124.0)
1 1/4 (31.8)	1 3/8	11 1/4 (286)	16 7/8 (429)	45 (1143)	78,748 (350.3)	4,738 (21.1)	19,685 (87.6)	23,490 (104.5)	50,620 (225.2)	34,420 (153.1)

1. Allowable load must be the lesser of the bond or steel strength.
2. The allowable loads listed under allowable bond are based on a safety factor of 4.0.
3. Refer to allowable load-adjustment factors for spacing and edge distance on pages 84 and 85.
4. Refer to in-service temperature sensitivity chart below for allowable load adjustment for temperature.

5. Anchors are permitted to be used within fire-resistive construction, provided the anchors resist wind or seismic loads only. For use in fire-resistive construction, the anchors can also be permitted to be used to resist gravity loads, provided special consideration has been given to fire-exposure conditions.
6. Anchors are not permitted to resist tension forces in overhead or wall installations unless proper consideration is given to fire-exposure and elevated-temperature conditions.

In-Service Temperature Sensitivity

Base Material Temperature		Percent Allowable Load
°F	°C	
40	4	100%
70	21	100%
110	43	100%
135	57	85%
150	66	69%

1. Refer to temperature-sensitivity chart for allowable bond strength reduction for temperature. See page 319 for more information.
2. Percent allowable load may be linearly interpolated for intermediate base material temperatures.
3. °C = (°F-32) / 1.8

ET-HP® Design Information — Concrete

ET-HP® Allowable Shear Loads for Threaded Rod Anchors in Normal-Weight Concrete

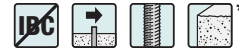

Adhesive Anchors

Rod Dia. in. (mm)	Drill Bit Dia. in.	Embed. Depth in. (mm)	Critical Edge Dist. in. (mm)	Critical Spacing Dist. in. (mm)	Shear Load Based on Concrete Edge Distance			Shear Load Based on Steel Strength		
					$f'_c \geq 2,000$ psi (13.8 MPa) Concrete			F1554 Grade 36	A193 GR B7	F593 304SS
					Ultimate lb. (kN)	Std. Dev. lb. (kN)	Allowable lb. (kN)	Allowable lb. (kN)	Allowable lb. (kN)	Allowable lb. (kN)
3/8 (9.5)	1/2	3 1/2 (89)	5 1/4 (133)	5 1/4 (133)	7,615 (33.9)	591 (2.6)	1,905 (8.5)	1,085 (4.8)	2,340 (10.4)	1,870 (8.3)
1/2 (12.7)	5/8	4 1/4 (108)	6 3/8 (162)	6 3/8 (162)	11,273 (50.1)	1,502 (6.7)	2,820 (12.5)	1,930 (8.6)	4,160 (18.5)	3,330 (14.8)
5/8 (15.9)	3/4	5 (127)	7 1/2 (191)	7 1/2 (191)	19,559 (87.0)	1,289 (5.7)	4,890 (21.8)	3,025 (13.5)	6,520 (29.0)	5,220 (23.2)
3/4 (19.1)	7/8	6 3/4 (171)	10 1/8 (257)	10 1/8 (257)	27,696 (123.2)	2,263 (10.1)	6,925 (30.8)	4,360 (19.4)	9,390 (41.8)	6,385 (28.4)
7/8 (22.2)	1	7 3/4 (197)	11 5/8 (295)	11 5/8 (295)	—	—	6,925 (30.8)	5,925 (26.4)	12,770 (56.8)	8,685 (38.6)
1 (25.4)	1 1/8	9 (229)	13 1/2 (343)	13 1/2 (343)	53,960 (240.0)	3,821 (17.0)	13,490 (60.0)	7,740 (34.4)	16,680 (74.2)	11,345 (50.5)
1 1/8 (28.6)	1 1/4	10 1/8 (257)	15 1/4 (387)	15 1/4 (387)	59,280 (263.7)	—	14,820 (65.9)	9,800 (43.6)	21,125 (94.0)	14,365 (63.9)
1 1/4 (31.8)	1 3/8	11 1/4 (286)	16 7/8 (429)	16 7/8 (429)	64,572 (287.2)	3,503 (15.6)	16,145 (71.8)	12,100 (53.8)	26,075 (116.0)	17,730 (78.9)

1. Allowable load must be the lesser of the load based on concrete edge distance or steel strength.
2. The allowable loads based on concrete edge distance are based on a safety factor of 4.0.
3. Refer to allowable load-adjustment factors for spacing and edge distance on pages 84 and 85.
4. Refer to in-service temperature sensitivity chart on page 77 for allowable load adjustment for temperature.
5. Anchors are permitted to be used within fire-resistive construction, provided the anchors resist wind or seismic loads only. For use in fire-resistive construction, the anchors can also be permitted to be used to resist gravity loads, provided special consideration has been given to fire-exposure conditions.

ET-HP® Allowable Tension Loads for Threaded Rod Anchors in Normal-Weight Concrete Stemwall



Rod Dia. in. (mm)	Drill Bit Dia. in.	Embed. Depth in. (mm)	Stemwall Width in. (mm)	Min. Edge Dist. in. (mm)	Min. End Dist. in. (mm)	Tension Load Based on Bond Strength			Tension Load Based on Steel Strength
						$f'_c \geq 2,000$ psi (13.8 MPa) Concrete			F1554 Grade 36
						Ultimate lb. (kN)	Std. Dev. lb. (kN)	Allowable lb. (kN)	Allowable lb. (kN)
5/8 (15.9)	3/4	9 1/2 (241.3)	6 (152.4)	1 3/4 (44.5)	5 (127.0)	10,720 (47.7)	1,559 (6.9)	2,680 (11.9)	5,875 (26.1)
5/8 (15.9)	3/4	12 (304.8)	6 (152.4)	1 3/4 (44.5)	5 (127.0)	16,150 (71.8)	260 (1.2)	4,040 (18.0)	5,875 (26.1)
7/8 (22.2)	1	12 1/2 (317.5)	8 (203.2)	1 3/4 (44.5)	5 (127.0)	17,000 (75.6)	303 (1.3)	4,250 (18.9)	11,500 (51.2)
7/8 (22.2)	1	15 1/2 (393.7)	8 (203.2)	1 3/4 (44.5)	5 (127.0)	23,340 (103.8)	762 (3.4)	5,835 (26.0)	11,500 (51.2)

1. Allowable load must be the lesser of the bond or steel strength.
2. The allowable loads listed under allowable bond are based on a safety factor of 4.0.
3. Refer to in-service temperature sensitivity chart on page 77 for allowable load adjustment for temperature.
4. Anchors are permitted to be used within fire-resistive construction, provided the anchors resist wind or seismic loads only. For use in fire-resistive construction, the anchors can also be permitted to be used to resist gravity loads, provided special consideration has been given to fire-exposure conditions.

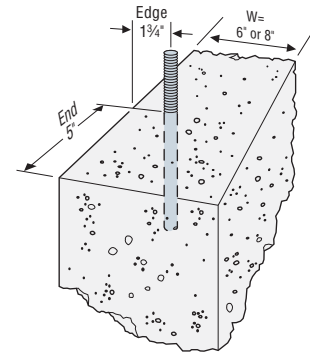

Edge and end distances for threaded rod in concrete foundation stemwall corner installation

* See page 12 for an explanation of the load table icons.

ET-HP® Design Information — Concrete

ET-HP® Allowable Tension Loads for Rebar Dowels in Normal-Weight Concrete

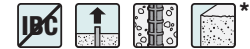

Rebar Size No. (mm)	Drill Bit Dia. in.	Embed. Depth in. (mm)	Critical Edge Dist. in. (mm)	Critical Spacing Dist. in. (mm)	Tension Load Based on Bond Strength						Tension Load Based on Steel Strength
					$f'_c \geq 2,000$ psi (13.8 MPa) Concrete			$f'_c \geq 4,000$ psi (27.6 MPa) Concrete			ASTM A615 Grade 60 Rebar
					Ultimate lb. (kN)	Std. Dev. lb. (kN)	Allowable lb. (kN)	Ultimate lb. (kN)	Std. Dev. lb. (kN)	Allowable lb. (kN)	Allowable lb. (kN)
#4 (12.7)	5/8	4 1/4 (108)	6 3/8 (162)	17 (432)	17,596 (78.3)	533 (2.4)	4,400 (19.6)	—	—	4,400 (19.6)	4,800 (21.4)
		6 (152)	9 (229)	24 (610)	—	—	—	20,250 (90.1)	263 (1.2)	5,060 (22.5)	
#5 (15.9)	3/4	5 (127)	7 1/2 (191)	20 (508)	25,427 (113.1)	1,899 (8.4)	6,355 (28.3)	—	—	6,355 (28.3)	7,440 (33.1)
		9 3/8 (238)	14 1/8 (359)	37 1/2 (953)	—	—	—	29,510 (131.3)	2,270 (10.1)	7,375 (32.8)	
#6 (19.1)	7/8	6 3/4 (171)	10 1/8 (257)	27 (686)	41,812 (186.0)	595 (2.6)	10,455 (46.5)	—	—	10,455 (46.5)	10,560 (47.0)
		11 1/4 (286)	16 7/8 (429)	45 (1,143)	—	—	—	44,210 (196.7)	1,227 (5.5)	11,050 (49.2)	
#7 (22.2)	1	7 3/4 (197)	11 5/8 (295)	31 (787)	50,241 (223.5)	2,995 (13.3)	12,560 (55.9)	—	—	12,560 (55.9)	14,400 (64.1)
		13 1/8 (333)	19 3/4 (502)	52 1/2 (1,334)	—	—	—	59,325 (263.9)	3,444 (15.3)	14,830 (66.0)	
#8 (25.4)	1 1/8	9 (229)	13 1/2 (343)	36 (914)	60,145 (267.5)	5,493 (24.4)	15,035 (66.9)	—	—	15,035 (66.9)	18,960 (84.3)
		12 (305)	18 (457)	48 (1,219)	—	—	—	—	—	18,260 (81.2)	
		15 (381)	22 1/2 (572)	60 (1,524)	—	—	—	85,970 (382.4)	17,965 (79.9)	21,490 (95.6)	
#9 (28.6)	1 1/4	9 (229)	13 1/2 (343)	36 (914)	—	—	15,035 (66.9)	—	—	15,035 (66.9)	24,000 (106.8)
		13 (330)	19 1/2 (495)	52 (1,321)	—	—	—	—	—	21,310 (94.8)	
		16 7/8 (429)	25 3/8 (645)	67 1/2 (1,715)	—	—	—	110,370 (491.0)	4,768 (21.2)	27,590 (122.7)	
#10 (31.8)	1 1/2	11 1/4 (286)	16 7/8 (429)	45 (1,143)	70,685 (314.4)	1,112 (4.9)	17,670 (78.6)	—	—	17,670 (78.6)	30,480 (135.6)
		15 (381)	22 1/2 (572)	60 (1,524)	—	—	—	—	—	23,960 (106.6)	
		18 3/4 (476)	28 1/8 (714)	75 (1,905)	—	—	—	120,976 (538.1)	6,706 (29.8)	30,245 (134.5)	
#11 (34.9)	1 5/8	12 3/8 (314)	18 5/8 (473)	49 1/2 (1,257)	78,422 (348.8)	4,603 (20.5)	19,605 (87.2)	—	—	19,605 (87.2)	37,440 (166.5)
		16 1/2 (419)	24 3/4 (629)	66 (1,676)	—	—	—	—	—	28,605 (127.2)	
		20 5/8 (524)	31 (787)	82 1/2 (2,096)	—	—	—	150,415 (669.1)	8,287 (36.9)	37,605 (167.3)	
#14 (44.5)	2	15 3/4 (400)	23 3/8 (600)	63 (1,600)	91,518 (407.1)	3,797 (16.9)	22,880 (101.8)	—	—	22,880 (101.8)	54,000 (240.2)

1. Allowable load must be the lesser of the bond or steel strength.

2. The allowable loads listed under allowable bond are based on a safety factor of 4.0.

3. Refer to allowable load-adjustment factors for spacing and edge distance on pages 84 and 85.

4. Refer to in-service temperature sensitivity chart on page 77 for allowable load adjustment for temperature.

5. Anchors are permitted to be used within fire-resistive construction, provided the anchors resist wind or seismic loads only.

For use in fire-resistive construction, the anchors can also be permitted to be used to resist gravity loads, provided special consideration has been given to fire-exposure conditions.

6. Anchors are not permitted to resist tension forces in overhead or wall installations unless proper consideration is given to fire-exposure and elevated-temperature conditions.

ET-HP® Design Information — Concrete

ET-HP® Allowable Shear Loads for Rebar Dowels in Normal-Weight Concrete

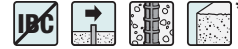

Rebar Size No. (mm)	Drill Bit Dia. in.	Embed. Depth in. (mm)	Critical Edge Dist. in. (mm)	Critical Spacing Dist. in. (mm)	Shear Load Based on Concrete Edge Distance			Shear Load Based on Steel Strength
					$f'_c \geq 2,500$ psi (17.2 MPa) Concrete			ASTM A615 Grade 60 Rebar
					Ultimate lb. (kN)	Std. Dev. lb. (kN)	Allowable lb. (kN)	Allowable lb. (kN)
#4 (12.7)	5/8	4 1/4 (108)	8 (203)	6 3/8 (162)	13,564 (60.3)	971 (4.3)	3,390 (15.1)	3,060 (13.6)
#5 (15.9)	3/4	5 (127)	10 (254)	7 1/2 (191)	20,914 (93.0)	3,034 (13.5)	5,230 (23.3)	4,740 (21.1)
#6 (19.1)	7/8	6 3/4 (171)	12 (305)	10 1/8 (257)	30,148 (134.1)	1,322 (5.9)	7,535 (33.5)	6,730 (29.9)
#7 (22.2)	1	7 3/4 (197)	14 (356)	11 5/8 (295)	39,838 (177.2)	1,854 (8.2)	9,960 (44.3)	9,180 (40.8)
#8 (25.4)	1 1/8	9 (229)	16 (406)	13 1/2 (343)	53,090 (236.2)	3,562 (15.8)	13,270 (59.0)	12,085 (53.8)
#9 (28.7)	1 1/4	10 1/8 (257)	18 (457)	15 1/4 (387)	63,818 (284.7)	3,671 (16.3)	15,955 (71.0)	15,300 (68.1)
#10 (32.3)	1 1/2	11 1/4 (286)	20 (508)	16 7/8 (429)	82,782 (368.2)	2,245 (10.0)	20,695 (92.1)	19,430 (86.4)
#11 (35.8)	1 5/8	12 3/8 (314)	22 (559)	18 5/8 (473)	96,056 (427.3)	3,671 (16.3)	24,015 (106.8)	23,865 (106.2)
#14 (43.0)	2	12 3/8 (314)	22 (559)	18 5/8 (473)	—	—	24,015 (106.8)	34,425 (153.1)

1. Allowable load must be the lesser of the load based on concrete edge distance or steel strength.
2. The allowable loads based on concrete edge distance are based on a safety factor of 4.0.
3. Refer to allowable load-adjustment factors for spacing and edge distance on pages 84 and 85.
4. Refer to in-service temperature sensitivity chart on page 77 for allowable load adjustment for temperature.
5. Anchors are permitted to be used within fire-resistive construction, provided the anchors resist wind or seismic loads only. For use in fire-resistive construction, the anchors can also be permitted to be used to resist gravity loads, provided special consideration has been given to fire-exposure conditions.

* See page 12 for an explanation of the load table icons.

ET-HP® Design Information — Masonry

ET-HP® Allowable Tension and Shear Loads for Threaded Rod and Rebar in the Face of Fully Grouted CMU Wall Construction^{1, 3, 4, 5, 6, 8, 9, 10, 11, 12}

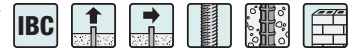

Diameter (in.) or Rebar Size No.	Drill Bit Diameter (in.)	Minimum Embedment ² (in.)	Allowable Load Based on Bond Strength ⁷ (lb.)	
			Tension Load	Shear Load
Threaded Rod Installed in the Face of CMU Wall				
3/8	1/2	3 3/8	1,425	845
1/2	5/8	4 1/2	1,425	1,470
5/8	3/4	5 5/8	1,560	1,835
3/4	7/8	6 1/2	1,560	2,050
Rebar Installed in the Face of CMU Wall				
#3	1/2	3 3/8	1,275	1,335
#4	5/8	4 1/2	1,435	1,355
#5	3/4	5 5/8	1,550	1,355

1. Allowable load shall be the lesser of the bond values shown in this table and steel values, shown on page 83.
2. Embedment depth shall be measured from the outside face of masonry wall.
3. Critical and minimum edge distance and spacing shall comply with the information on page 82. Figure 2 on page 82 illustrates critical and minimum edge and end distances.
4. Minimum allowable nominal width of CMU wall shall be 8 inches. The minimum allowable member thickness shall be no less than 1 1/2 times the actual anchor embedment.
5. No more than one anchor shall be permitted per masonry cell.
6. Anchors shall be permitted to be installed at any location in the face of the fully grouted masonry wall construction (cell, web, bed joint), except anchors shall not be installed within 1 1/2 inches of the head joint, as show in Figure 2 on page 82.
7. Tabulated allowable load values are for anchors installed in fully grouted masonry walls.
8. Tabulated allowable loads are based on a safety factor of 5.0.
9. Tabulated allowable load values shall be adjusted for increased base material temperatures in accordance with Figure 1 below, as applicable.
10. Threaded rod and rebar installed in fully grouted masonry walls with ET-HP® are permitted to resist dead, live, seismic and wind loads.
11. Threaded rod shall meet or exceed the tensile strength of ASTM F1554, Grade 36 steel, which is 58,000 psi.
12. For installations exposed to severe, moderate or negligible exterior weathering conditions, as defined in Figure 1 of ASTM C62, allowable tension loads shall be multiplied by 0.80.

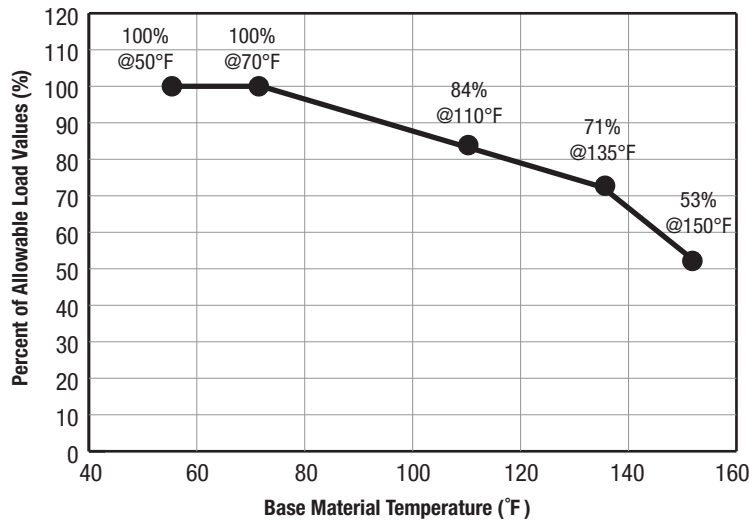
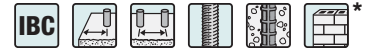

Figure 1. Load capacity based on in-service temperature for ET-HP® epoxy adhesive in the face of fully grouted CMU wall construction

* See page 12 for an explanation of the load table icons.

ET-HP® Design Information — Masonry

ET-HP® Edge Distance and Spacing Requirements and Allowable Load Reduction Factors — Threaded Rod and Rebar in the Face of Fully Grouted CMU Wall Construction^{2,7}



Adhesive Anchors

Rod Dia. (in.) or Rebar Size No.	Minimum Embed. Depth (in.)	Edge or End Distance ^{1,8}						Spacing ^{2,9}				
		Critical (Full Anchor Capacity) ³		Minimum (Reduced Anchor Capacity) ⁴				Critical (Full Anchor Capacity) ⁵		Minimum (Reduced Anchor Capacity) ⁶		
		Critical Edge or End Distance, C_{cr} (in.)	Allowable Load Reduction Factor	Minimum Edge or End Distance, C_{min} (in.)	Allowable Load Reduction Factor		Critical Spacing, S_{cr} (in.)	Allowable Load Reduction Factor	Minimum Spacing, S_{min} (in.)	Allowable Load Reduction Factor		
		Load Direction		Load Direction				Load Direction		Load Direction		
		Tension or Shear	Tension or Shear	Tension or Shear	Tension	Shear ¹⁰		Tension or Shear	Tension or Shear	Tension or Shear	Tension	Shear
					Perp.	Parallel						
3/8	3%	12	1.00	4	0.76	1.00	1.00	8	1.00	4	0.47	0.94
1/2	4 1/2	12	1.00	4	1.00	0.92	0.9	8	1.00	4	0.60	0.96
5/8	5%	12	1.00	4	1.00	0.55	0.86	8	1.00	4	0.72	0.98
3/4	6 1/2	12	1.00	4	1.00	0.55	0.86	8	1.00	4	0.85	1.00
#3	3%	12	1.00	4	0.96	0.86	1.00	8	1.00	4	0.37	0.92
#4	4 1/2	12	1.00	4	1.00	0.71	1.00	8	1.00	4	0.69	0.96
#5	5%	12	1.00	4	1.00	0.71	1.00	8	1.00	4	1.00	1.00

- Edge distance (C_{cr} or C_{min}) is the distance measured from anchor centerline to edge or end of CMU masonry wall. Refer to Figure 2 below for an illustration showing critical and minimum edge and end distances.
- Anchor spacing (S_{cr} or S_{min}) is the distance measured from centerline to centerline of two anchors.
- Critical edge distance, C_{cr} , is the least edge distance at which tabulated allowable load of an anchor is achieved where a load reduction factor equals 1.0 (no load reduction).
- Minimum edge distance, C_{min} , is the least edge distance where an anchor has an allowable load capacity which shall be determined by multiplying the allowable loads assigned to anchors installed at critical edge distance, C_{cr} , by the load reduction factors shown above.
- Critical spacing, S_{cr} , is the least anchor spacing at which tabulated allowable load of an anchor is achieved such that anchor performance is not influenced by adjacent anchors.
- Minimum spacing, S_{min} , is the least spacing where an anchors has an allowable load capacity, which shall be determined by multiplying the allowable loads assigned to anchors installed at critical spacing distance, S_{cr} , by the load reduction factors shown above.
- Reduction factors are cumulative. Multiple reduction factors for more than one spacing or edge or end distance shall be calculated separately and multiplied.
- Load reduction factor for anchors loaded in tension or shear with edge distances between critical and minimum shall be obtained by linear interpolation.
- Load reduction factor for anchors loaded in tension with spacing between critical and minimum shall be obtained by linear interpolation.
- Perpendicular shear loads act towards the edge or end. Parallel shear loads act parallel to the edge or end (see Figure 3 below). Perpendicular and parallel shear load reduction factors are cumulative when the anchor is located between the critical minimum edge and end distance.

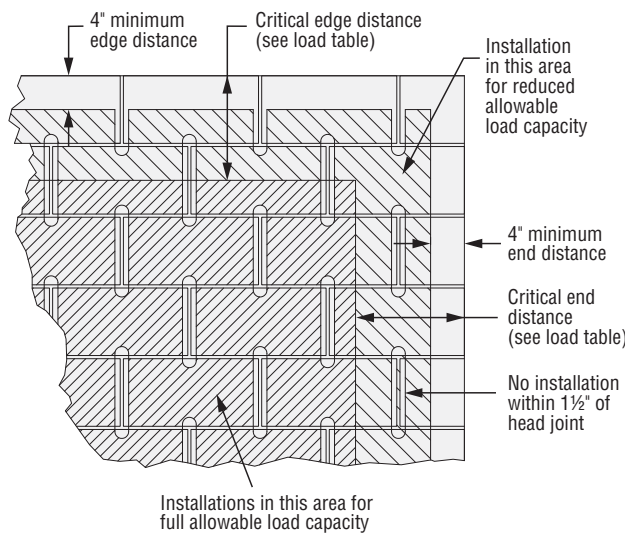

Figure 2. Allowable anchor placement in grouted CMU face shell

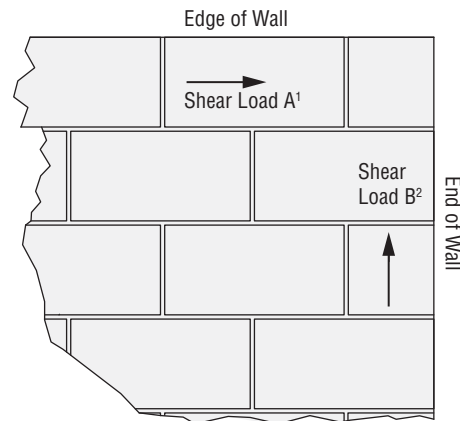

Figure 3. Anchor placement in grouted CMU mortar "T" joint

- Direction of Shear Load A is parallel to edge of wall and perpendicular to end of wall.
- Direction of Shear Load B is parallel to end of wall and perpendicular to edge of wall.

* See page 12 for an explanation of the load table icons.

ET-HP® Design Information — Masonry

ET-HP® Allowable Tension and Shear Loads — Threaded Rod Based on Steel Strength¹



Threaded Rod Diameter (in.)	Tensile Stress Area (in. ²)	Tension Load Based on Steel Strength ² (lb.)				Shear Load Based on Steel Strength ² (lb.)			
		ASTM F1554 Grade 36 ⁴	ASTM A193 Grade B7 ⁶	Stainless Steel		ASTM F1554 Grade 36 ⁴	ASTMA 193 Grade B7 ⁶	Stainless Steel	
				ASTM A193 Grade B6 ⁵	ASTM A193 Grades B8 and B8M ⁷			ASTM A193 Grade B6 ⁵	ASTM A193 Grades B8 and B8M ⁷
3/8	0.078	1,495	3,220	2,830	1,930	770	1,660	1,460	995
1/2	0.142	2,720	5,860	5,155	3,515	1,400	3,020	2,655	1,810
5/8	0.226	4,325	9,325	8,205	5,595	2,230	4,805	4,225	2,880
3/4	0.334	6,395	13,780	12,125	8,265	3,295	7,100	6,245	4,260

- Allowable load shall be the lesser of bond values given on page 81 and steel values in the table above.
- Allowable Tension Steel Strength is based on the following equation: $F_v = 0.33 \times F_u \times \text{Tensile Stress Area}$.
- Allowable Shear Steel Strength is based on the following equation: $F_v = 0.17 \times F_u \times \text{Tensile Stress Area}$.
- Minimum specified tensile strength ($F_u = 58,000$ psi) of ASTM F1554, Grade 36 used to calculate allowable steel strength.
- Minimum specified tensile strength ($F_u = 110,000$ psi) of ASTM A193, Grade B6 used to calculate allowable steel strength.
- Minimum specified tensile strength ($F_u = 125,000$ psi) of ASTM A193, Grade B7 used to calculate allowable steel strength.
- Minimum specified tensile strength ($F_u = 75,000$ psi) of ASTM A193, Grades B8 and B8M used to calculate allowable steel strength.

ET-HP® Allowable Tension and Shear Loads — Deformed Reinforcing Bar Based on Steel Strength¹



Rebar Size	Tensile Stress Area (in. ²)	Tension Load (lb.)		Shear Load (lb.)	
		Based on Steel Strength		Based on Steel Strength	
		ASTM A615 Grade 40 ²	ASTM A615 Grade 60 ³	ASTM A615 Grade 40 ^{4,5}	ASTM A615 Grade 60 ^{4,6}
#3	0.11	2,200	2,640	1,310	1,685
#4	0.20	4,000	4,800	2,380	3,060
#5	0.31	6,200	7,400	3,690	4,745

- Allowable load shall be the lesser of bond values given on page 81 and steel values in the table above.
- Allowable Tension Steel Strength is based on AC58 Section 3.3.3 (20,000 psi x tensile stress area) for Grade 40 rebar.
- Allowable Tension Steel Strength is based on AC58 Section 3.3.3 (24,000 psi x tensile stress area) for Grade 60 rebar.
- Allowable Shear Steel Strength is based on AC58 Section 3.3.3 ($F_v = 0.17 \times F_u \times \text{Tensile Stress Area}$).
- $F_u = 70,000$ psi for Grade 40 rebar.
- $F_u = 90,000$ psi for Grade 60 rebar.

ET-HP® Allowable Tension and Shear Loads for Installations in Unreinforced Brick Masonry Walls — Minimum URM Wall Thickness is 13" (3 wythes thick)



Rod Dia. in. (mm)	Drill Bit Dia. in.	Embed. Depth in. (mm)	Min. Edge/End Dist. in. (mm)	Min. Vertical Spacing Dist. in. (mm)	Min. Horiz. Spacing Dist. in. (mm)	Tension Load Based on URM Strength		Shear Load Based on URM Strength	
						Minimum Net Mortar Strength = 50 psi		Minimum Net Mortar Strength = 50 psi	
						Allowable lb. (kN)		Allowable lb. (kN)	
Configuration A (Simpson Strong-Tie® ETS or ETSP Screen Tube Required)									
3/4 (19.1)	1	8 (203)	24 (610)	18 (457)	18 (457)	—	—	1,000 (4.4)	1,000 (4.4)
Configuration B (Simpson Strong-Tie® ETS or ETSP Screen Tube Required)									
3/4 (19.1)	1	13 (330)	16 (406)	18 (457)	24 (610)	1,200 (5.3)	1,200 (5.3)	1,000 (4.4)	1,000 (4.4)
Configuration C (Simpson Strong-Tie® ETS Screen Tube and AST Steel Sleeve Required)									
5/8 (15.9)	1	**	24 (610)	18 (457)	18 (457)	1,200 (5.3)	1,200 (5.3)	750 (3.3)	750 (3.3)

- Threaded rods must comply with ASTM F1554 Grade 36 minimum.
- All holes are drilled with a 1"-diameter carbide-tipped drill bit with the drill set in the rotation-only mode.
- The unreinforced brick walls must have a minimum thickness of 13 inches (three wythes of brick).
- The allowable load is applicable only where in-place shear tests indicate minimum net mortar strength of 50 psi.
- The allowable load for Configuration B and C anchors subjected to a combined tension and shear load is determined by assuming a straight-line relationship between allowable tension and shear.
- The anchors installed in unreinforced brick walls are limited to resisting seismic or wind forces only.
- Configuration A has a straight threaded rod or rebar embedded 8 inches into the wall with a 3/8"-diameter by 8-inch-long screen tube (part # ETS758 or ETS758P). This configuration is designed to resist shear loads only.
- Configuration B has a 3/4" threaded rod bent and installed at a 22.5-degree angle and installed 13 inches into the wall, to within 1-inch (maximum) of the exterior wall surface. This configuration is designed to resist tension and shear loads. The pre-bent threaded rod is installed with a 3/8" diameter by 13-inch-long screen tube (part # ETS7513 or ETS7513P).
- Configuration C is designed to resist tension and shear forces. It consists of a 5/8"-diameter, ASTM F1554 Grade 36 threaded rod and an 8"-long sleeve (part # AST800) and a 3/8"-diameter by 8-inch-long screen tube (part # ETS758). The steel sleeve has a plastic plug in one end. A 6" by 6" by 3/8" thick ASTM A 36 steel plate is located on the back face of the wall.
- Special inspection requirements are determined by local jurisdiction and must be confirmed by the local building official.
- Refer to in-service temperature sensitivity chart for allowable load adjustment for temperature.

* See page 12 for an explanation of the load table icons.

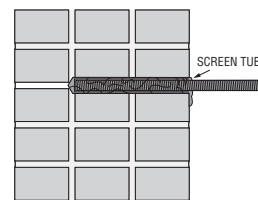

Configuration A (Shear)

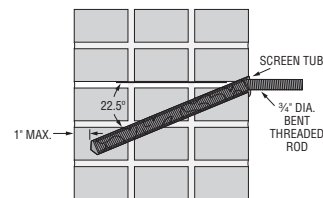

Configuration B (Tension & Shear)

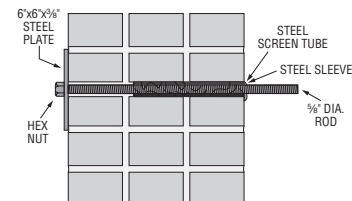

Configuration C (Tension & Shear)

Installation Instructions for Configuration C

- Drill hole perpendicular to the wall to a depth of 8" with a 1"-diameter carbide-tipped drill bit (rotation-only mode).
- Clean hole with oil-free compressed air and a nylon brush.
- Fill 8" steel screen tube with mixed adhesive and insert into hole.
- Insert steel sleeve slowly into screen tube (adhesive will displace).
- Allow adhesive to cure (see cure schedule).
- Drill through plastic plug in (inside) end of steel sleeve with 5/8" bit.
- Drill completely through the wall with 5/8" carbide-tipped concrete drill bit (rotation-only mode).
- Insert 5/8" rod through hole and attach metal plate and nut.

ET-HP® Design Information — Concrete

ET-HP® Allowable Load-Adjustment Factors in Normal-Weight Concrete:
Edge Distance, Tension and Shear Loads

How to use these charts

1. The following tables are for reduced edge distance.
2. Locate the anchor size to be used for either a tension and/or shear load application.
3. Locate the embedment (E) at which the anchor is to be installed.
4. Locate the edge distance (c_{act}) at which the anchor is to be installed.

5. The load-adjustment factor (f_c) is the intersection of the row and column.
6. Multiply the allowable load by the applicable load-adjustment factor.
7. Reduction factors for multiple edges are multiplied together.
8. Adjustment factors do not apply to allowable steel strength values.
9. Adjustment factors are to be applied to allowable tension load based on bond strength values or allowable Shear Load Based on Concrete Edge Distance values only.

Edge Distance Tension (f_c)

Edge Dist. (in.)	Dia. Rebar	#4		#5		#6		#7		#8		#9		#10		#11		#14		
		E	3 1/2	4 1/4	6	5	9 5/8	6 3/4	11 1/4	7 3/4	13 1/8	9	15	9	16 7/8	10 1/8	11 1/4	18 3/4	12 3/8	20 5/8
1 3/4	c_{cr}	5 1/4	6 3/8	9	7 1/2	14 1/8	10 1/8	16 7/8	11 5/8	19 3/4	13 1/2	22 1/2	13 1/2	25 3/8	15 1/4	16 7/8	28 1/8	18 5/8	31	23 5/8
	c_{min}	1 3/4	1 3/4	1 3/4	1 3/4	1 3/4	1 3/4	1 3/4	1 3/4	1 3/4	1 3/4	1 3/4	2 3/4	2 3/4	2 3/4	2 3/4	2 3/4	2 3/4	2 3/4	2 3/4
	f_{cmin}	0.50	0.50	0.59	0.50	0.64	0.50	0.57	0.50	0.52	0.50	0.47	0.50	0.47	0.58	0.58	0.51	0.58	0.51	0.58
2 3/4		0.50	0.50	0.59	0.50	0.64	0.50	0.57	0.50	0.52	0.50	0.47								
3		0.64	0.61	0.65	0.59	0.67	0.56	0.60	0.55	0.55	0.55	0.50	0.51	0.48	0.59	0.59	0.51	0.59	0.51	0.59
4		0.68	0.64	0.66	0.61	0.68	0.57	0.61	0.56	0.55	0.55	0.50	0.50	0.48	0.59	0.59	0.51	0.59	0.51	0.59
5		0.82	0.74	0.72	0.70	0.71	0.63	0.63	0.61	0.58	0.60	0.53	0.56	0.50	0.62	0.62	0.53	0.61	0.53	0.61
6		0.96	0.85	0.77	0.78	0.73	0.69	0.66	0.66	0.61	0.64	0.55	0.60	0.52	0.66	0.65	0.55	0.64	0.55	0.63
7		1.00	0.96	0.83	0.87	0.76	0.75	0.69	0.72	0.63	0.68	0.58	0.65	0.55	0.69	0.68	0.57	0.67	0.57	0.65
8			1.00	0.89	0.96	0.79	0.81	0.72	0.77	0.66	0.72	0.60	0.70	0.57	0.72	0.71	0.59	0.69	0.58	0.67
9				0.94	1.00	0.82	0.87	0.75	0.82	0.69	0.77	0.63	0.74	0.59	0.76	0.74	0.61	0.72	0.60	0.69
10					1.00	0.85	0.93	0.78	0.87	0.71	0.81	0.66	0.79	0.62	0.79	0.77	0.63	0.75	0.62	0.71
12						0.88	0.99	0.80	0.92	0.74	0.85	0.68	0.84	0.64	0.82	0.80	0.65	0.77	0.64	0.73
14						0.94	1.00	0.86	1.00	0.79	0.94	0.73	0.93	0.69	0.89	0.86	0.69	0.82	0.67	0.77
16							1.00	0.92		0.85	1.00	0.78	1.00	0.73	0.96	0.91	0.73	0.88	0.71	0.81
18								0.98		0.90		0.83		0.78	1.00	0.97	0.77	0.93	0.74	0.85
20								1.00		0.95		0.89		0.83		1.00	0.80	0.98	0.77	0.89
22									1.00		0.94		0.87			0.84	1.00	0.81	0.93	0.93
24										0.99		0.92				0.88		0.84	0.97	0.97
26										1.00		0.97				0.92		0.88	1.00	1.00
28													1.00				0.96		0.91	0.91
30																1.00			0.95	0.95
32																				0.98
																				1.00

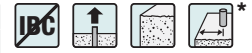

See notes below.

Edge Distance Shear (f_c)

Edge Dist. (in.)	Dia. Rebar	#4		#5		#6		#7		#8		#9		#10		#11		#14	
		E	3 1/2	4 1/4	5	5	6 3/4	6 3/4	7 3/4	7 3/4	9	9	10 1/8	10 1/8	11 1/4	11 1/4	12 3/8	12 3/8	
1 3/4	c_{cr}	5 1/4	6 3/8	8	7 1/2	10	10 1/8	12	11 5/8	14	13 1/2	16	18	15 1/4	16 7/8	20	22	22	
	c_{min}	1 3/4	1 3/4	1 3/4	1 3/4	1 3/4	1 3/4	1 3/4	1 3/4	1 3/4	1 3/4	2 3/4	2 3/4	2 3/4	2 3/4	2 3/4	2 3/4	2 3/4	
	f_{cmin}	0.29	0.20	0.16	0.13	0.10	0.13	0.10	0.13	0.09	0.08	0.08							
2 3/4		0.29	0.20	0.16	0.13	0.10	0.13	0.10	0.13	0.09	0.08								
3		0.49	0.37	0.29	0.28	0.21	0.23	0.19	0.22	0.16	0.14	0.08	0.14	0.14	0.14	0.14	0.14	0.14	
4		0.54	0.42	0.33	0.32	0.24	0.26	0.21	0.24	0.18	0.18	0.16	0.10	0.16	0.16	0.15	0.15	0.15	
5		0.75	0.59	0.46	0.47	0.35	0.36	0.30	0.33	0.26	0.26	0.23	0.16	0.23	0.22	0.20	0.20	0.20	
6		0.95	0.76	0.60	0.62	0.45	0.47	0.39	0.42	0.33	0.33	0.29	0.22	0.29	0.28	0.25	0.24	0.24	
7		1.00	0.94	0.73	0.77	0.56	0.57	0.47	0.50	0.41	0.41	0.35	0.28	0.36	0.34	0.30	0.29	0.29	
8			1.00	0.87	0.92	0.67	0.68	0.56	0.59	0.48	0.49	0.42	0.34	0.43	0.40	0.35	0.33	0.33	
9				1.00	1.00	0.78	0.78	0.65	0.68	0.55	0.57	0.48	0.40	0.50	0.46	0.40	0.37	0.37	
10						0.89	0.88	0.74	0.77	0.63	0.65	0.55	0.46	0.57	0.52	0.45	0.42	0.42	
11						1.00	0.99	0.82	0.86	0.70	0.73	0.61	0.52	0.64	0.58	0.50	0.46	0.46	
12							1.00	0.91	0.94	0.78	0.80	0.68	0.58	0.71	0.64	0.55	0.51	0.51	
13								1.00	1.00	0.85	0.88	0.74	0.64	0.78	0.70	0.60	0.55	0.55	
14										0.93	0.96	0.81	0.70	0.85	0.76	0.65	0.60	0.60	
15										1.00	1.00	0.87	0.76	0.91	0.82	0.70	0.64	0.64	
16											0.94	0.82	0.98	0.89	0.75	0.69	0.69	0.69	
18											1.00	0.88	1.00	0.95	0.80	0.73	0.73	0.73	
20												1.00			1.00	0.90	0.82	0.82	
22																1.00	0.91	0.91	
																	1.00	1.00	1.00

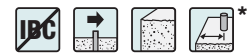

1. E = Embedment depth (inches).
2. c_{act} = actual edge distance at which anchor is installed (inches).
3. c_{cr} = critical edge distance for 100% load (inches).
4. c_{min} = minimum edge distance for reduced load (inches).

5. f_c = adjustment factor for allowable load at actual edge distance.
6. f_{ccr} = adjustment factor for allowable load at critical edge distance. f_{ccr} is always = 1.00.
7. f_{cmin} = adjustment factor for allowable load at minimum edge distance.
8. $f_c = f_{cmin} + [(1 - f_{cmin})(c_{act} - c_{min}) / (c_{cr} - c_{min})]$.

* See page 12 for an explanation of the load table icons.

ET-HP® Design Information — Concrete

ET-HP® Allowable Load-Adjustment Factors in Normal-Weight Concrete: Spacing, Tension and Shear Loads

How to use these charts

- The following tables are for reduced spacing.
- Locate the anchor size to be used for either a tension and/or shear load application.
- Locate the embedment (E) at which the anchor is to be installed.
- Locate the spacing (S_{act}) at which the anchor is to be installed.
- The load-adjustment factor (f_s) is the intersection of the row and column.
- Multiply the allowable load by the applicable load-adjustment factor.
- Reduction factors for multiple spacings are multiplied together.
- Adjustment factors do not apply to allowable steel strength values.
- Adjustment factors are to be applied to allowable Tension Load Based on Bond Strength values or allowable Shear Load Based on Concrete Edge Distance values only.

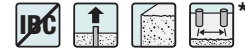

Spacing Tension (f_s)

S_{act} (in.)	Dia.	3/8	1/2	5/8	3/4	7/8	1	1 1/8	1 1/4	1 3/8	1 1/2	1 5/8	1 3/4	1 7/8	2				
	Rebar	#4	#5	#6	#7	#8	#9	#10	#11	#14									
E	3 1/2	4 1/4	5	6	7 3/4	9	10 1/2	11 1/4	12 3/8	13 1/2	15	16 7/8	18 3/4	20 5/8	22 1/2				
S_{cr}	14	17	24	20	37 1/2	27	45	31	52 1/2	36	60	36	67 1/2	40 1/2	45	75	49 1/2	82 1/2	63
S_{min}	1 3/4	2 1/8	3	2 1/2	4 3/4	3 3/8	5 5/8	3 7/8	6 5/8	4 1/2	7 1/2	4 1/2	8 1/2	5 1/8	5 5/8	9 3/8	6 1/4	10 3/8	7 7/8
f_{smin}	0.89	0.89	0.89	0.89	0.89	0.89	0.89	0.89	0.89	0.89	0.89	0.89	0.89	0.89	0.89	0.89	0.89	0.89	0.89
1 3/4	0.89																		
2	0.89																		
4	0.91	0.90	0.90	0.90		0.89		0.89											
6	0.93	0.92	0.91	0.91	0.89	0.90	0.89	0.90		0.90		0.90		0.89	0.89				
8	0.95	0.93	0.92	0.92	0.90	0.91	0.90	0.91	0.89	0.90	0.89	0.90		0.90	0.90		0.89		0.89
10	0.96	0.95	0.93	0.94	0.91	0.92	0.90	0.91	0.90	0.91	0.90	0.91	0.89	0.91	0.90	0.89	0.90	0.90	0.89
12	0.98	0.96	0.94	0.95	0.91	0.93	0.91	0.92	0.90	0.92	0.90	0.92	0.90	0.91	0.91	0.89	0.90	0.89	0.90
14	1.00	0.98	0.95	0.96	0.92	0.94	0.91	0.93	0.91	0.92	0.90	0.92	0.90	0.92	0.91	0.90	0.89	0.90	0.90
16		0.99	0.96	0.97	0.93	0.95	0.92	0.94	0.91	0.93	0.91	0.93	0.90	0.92	0.91	0.90	0.91	0.90	0.91
18		1.00	0.97	0.99	0.93	0.96	0.92	0.95	0.92	0.94	0.91	0.94	0.91	0.93	0.92	0.90	0.92	0.90	0.91
20			0.98	1.00	0.94	0.97	0.93	0.96	0.92	0.94	0.92	0.94	0.91	0.94	0.93	0.91	0.92	0.90	0.91
24			1.00		0.95	0.99	0.94	0.97	0.93	0.96	0.92	0.96	0.92	0.95	0.94	0.91	0.94	0.91	0.92
28					0.97	1.00	0.95	0.99	0.94	0.97	0.93	0.97	0.93	0.96	0.95	0.92	0.95	0.92	0.93
32					0.98		0.96	1.00	0.95	0.99	0.94	0.99	0.93	0.97	0.96	0.93	0.96	0.92	0.94
36					0.99		0.97		0.96	1.00	0.95	1.00	0.94	0.99	0.97	0.93	0.97	0.93	0.95
40					1.00		0.99		0.97		0.96		0.95	1.00	0.99	0.94	0.98	0.94	0.95
45						1.00		0.98		0.97		0.96		1.00	0.95	0.99	0.94	0.96	
50							0.99		0.98		0.97			0.96	1.00	0.95	0.97		
55							1.00		0.99		0.98			0.97		0.96	0.98		
60								1.00	0.99		0.98			0.97		0.97	0.99		
65									1.00		0.99			0.98		0.97	1.00		
70											1.00			0.99		0.98			
75													1.00		0.99				
82 1/2																1.00			

See Notes Below.

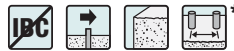

Spacing Shear (f_s)

S_{act} (in.)	Dia.	3/8	1/2	5/8	3/4	7/8	1	1 1/8	1 1/4	1 3/8	1 1/2
	Rebar	#4	#5	#6	#7	#8	#9	#10	#11	#14	
E	3 1/2	4 1/4	5	6 3/4	7 3/4	9	10 1/2	11 1/4	12 3/8	13 1/2	15
S_{cr}	5 1/4	6 3/8	7 1/2	10 1/8	11 1/8	13 1/2	15 1/4	16 7/8	18 5/8	18 5/8	21 1/2
S_{min}	1 3/4	2 1/8	2 1/2	3 3/8	3 7/8	4 1/2	5 1/8	5 5/8	6 1/4	6 1/4	7 1/2
f_{smin}	0.83	0.83	0.83	0.83	0.83	0.83	0.83	0.83	0.83	0.83	0.83
1 3/4	0.83										
2	0.84										
3	0.89	0.87	0.85								
4	0.94	0.91	0.88	0.85	0.83						
5	0.99	0.95	0.92	0.87	0.85	0.84					
6	1.00	0.99	0.95	0.90	0.88	0.86	0.84	0.84			
7		1.00	0.98	0.92	0.90	0.88	0.86	0.85	0.84	0.84	
8			1.00	0.95	0.92	0.90	0.88	0.87	0.85	0.85	
9				0.97	0.94	0.92	0.90	0.88	0.87	0.87	
10				1.00	0.96	0.93	0.91	0.90	0.88	0.88	
12					1.00	0.97	0.95	0.93	0.91	0.91	
14						1.00	0.98	0.96	0.94	0.94	
16							1.00	0.99	0.96	0.96	
18								1.00	0.99	0.99	
20									1.00	1.00	

- E = Embedment depth (inches).
- S_{act} = actual spacing distance at which anchors are installed (inches).
- S_{cr} = critical spacing distance for 100% load (inches).
- S_{min} = minimum spacing distance for reduced load (inches).
- f_s = adjustment factor for allowable load at actual spacing distance.
- $f_{s_{cr}}$ = adjustment factor for allowable load at critical spacing distance. $f_{s_{cr}}$ is always = 1.00.
- $f_{s_{min}}$ = adjustment factor for allowable load at minimum spacing distance.
- $f_s = f_{s_{min}} + [(1 - f_{s_{min}}) (S_{act} - S_{min}) / (S_{cr} - S_{min})]$.

* See page 12 for an explanation of the load table icons.

AT Acrylic Adhesive

AT is a high-strength, acrylic-based adhesive anchoring system, formulated for use as a high-strength anchor-grouting material in a wide range of temperature conditions. It is a two-part system, with the resin and initiator being simultaneously dispensed and mixed through the mixing nozzle.

Features

- Code listed under the IBC/IRC for URM per ICC-ES ESR-1958
- Cure times – 24 hours at 0°F, 1 hour at 60°F
- Non-sag gel formulation ideal for horizontal, vertical and overhead applications
- Easy hole-cleaning procedure – no power-brushing required
- Suitable for use in damp or wet anchor sites
- When properly mixed, adhesive will be a uniform gray color
- Available in 9.6 oz., 12.5 oz. and 30 oz. cartridges for application versatility
- Manufactured in the USA using global materials

Applications

- Threaded rod anchoring and rebar doweling into concrete, masonry and URM (red brick)
- Multiple DOT listings – refer to www.strongtie.com/DOT for current approvals

Codes: ICC-ES ESR-1958 (URM); AASHTO M-235 and ASTM C881 (Type I and IV, Grade 3, Class A, B and C – except AT adhesive is a non-epoxy formulated for fast cure time); multiple DOT listings (refer to strongtie.com/DOT).

Chemical Resistance

See pages 320–321.

Installation and Application Instructions

(See also pages 124–127.)

- Surfaces to receive adhesive must be clean.
- Base material temperature must be 0°F or above at the time of installation.
- For information on installations below 0°F, contact Simpson Strong-Tie.
- Mixed material in nozzle can harden in 5–7 minutes at temperatures of 70°F and above.

Design Example

See page 324.

Suggested Specifications

See www.strongtie.com for more information.



AT Adhesive

AT Acrylic Adhesive

Test Criteria

Anchors installed with AT adhesive have been tested in accordance with ICC-ES *Acceptance Criteria for Anchors in Unreinforced Masonry Elements (AC60)*.

Property	Test Method	Result*
Consistency	ASTM C881	Non-sag/thixotropic paste
Heat deflection	ASTM D648	142°F (61°C)
Bond strength (moist cure, 60°F)	ASTM C882	2,960 psi (2 days) 3,567 psi (14 days)
Water absorption	ASTM D570	0.25% (24 hours)
Compressive yield strength (cured 60°F)	ASTM D695	10,930 psi (7 days)
Compressive modulus (cured 60°F)	ASTM D695	502,330 psi (7 days)
Shore D hardness	ASTM D2240	91
Gel time	ASTM C881	5 minutes
VOC	ASTM D2369	25 g/L
Shrinkage coefficient	ASTM D2566	0.004 in./in.

*Material and curing conditions: 73 ± 2°F, unless otherwise noted.

AT Adhesive Cartridge Systems

Model No.	Capacity (ounces)	Cartridge Type	Carton Quantity	Dispensing Tools	Mixing Nozzle
AT10	9.6	Single	12	CDT10S	AMN19Q
AT13	12.5	Side-by-side	10	ADT813S	
AT30	30	Side-by-side	5	ADT30S ADTA30CKT ADTA30P	

1. Cartridge estimation guidelines are available at www.strongtie.com/apps.
2. Detailed information on dispensing tools, mixing nozzles and other adhesive accessories is available on pages 128 through 135, or at www.strongtie.com.
3. Use only Simpson Strong-Tie® mixing nozzles in accordance with Simpson Strong-Tie instructions. Modification or improper use of mixing nozzle may impair AT adhesive performance.

In-Service Temperature Sensitivity

Base Material Temperature		Percent Allowable Load for $T_{inst} = 0^{\circ}\text{F}$	Percent Allowable Load for $T_{inst} \geq 70^{\circ}\text{F}$
°F	°C		
0	-18	100%	100%
32	0	100%	100%
70	21	100%	100%
110	43	82%	82%
135	57	74%	82%
150	66	38%	65%
180	82	22%	28%

1. Refer to in-service temperature sensitivity chart for allowable bond strength reduction for in-service temperature. See page 319.
2. T_{inst} is the base material temperature during installation and curing of the adhesive.
3. Percent allowable load for $T_{inst} = 0^{\circ}\text{F}$ (-18°C) is to be used for T_{inst} between 0°F (-18°C) and 70°F (21°C).
4. Percent allowable load may be linearly interpolated for intermediate base material in-service temperatures.
5. $^{\circ}\text{C} = (^{\circ}\text{F} - 32) / 1.8$

Cure Schedule

Base Material Temperature		Cure Time (hrs.)
°F	°C	
0	-18	24
25	-4	8
40	4	4
60	16	1
70	21	30 min.
100	38	20 min.

AT Design Information — Concrete

AT Allowable Tension Loads for Threaded Rod Anchors in Normal-Weight Concrete (continued on next page)

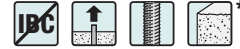

Adhesive Anchors

Rod Dia. in. (mm)	Drill Bit Dia. in.	Embed. Depth in. (mm)	Critical Edge Dist. in. (mm)	Critical Spacing Dist. in. (mm)	Tension Load Based on Bond Strength			Tension Load Based on Steel Strength		
					f' _c ≥ 2,000 psi (13.8 MPa) Concrete			F1554 Grade 36	A193 GR B7	F593 304SS
					Ultimate lb. (kN)	Std. Dev. lb. (kN)	Allowable lb. (kN)	Allowable lb. (kN)	Allowable lb. (kN)	Allowable lb. (kN)
3/8 (9.5)	7/16	1 3/4 (44)	2 5/8 (67)	7 (178)	3,362 (15.0)	99 (0.4)	840 (3.7)	2,105 (9.4)	4,535 (20.2)	3,630 (16.1)
		3 1/2 (89)	5 1/4 (133)	6 1/8 (156)	8,937 (39.8)	314 (1.4)	2,235 (9.9)			
		4 1/2 (114)	6 3/4 (171)	18 (457)	10,411 (46.3)	525 (2.3)	2,605 (11.6)			
1/2 (12.7)	9/16	2 1/8 (54)	3 3/16 (81)	8 1/2 (216)	5,252 (23.4)	501 (2.2)	1,315 (5.8)	3,750 (16.7)	8,080 (35.9)	6,470 (28.8)
		4 1/4 (108)	6 3/8 (162)	7 1/2 (191)	16,668 (74.1)	822 (3.7)	4,165 (18.5)			
		6 (152)	9 (229)	24 (610)	19,182 (85.3)	331 (1.5)	4,795 (21.3)			
5/8 (15.9)	1 1/16	2 1/2 (64)	3 3/4 (95)	10 (254)	8,495 (37.8)	561 (2.5)	2,125 (9.5)	5,875 (26.1)	12,660 (56.3)	10,120 (45.0)
		4 (102)	5 5/8 (143)	16 (406)	—	—	4,315 (19.2)			
		5 1/2 (140)	7 1/2 (191)	9 5/8 (244)	26,025 (115.8)	1,866 (8.3)	6,505 (28.9)			
		7 7/16 (189)	10 7/8 (276)	29 3/4 (756)	—	—	7,215 (32.1)			
		9 3/8 (238)	14 1/8 (359)	37 1/2 (953)	31,683 (140.9)	1,571 (7.0)	7,920 (35.2)			

See notes on next page.

3/4" – 1 1/4" diameters on next page →

* See page 12 for an explanation of the load table icons.

AT Design Information — Concrete

AT Allowable Tension Loads for Threaded Rod Anchors in Normal-Weight Concrete (continued from previous page)

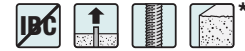

Rod Dia. in. (mm)	Drill Bit Dia. in.	Embed. Depth in. (mm)	Critical Edge Dist. in. (mm)	Critical Spacing Dist. in. (mm)	Tension Load Based on Bond Strength			Tension Load Based on Steel Strength		
					f _c ≥ 2,000 psi (13.8 MPa) Concrete			F1554 Grade 36	A193 GR B7	F593 304SS
					Ultimate lb. (kN)	Std. Dev. lb. (kN)	Allowable lb. (kN)	Allowable lb. (kN)	Allowable lb. (kN)	Allowable lb. (kN)
¾ (19.1)	1⅜	3⅝ (86)	5⅞ (129)	13½ (343)	12,991 (57.8)	725 (3.2)	3,250 (14.5)	8,460 (37.6)	18,230 (81.1)	12,400 (55.2)
		5⅞ (129)	7⅝ (194)	20¼ (514)	—	—	6,330 (28.2)			
		6¾ (171)	10⅞ (257)	11⅞ (302)	37,616 (167.3)	1,817 (8.1)	9,405 (41.8)			
		9 (229)	13½ (343)	36 (914)	—	—	10,000 (44.5)			
		11¼ (286)	16⅞ (429)	45 (1143)	42,381 (188.5)	683 (3.0)	10,595 (47.1)			
7/8 (22.2)	1	3⅞ (98)	5⅞ (148)	15½ (394)	14,206 (63.2)	457 (2.0)	3,550 (15.8)	11,500 (51.2)	24,785 (110.2)	16,860 (75.0)
		5⅞ (148)	8¾ (222)	23¼ (591)	—	—	7,130 (31.7)			
		7¾ (197)	11⅞ (295)	13⅞ (346)	42,848 (190.6)	3,155 (14.0)	10,710 (47.6)			
		10⅞ (265)	15⅞ (397)	41¼ (1060)	—	—	12,250 (54.5)			
		13⅞ (333)	19⅞ (498)	52½ (1334)	55,148 (245.3)	5,673 (25.2)	13,785 (61.3)			
1 (25.4)	1⅞	4½ (114)	6¾ (171)	18 (457)	20,797 (92.5)	1,763 (7.8)	5,200 (23.1)	15,025 (66.8)	32,380 (144.0)	22,020 (97.9)
		6¾ (171)	10⅞ (257)	27 (686)	—	—	10,165 (45.2)			
		9 (229)	13½ (343)	15¼ (400)	60,504 (269.1)	2,065 (9.2)	15,125 (67.3)			
		12 (305)	18 (457)	48 (1219)	—	—	17,880 (79.5)			
		15 (381)	22½ (572)	60 (1524)	82,529 (367.1)	5,146 (22.9)	20,630 (91.8)			
1⅞ (28.6)	1⅞	5⅞ (130)	7¾ (197)	20½ (521)	26,600 (118.3)	—	6,650 (29.6)	19,025 (84.6)	41,000 (182.4)	27,880 (124.0)
		7⅞ (194)	11½ (292)	30½ (775)	—	—	11,780 (52.4)			
		10⅞ (257)	15¼ (387)	17¼ (451)	67,600 (300.7)	—	16,900 (75.2)			
		13½ (343)	20¼ (514)	54 (1372)	—	—	21,385 (95.1)			
		16⅞ (429)	25⅞ (645)	67½ (1715)	103,460 (460.2)	—	25,865 (115.1)			
1¼ (31.8)	1⅞	5⅞ (143)	8⅞ (214)	22½ (572)	32,368 (144.0)	2,054 (9.1)	8,090 (36.0)	23,490 (104.5)	50,620 (225.2)	34,420 (153.1)
		8⅞ (214)	12¼ (324)	33¼ (857)	—	—	13,090 (58.2)			
		11¼ (286)	16⅞ (429)	19¼ (502)	72,363 (321.9)	7,457 (33.2)	18,090 (80.5)			
		15 (381)	22½ (572)	60 (1524)	—	—	24,860 (110.6)			
		18¾ (476)	28⅞ (714)	75 (1905)	126,500 (562.7)	15,813 (70.3)	31,625 (140.7)			

- Reference page 318 for oversize holes.
- Allowable load must be the lesser of the bond or steel strength.
- The allowable loads listed under allowable bond are based on a safety factor of 4.0.
- Refer to allowable load-adjustment factors for spacing and edge distance on pages 97, 99 and 100.
- Refer to in-service temperature sensitivity chart for allowable load adjustment for temperature.
- Anchors are permitted to be used within fire-resistive construction, provided the anchors resist wind or seismic loads only. For use in fire-resistive construction, the anchors can also be permitted to be used to resist gravity loads, provided special consideration has been given to fire-exposure conditions.
- Anchors are not permitted to resist tension forces in overhead or wall installations unless proper consideration is given to fire-exposure and elevated-temperature conditions.

* See page 12 for an explanation of the load table icons.

AT Design Information — Concrete

AT Allowable Shear Loads for Threaded Rod Anchors
in Normal-Weight Concrete

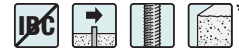

Adhesive Anchors

Rod Dia. in. (mm)	Drill Bit Dia. in.	Embed. Depth in. (mm)	Critical Edge Dist. in. (mm)	Critical Spacing Dist. in. (mm)	Shear Load Based on Concrete Edge Distance			Shear Load Based on Steel Strength		
					f' _c ≥ 2,000 psi (13.8 MPa) Concrete			F1554 Grade 36	A193 GR B7	F593 304SS
					Ultimate lb. (kN)	Std. Dev. lb. (kN)	Allowable lb. (kN)	Allowable lb. (kN)	Allowable lb. (kN)	Allowable lb. (kN)
3/8 (9.5)	7/16	1 3/4 (44)	5 1/4 (133)	2 5/8 (67)	4,869 (21.7)	369 (1.6)	1,215 (5.4)	1,085 (4.8)	2,340 (10.4)	1,870 (8.3)
		3 1/2 (89)		5 1/4 (133)	5,540 (24.6)	620 (2.8)	1,385 (6.2)			
		4 1/2 (114)		5 1/4 (133)	—	—	1,385 (6.2)			
1/2 (12.7)	9/16	2 1/8 (54)	6 3/8 (162)	3 1/4 (83)	8,318 (37.0)	643 (2.9)	2,080 (9.3)	1,930 (8.6)	4,160 (18.5)	3,330 (14.8)
		4 1/4 (108)		6 3/8 (162)	9,998 (44.5)	522 (2.3)	2,500 (11.1)			
		6 (152)		6 3/8 (162)	—	—	2,500 (11.1)			
5/8 (15.9)	1 1/16	2 1/2 (64)	7 1/2 (191)	3 3/4 (95)	14,806 (65.9)	728 (3.2)	3,700 (16.5)	3,025 (13.5)	6,520 (29.0)	5,220 (23.2)
		5 1/2 (140)		8 1/4 (210)	15,692 (69.8)	305 (1.4)	3,925 (17.5)			
		9 3/8 (238)		8 1/4 (210)	—	—	3,925 (17.5)			
3/4 (19.1)	1 3/16	3 3/8 (86)	10 1/8 (257)	5 1/8 (130)	20,350 (90.5)	—	5,090 (22.6)	4,360 (19.4)	9,390 (41.8)	6,385 (28.4)
		6 3/4 (171)		10 1/8 (257)	20,350 (90.5)	1,521 (6.8)	5,090 (22.6)			
		11 1/4 (286)		10 1/8 (257)	—	—	5,090 (22.6)			
7/8 (22.2)	1	3 7/8 (98)	11 5/8 (295)	5 7/8 (149)	27,475 (122.2)	1,655 (7.4)	6,870 (30.6)	5,925 (26.4)	12,770 (56.8)	8,685 (38.6)
		7 3/4 (197)		11 5/8 (295)	30,876 (137.3)	1,714 (7.6)	7,720 (34.3)			
		13 1/8 (333)		11 5/8 (295)	—	—	7,720 (34.3)			
1 (25.4)	1 1/16	4 1/2 (114)	13 1/2 (343)	6 3/4 (171)	32,687 (145.4)	2,287 (10.2)	8,170 (36.3)	7,740 (34.4)	16,680 (74.2)	11,345 (50.5)
		9 (229)		13 1/2 (343)	33,858 (150.6)	2,035 (9.1)	8,465 (37.7)			
		15 (381)		13 1/2 (343)	—	—	8,465 (37.7)			
1 1/8 (28.6)	1 3/16	5 1/8 (130)	15 1/4 (387)	7 3/4 (197)	41,536 (184.8)	—	10,385 (46.2)	9,800 (43.6)	21,125 (94.0)	14,365 (63.9)
		10 1/8 (257)		15 1/4 (387)	49,812 (221.6)	—	12,455 (55.4)			
		16 7/8 (429)		15 1/4 (387)	—	—	12,455 (55.4)			
1 1/4 (31.8)	1 5/16	5 5/8 (143)	16 7/8 (429)	8 1/2 (216)	50,385 (224.1)	1,090 (4.8)	12,595 (56.0)	12,100 (53.8)	26,075 (116.0)	17,730 (78.9)
		11 1/4 (286)		16 7/8 (429)	65,765 (292.5)	4,636 (20.6)	16,440 (73.1)			
		18 3/4 (476)		16 7/8 (429)	—	—	16,440 (73.1)			

1. Allowable load must be the lesser of the load based on concrete edge distance or steel strength.
2. The allowable loads based on concrete edge distance are based on a safety factor of 4.0.
3. Refer to allowable load-adjustment factors for spacing and edge distance on pages 98 and 100.
4. Refer to in-service temperature sensitivity chart for allowable load adjustment for temperature.
5. Anchors are permitted to be used within fire-resistive construction, provided the anchors resist wind or seismic loads only. For use in fire-resistive construction, the anchors can also be permitted to be used to resist gravity loads, provided special consideration has been given to fire-exposure conditions.

* See page 12 for an explanation of the load table icons.

AT Design Information — Concrete



AT Allowable Tension Loads for Rebar Dowels in Normal-Weight Concrete

Rebar Size No. (mm)	Drill Bit Dia. in.	Embed. Depth in. (mm)	Critical Edge Dist. in. (mm)	Critical Spacing Dist. in. (mm)	Tension Load Based on Bond Strength						Tension Load Based on Steel Strength
					f _c ≥ 2,000 psi (13.8 MPa) Concrete			f _c ≥ 4,000 psi (27.6 MPa) Concrete			ASTM A615 Grade 60 Rebar
					Ultimate lb. (kN)	Std. Dev. lb. (kN)	Allowable lb. (kN)	Ultimate lb. (kN)	Std. Dev. lb. (kN)	Allowable lb. (kN)	Allowable lb. (kN)
#3 (9.5)	½	3½ (89)	5¼ (133)	6⅞ (156)	8,245 (36.7)	849 (3.8)	2,060 (9.2)	—	—	2,060 (9.2)	2,640 (11.7)
		4½ (114)	5¼ (133)	6⅞ (156)	—	—	2,060 (9.2)	—	—	2,060 (9.2)	
#4 (12.7)	¾	4¼ (108)	6⅞ (162)	7½ (191)	12,743 (56.7)	1,760 (7.8)	3,185 (14.2)	—	—	3,185 (14.2)	4,800 (21.4)
		5⅞ (149)	8⅞ (225)	23½ (597)	—	—	3,185 (14.2)	—	—	3,985 (17.7)	
		7½ (191)	11¼ (286)	30 (762)	—	—	3,185 (14.2)	19,124 (85.1)	854 (3.8)	4,780 (21.3)	
#5 (15.9)	¾	5½ (140)	7½ (191)	9⅞ (244)	20,396 (90.7)	1,412 (6.3)	5,100 (22.7)	—	—	5,100 (22.7)	7,440 (33.1)
		7¼ (184)	10⅞ (276)	29 (737)	—	—	5,100 (22.7)	—	—	6,095 (27.1)	
		9⅞ (191)	14⅞ (359)	37½ (953)	—	—	5,100 (22.7)	28,115 (125.1)	1,496 (6.7)	7,030 (31.3)	
#6 (19.1)	7/8	6¼ (171)	10⅞ (257)	11⅞ (302)	31,839 (141.6)	1,454 (6.5)	7,960 (35.4)	—	—	7,960 (35.4)	10,560 (47.0)
		9 (229)	13½ (343)	36 (914)	—	—	7,960 (35.4)	—	—	8,730 (38.8)	
		11¼ (286)	16⅞ (429)	45 (1143)	—	—	7,960 (35.4)	37,992 (169.0)	1,999 (8.9)	9,500 (42.3)	
#7 (22.2)	1	7¾ (197)	11⅞ (295)	13⅞ (346)	35,250 (156.8)	2,693 (12.0)	8,815 (39.2)	—	—	8,815 (39.2)	14,400 (64.1)
		10½ (267)	15¾ (400)	42 (1067)	—	—	8,815 (39.2)	—	—	10,815 (48.1)	
		13⅞ (333)	19⅞ (498)	52½ (1334)	—	—	8,815 (39.2)	50,889 (226.4)	3,717 (16.5)	12,720 (56.6)	
#8 (25.4)	1 1/8	9 (229)	13½ (343)	15¾ (400)	49,973 (222.3)	5,023 (22.3)	12,495 (55.6)	—	—	12,495 (55.6)	18,960 (84.3)
		12 (305)	18 (457)	48 (1219)	—	—	12,495 (55.6)	—	—	16,325 (72.6)	
		15 (381)	22½ (572)	60 (1524)	—	—	12,495 (55.6)	80,598 (358.5)	2,195 (9.8)	20,150 (89.6)	
#9 (28.6)	1 1/4	16⅞ (429)	25⅞ (645)	67½ (1715)	—	—	—	96,096 (427.5)	489 (2.2)	24,025 (106.9)	24,000 (106.8)
#10 (31.8)	1 3/8	18¾ (476)	28⅞ (714)	75 (1905)	—	—	—	124,031 (551.7)	2,447 (10.9)	31,010 (137.9)	30,480 (135.6)
#11 (34.9)	1 5/8	20⅞ (524)	31 (787)	82½ (2096)	—	—	—	166,059 (738.7)	4,222 (18.8)	41,515 (184.7)	37,440 (166.5)

1. Allowable load must be the lesser of the bond or steel strength.
2. The allowable loads listed under allowable bond are based on a safety factor of 4.0.
3. Refer to allowable load-adjustment factors for spacing and edge distance on pages 97, 99 and 100.
4. Refer to in-service temperature sensitivity chart for allowable load adjustment for temperature.
5. Anchors are permitted to be used within fire-resistive construction, provided the anchors resist wind or seismic loads only. For use in fire-resistive construction, the anchors can also be permitted to be used to resist gravity loads, provided special consideration has been given to fire-exposure conditions.
6. Anchors are not permitted to resist tension forces in overhead or wall installations unless proper consideration is given to fire-exposure and elevated-temperature conditions.

* See page 12 for an explanation of the load table icons.

AT Design Information — Concrete

AT Allowable Shear Loads for Rebar Dowels in Normal-Weight Concrete

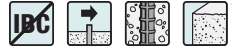

Rebar Size No. (mm)	Drill Bit Dia. in.	Embed. Depth in. (mm)	Critical Edge Dist. in. (mm)	Critical Spacing Dist. in. (mm)	Shear Load Based on Concrete Edge Distance			Shear Load Based on Steel Strength
					$f'_c \geq 2,000$ psi (13.8 MPa) Concrete			ASTM A615 Grade 60 Rebar
					Ultimate lb. (kN)	Std. Dev. lb. (kN)	Allowable lb. (kN)	Allowable lb. (kN)
#3 (9.5)	1/2	3 1/2 (89)	6 (152)	5 1/4 (133)	8,294 (36.9)	515 (2.3)	2,075 (9.2)	1,680 (7.5)
		4 1/2 (114)			—	—	2,075 (9.2)	
#4 (12.7)	9/16	4 1/4 (108)	8 (203)	6 3/8 (162)	11,012 (49.0)	383 (1.7)	2,755 (12.3)	3,060 (13.6)
		7 1/2 (191)			—	—	2,755 (12.3)	
#5 (15.9)	3/4	5 1/2 (140)	10 (254)	8 1/4 (210)	15,758 (70.1)	1,154 (5.1)	3,940 (17.5)	4,740 (21.1)
		9 3/8 (238)			—	—	3,940 (17.5)	
#6 (19.1)	7/8	6 3/4 (171)	12 (305)	10 1/8 (257)	23,314 (103.7)	1,494 (6.6)	5,830 (25.9)	6,730 (29.9)
		11 1/4 (286)			—	—	5,830 (25.9)	
#7 (22.2)	1	7 3/4 (197)	14 (356)	11 5/8 (295)	32,662 (145.3)	5,588 (24.9)	8,165 (36.3)	9,180 (40.8)
		13 1/8 (333)			—	—	8,165 (36.3)	
#8 (25.4)	1 1/8	9 (229)	16 (406)	13 1/2 (343)	33,428 (148.7)	2,319 (10.3)	8,360 (37.2)	12,085 (53.8)
		15 (381)			—	—	8,360 (37.2)	

1. Allowable load must be the lesser of the load based on concrete edge distance or steel strength.
2. The allowable loads based on concrete edge distance are based on a safety factor of 4.0.
3. Refer to allowable load-adjustment factors for spacing and edge distance on pages 98 and 100.
4. Refer to in-service temperature sensitivity chart for allowable load adjustment for temperature.
5. Anchors are permitted to be used within fire-resistive construction, provided the anchors resist wind or seismic loads only. For use in fire-resistive construction, the anchors can also be permitted to be used to resist gravity loads, provided special consideration has been given to fire-exposure conditions.

AT Allowable Tension Loads for Threaded Rod Anchors in Normal-Weight Concrete Stemwall



Rod Dia. in. (mm)	Drill Bit Dia. in.	Embed. Depth in. (mm)	Stemwall Width in. (mm)	Min. Edge Dist. in. (mm)	Min. End Dist. in. (mm)	Tension Load Based on Bond Strength		Tension Load Based on Steel Strength
						$f'_c \geq 2,500$ psi (17.2 MPa) Concrete		F1554 Grade 36
						Ultimate lb. (kN)	Allowable lbs. (kN)	Allowable lbs. (kN)
5/8 (15.9)	1 1/16	10 (254.0)	6 (152.4)	1 3/4 (44.5)	5 (127.0)	12,913 (57.4)	3,230 (14.4)	5,875 (26.1)
7/8 (22.2)	1	15 (381.0)	8 (203.2)	1 3/4 (44.5)	5 (127.0)	21,838 (97.1)	5,460 (24.3)	11,500 (51.2)

1. Allowable load must be the lesser of the bond or steel strength.
2. The allowable loads listed under allowable bond are based on a safety factor of 4.0.
3. Refer to in-service temperature sensitivity chart for allowable load adjustment for temperature.
4. Anchors are permitted to be used within fire-resistive construction, provided the anchors resist wind or seismic loads only. For use in fire-resistive construction, the anchors can also be permitted to be used to resist gravity loads, provided special consideration has been given to fire-exposure conditions.

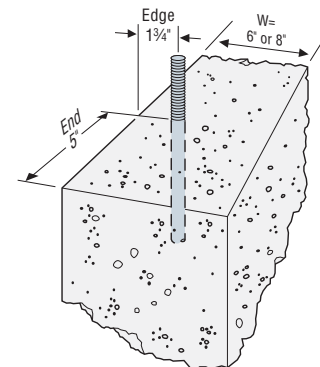

Edge and end distances for threaded rod in concrete foundation stemwall corner installation

* See page 12 for an explanation of the load table icons.

AT Design Information — Concrete

AT Allowable Tension Loads for Threaded Rod Anchors in Sand-Lightweight Concrete



Rod Dia. in. (mm)	Drill Bit Dia. in.	Embed. Depth in. (mm)	Critical Edge Dist. in. (mm)	Critical Spacing Dist. in. (mm)	Tension Load Based on Bond Strength			Tension Load Based on Steel Strength		
					$f'_c \geq 3,000$ psi (20.7 MPa) Lightweight Concrete			F1554 Grade 36	A193 GR B7	F593 304SS
					Ultimate lb. (kN)	Std. Dev. lb. (kN)	Allowable lb. (kN)	Allowable lb. (kN)	Allowable lb. (kN)	Allowable lb. (kN)
3/8 (9.5)	7/16	1 3/4 (44)	2 5/8 (67)	3 1/2 (89)	2,842 (12.6)	226 (1.0)	710 (3.2)	2,105 (9.4)	4,535 (20.2)	3,630 (16.1)
		3 1/2 (89)	5 1/4 (133)	7 (178)	5,132 (22.8)	762 (3.4)	1,280 (5.7)			
1/2 (12.7)	9/16	2 1/8 (54)	3 1/8 (79)	4 1/4 (108)	4,415 (19.6)	454 (2.0)	1,100 (4.9)	3,750 (16.7)	8,080 (35.9)	6,470 (28.8)
		4 1/4 (108)	6 3/8 (162)	8 1/2 (216)	6,709 (29.8)	1,002 (4.5)	1,675 (7.5)			
5/8 (15.9)	1 1/16	2 1/2 (64)	3 3/4 (95)	5 (127)	5,568 (24.8)	498 (2.2)	1,390 (6.2)	5,875 (26.1)	12,660 (56.3)	10,120 (45.0)
		5 (127)	7 1/2 (191)	10 (254)	6,298 (28.0)	1,155 (5.1)	1,575 (7.0)			

1. Allowable load must be the lesser of the bond or steel strength.
2. 100% of the allowable load is permitted at critical spacing. No reduction in spacing is allowed.
3. Refer to allowable load-adjustment factors for edge distance on page 101.
4. Refer to in-service temperature sensitivity chart for allowable load adjustment for temperature.
5. Anchors are permitted to be used within fire-resistive construction, provided the anchors resist wind or seismic loads only. For use in fire-resistive construction, the anchors can also be permitted to be used to resist gravity loads, provided special consideration has been given to fire-exposure conditions.
6. Anchors are not permitted to resist tension forces in overhead or wall installations unless proper consideration is given to fire-exposure and elevated-temperature conditions.
7. The allowable loads listed under allowable bond are based on a safety factor of 4.0.

AT Allowable Shear Loads for Threaded Rod Anchors in Sand-Lightweight Concrete



Rod Dia. in. (mm)	Drill Bit Dia. in.	Embed. Depth in. (mm)	Critical Edge Dist. in. (mm)	Critical Spacing Dist. in. (mm)	Shear Load Based on Concrete Edge Distance			Shear Load Based on Steel Strength		
					$f'_c \geq 3,000$ psi (20.7 MPa) Lightweight Concrete			F1554 Grade 36	A193 GR B7	F593 304SS
					Ultimate lb. (kN)	Std. Dev. lb. (kN)	Allowable lb. (kN)	Allowable lb. (kN)	Allowable lb. (kN)	Allowable lb. (kN)
3/8 (9.5)	7/16	1 3/4 (44)	2 5/8 (67)	3 1/2 (89)	3,042 (13.5)	249 (1.1)	760 (3.4)	1,085 (4.8)	2,340 (10.4)	1,870 (8.3)
		3 1/2 (89)	5 1/4 (133)	7 (178)	5,320 (23.7)	187 (0.8)	1,330 (5.9)			
1/2 (12.7)	9/16	2 1/8 (54)	3 1/8 (79)	4 1/4 (108)	4,076 (18.1)	458 (2.0)	1,020 (4.5)	1,930 (8.6)	4,160 (18.5)	3,330 (14.8)
		4 1/4 (108)	6 3/8 (162)	8 1/2 (216)	9,838 (43.8)	625 (2.8)	2,460 (10.9)			
5/8 (15.9)	1 1/16	2 1/2 (64)	3 3/4 (95)	5 (127)	5,360 (23.8)	351 (1.6)	1,340 (6.0)	3,025 (13.5)	6,520 (29.0)	5,220 (23.2)
		5 (127)	7 1/2 (191)	10 (254)	12,430 (55.3)	518 (2.3)	3,105 (13.8)			

1. Allowable load must be the lesser of the load based on concrete edge distance or steel strength.
2. The allowable loads based on concrete edge distance are based on a safety factor of 4.0.
3. Refer to allowable load-adjustment factors for edge distance on page 101.
4. Refer to in-service temperature sensitivity chart for allowable load adjustment for temperature.
5. Anchors are permitted to be used within fire-resistive construction, provided the anchors resist wind or seismic loads only. For use in fire-resistive construction, the anchors can also be permitted to be used to resist gravity loads, provided special consideration has been given to fire-exposure conditions.
6. 100% of the allowable load is permitted at critical spacing. No reduction in spacing is allowed.

* See page 12 for an explanation of the load table icons.

AT Design Information — Masonry

AT Allowable Tension and Shear Loads for Threaded Rod Anchors in 6- and 8-Inch Normal-Weight Grout-Filled CMU



Rod Dia. in. (mm)	Drill Bit Dia. in.	Embed. Depth in. (mm)	Min. Edge Dist. in. (mm)	Min. End Dist. in. (mm)	Min. Spacing Dist. in. (mm)	6-Inch Grout-Filled CMU Allowable Loads Based on CMU Strength		8-Inch Grout-Filled CMU Allowable Loads Based on CMU Strength	
						Tension	Shear	Tension	Shear
						Allowable lb. (kN)	Allowable lb. (kN)	Allowable lb. (kN)	Allowable lb. (kN)
Anchor Installed in Face Shell (See Figure 1)									
1/2 (12.7)	9/16	4 1/4 (108)	12 (305)	12 (305)	17 (432)	770 (3.4)	1,325 (5.9)	770 (3.4)	1,325 (5.9)
3/4 (19.1)	1 3/16	6 3/4 (171)	12 (305)	4 (102)	27 (686)	—	—	1,375 (6.1)	—
				12 (305)	27 (686)	—	—	—	2,670 (11.9)
Anchor Installed in Mortar "T" Joint (See Figure 2)									
3/4 (19.1)	1 3/16	6 3/4 (171)	16 (406)	8 (203)	27 (686)	—	—	—	1,030 (4.6)

See notes 1-7 below

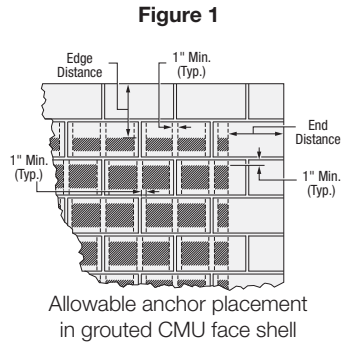

AT Allowable Tension and Shear Loads for Threaded Rod Anchors in 6- and 8-Inch Normal-Weight Grout-Filled CMU



Rod Dia. in. (mm)	Drill Bit Dia. in.	Embed. Depth in. (mm)	Min. Edge Dist. in. (mm)	Min. End Dist. in. (mm)	Min. Spacing Dist. in. (mm)	6- and 8-Inch Grout-Filled CMU Allowable Loads Based on CMU Strength		
						Tension	Shear Perpendicular ⁸	Shear Parallel ⁹
						Allowable lb. (kN)	Allowable lb. (kN)	Allowable lb. (kN)
Anchor Installed in Cell Opening (Top-of-Wall) (See Figure 3)								
1/2 (12.7)	9/16	4 1/4 (108)	1 3/4 (44)	11 (279)	17 (432)	650 (2.9)	285 (1.3)	705 (3.1)
5/8 (15.9)	1 1/16	5 (127)	1 3/4 (44)	11 (279)	20 (508)	815 (3.6)	330 (1.5)	755 (3.4)
		12 (305)	1 3/4 (44)	11 (279)	48 (1219)	1,120 (5.0)	410 (1.8)	815 (3.6)
7/8 (22.2)	1	12 (305)	1 3/4 (44)	11 (279)	48 (1219)	1,385 (6.2)	290 (1.3)	1,030 (4.6)

- Threaded rods must comply with ASTM F1554 Grade 36 minimum.
- Values for 6- and 8-inch wide concrete masonry units (CMU) with a minimum specified compressive strength of masonry, f'_m , at 28 days is 1500 psi.
- Embedment depth is measured from the outside face of the concrete masonry unit for installations through a face shell.
- Allowable loads may be increased 33 1/3% for short-term loading due to wind or seismic forces where permitted by code.
- Refer to in-service temperature sensitivity chart for allowable load adjustment for temperature.
- The tabulated allowable loads are based on a safety factor of 5.0.
- Anchors must be spaced a minimum distance of four times the anchor embedment.
- Shear load applied perpendicular to edge of CMU wall.
- Shear load applied parallel to edge of CMU wall.

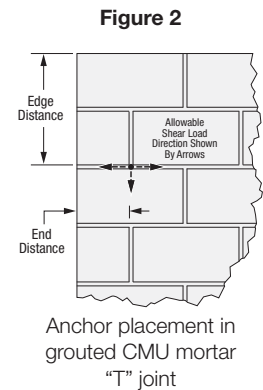

AT Allowable Tension and Shear Loads for Threaded Rod Anchors in Lightweight, Medium-Weight and Normal-Weight Hollow CMU







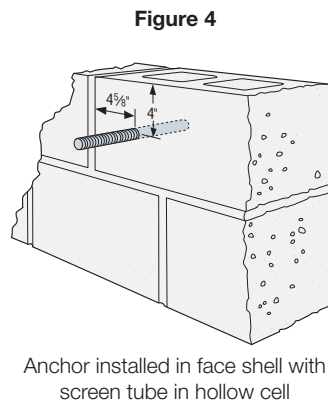
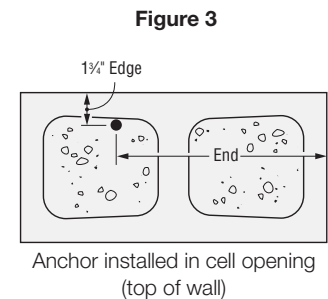

Rod Dia. in. (mm)	Drill Bit Dia. in.	Embed. Depth in. (mm)	Min. Edge Dist. in. (mm)	Min. End Dist. in. (mm)	6- and 8-Inch Hollow CMU Allowable Loads Based on CMU Strength			
					Tension		Shear	
					Ultimate lb. (kN)	Allowable lb. (kN)	Ultimate lb. (kN)	Allowable lb. (kN)
Anchor Installed in Face Shell with Simpson Strong-Tie® Stainless-Steel Screen Tube (See Figure 4)								
3/8 (9.5)	9/16	3 1/2 (88.9)	4 (101.6)	4 5/8 (117.5)	1,400 (6.2)	280 (1.2)	1,326 (5.9)	265 (1.2)
1/2 (12.7)	1 1/16	3 1/2 (88.9)	4 (101.6)	4 5/8 (117.5)	—	280 (1.2)	—	265 (1.2)
5/8 (15.9)	7/8	3 (76.2)	4 (101.6)	4 5/8 (117.5)	—	280 (1.2)	—	265 (1.2)

- See notes 1, 2, 3, 5, 6, 7 above.
- Set drill to rotation-only mode when drilling into hollow CMU.

* See page 12 for an explanation of the load table icons.



AT Design Information — Masonry

AT Allowable Tension and Shear Loads for Installations in Unreinforced Brick Masonry Walls— Minimum URM Wall Thickness is 13" (3 wythes thick)       *

Rod/Rebar Dia./Size in. (mm)	Drill Bit Dia. in.	Embed. Depth in. (mm)	Min. Edge/End Dist. in. (mm)	Min. Vertical Spacing Dist. in. (mm)	Min. Horiz. Spacing Dist. in. (mm)	Tension Load Based on URM Strength		Shear Load Based on URM Strength	
						Minimum Net Mortar Strength = 50 psi		Minimum Net Mortar Strength = 50 psi	
						Allowable lb. (kN)	Allowable lb. (kN)	Allowable lb. (kN)	Allowable lb. (kN)
Configuration A (Simpson Strong-Tie® ATS or ATSP Screen Tube Required)									
3/4 (19.1)	1	8 (203)	24 (610)	18 (457)	18 (457)	—	—	1,000 (4.4)	—
#5 (15.9)	1	8 (203)	24 (610)	18 (457)	18 (457)	—	—	750 (3.3)	—
#6 (19.1)	1	8 (203)	24 (610)	18 (457)	18 (457)	—	—	1,000 (4.4)	—
Configuration B (Simpson Strong-Tie ATS or ATSP Screen Tube Required)									
3/4 (19.1)	1	13 (330)	16 (406)	18 (457)	24 (610)	1,200 (5.3)	—	1,000 (4.4)	—
Configuration C (Simpson Strong-Tie ATS Screen Tube and AST Steel Sleeve Required)									
5/8 (15.9)	1	**	24 (610)	18 (457)	18 (457)	1,200 (5.3)	—	750 (3.3)	—

1. Threaded rods must comply with ASTM F1554 Grade 36 minimum.
2. All holes are drilled with a 1" diameter carbide-tipped drill bit with the drill set in the rotation-only mode.
3. The unreinforced brick walls must have a minimum thickness of 13 inches (three wythes of brick).
4. The allowable load is applicable only where in-place shear tests indicate minimum net mortar strength of 50 psi.
5. The allowable load for Configuration B and C anchors subjected to a combined tension and shear load is determined by assuming a straight-line relationship between allowable tension and shear.
6. The anchors installed in unreinforced brick walls are limited to resisting seismic or wind forces only.
7. Configuration A has a straight threaded rod or rebar embedded 8 inches into the wall with a 3/4" diameter by 8-inch long screen tube (part # ATS758 or ATS758P). This configuration is designed to resist shear loads only.
8. Configuration B has a 3/4" threaded rod bent and installed at a 22.5-degree angle and installed 13 inches into the wall, to within 1-inch (maximum) of the exterior wall surface. This configuration is designed to resist tension and shear loads. The pre-bent threaded rod is installed with a 3/4" diameter by 13-inch long screen tube (part # ATS7513 or ATS7513P).
9. Configuration C is designed to resist tension and shear forces. It consists of a 5/8" diameter, ASTM F1554 Grade 36 threaded rod and an 8" long steel sleeve (part # AST800) and a 3/4" diameter by 8-inch long screen tube (part # ATS758). The steel sleeve has a plastic plug in one end. A 6" by 6" by 5/8" thick ASTM A 36 steel plate is located on the back face of the wall.
10. Special inspection requirements are determined by local jurisdiction and must be confirmed by the local building official.
11. Refer to in-service temperature sensitivity chart for allowable load adjustment for temperature.

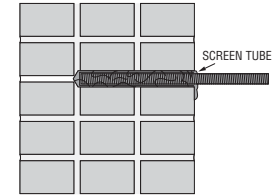

Configuration A (Shear)

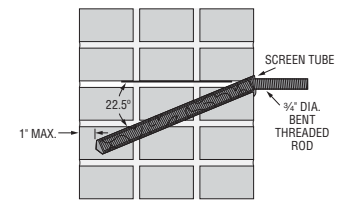

Configuration B (Tension & Shear)

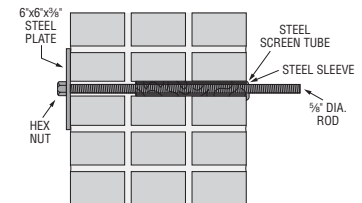

Configuration C (Tension & Shear)

AT Allowable Tension and Shear Loads for Threaded Rod Anchors in Lightweight, Medium-Weight and Normal-Weight Hollow CMU      *

Rod Dia. in. (mm)	Drill Bit Dia. in.	Embed. Depth in. (mm)	Critical Edge Dist. in. (mm)	Critical Spacing Dist. in. (mm)	8-inch Hollow CMU Allowable Loads Based on CMU Strength			
					Tension		Shear	
					Ultimate lb. (kN)	Allowable lb. (kN)	Ultimate lb. (kN)	Allowable lb. (kN)
Anchor Installed in Face Shell with Simpson Strong-Tie ATSP (Plastic) Screen Tube								
5/8 (15.9)	9/16	3 1/2 (88.9)	12 (305)	8 (203)	1,545 (6.9)	310 (1.4)	1,385 (6.2)	275 (1.2)
1/2 (12.7)	3/4	3 1/2 (88.9)	12 (305)	8 (203)	1,510 (6.7)	300 (1.3)	1,305 (5.8)	260 (1.2)
5/8 (15.9)	7/8	3 (76.2)	12 (305)	8 (203)	1,590 (7.1)	320 (1.4)	1,345 (6.0)	270 (1.2)

1. Threaded rods must comply with ASTM F1554 Grade 36 minimum.
2. The tabulated allowable loads are based on a safety factor of 5.0 for installations under the IBC and IRC.
3. Edge distances may be reduced to 4" with a corresponding 37% reduction in tension capacity. Shear capacity is unaffected.
4. Values for 8-inch wide, lightweight, medium-weight and normal-weight concrete masonry units with min. compressive strength of 1,900 psi and 1 1/4" thick face shell.
5. Embedment depth is measured from the outside face of the concrete masonry unit.
6. Refer to in-service temperature sensitivity chart for allowable load adjustment for temperature.
7. Set drill to rotation-only mode when drilling into hollow CMU.

* See page 12 for an explanation of the load table icons.

Installation Instructions for Configuration C

1. Drill hole perpendicular to the wall to a depth of 8" with a 1" diameter carbide-tipped drill bit (rotation only mode).
2. Clean hole with oil-free compressed air and a nylon brush.
3. Fill 8" steel screen tube with mixed adhesive and insert into hole.
4. Insert steel sleeve slowly into screen tube (adhesive will displace).
5. Allow adhesive to cure (see cure schedule).
6. Drill through plastic plug in (inside) end of steel sleeve with 5/8" bit.
7. Drill completely through the wall with 5/8" carbide tipped concrete drill bit (rotation mode only).
8. Insert 5/8" rod through hole and attach metal plate and nut.

AT Design Information — Masonry

AT Allowable Tension Loads for Threaded Rod Anchors in 8-inch Lightweight, Medium-Weight and Normal-Weight CMU Chair Blocks Filled with Normal-Weight Concrete

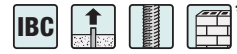

Adhesive Anchors

Rod Dia. in. (mm)	Drill Bit Dia. in.	Min. Embed. Depth in. (mm)	Min. Edge Dist. in. (mm)	Critical Spacing Dist. in. (mm)	8-inch Concrete-Filled CMU Chair Block	
					Allowable Tension Loads Based on CMU Strength	
					Ultimate lb. (kN)	Allowable lb. (kN)
1/2 (12.7)	9/16	4 1/2 (114)	1 3/4 (44.5)	18 (457)	3,540 (15.7)	710 (3.2)
		7 (178)	1 3/4 (44.5)	28 (711)	6,285 (28.0)	1,255 (5.6)
		12 (305)	1 3/4 (44.5)	48 (1,220)	18,950 (84.3)	3,750 (16.7)
5/8 (15.9)	1 1/16	4 1/2 (114)	1 3/4 (44.5)	18 (457)	4,775 (21.2)	955 (4.2)
		7 (178)	1 3/4 (44.5)	28 (711)	7,960 (35.4)	1,590 (7.1)
		12 (305)	1 3/4 (44.5)	48 (1,219)	—	3,400 (15.1)
		15 (381)	1 3/4 (44.5)	60 (1,524)	22,425 (99.8)	4,485 (20.0)

1. Threaded rods must comply with ASTM F1554 Grade 36 minimum.
2. Values are for 8-inch wide concrete masonry units CMU filled with concrete with minimum compressive strength of 2,500 psi and poured monolithically with the floor slab.
3. Center #5 rebar in CMU cell and concrete slab as shown.
4. The tabulated allowable loads are based on a safety factor of 5.0.

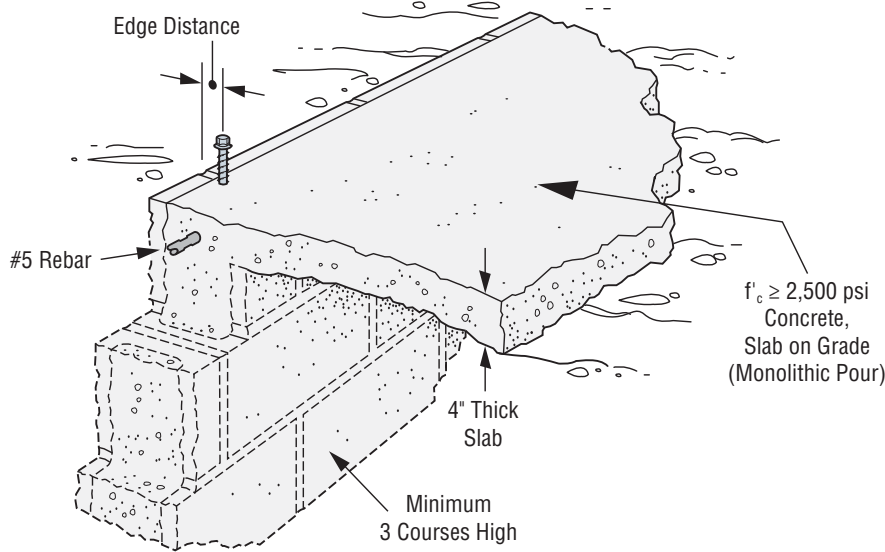

* See page 12 for an explanation of the load table icons.

AT Design Information — Concrete

AT Allowable Load Adjustment Factors in Normal-Weight Concrete: Edge Distance, Tension Load

How to use these charts

1. The following tables are for reduced edge distance.
2. Locate the anchor size to be used for either a tension and/or shear load application.
3. Locate the embedment (E) at which the anchor is to be installed.
4. Locate the edge distance (C_{act}) at which the anchor is to be installed.
5. The load-adjustment factor (f_c) is the intersection of the row and column.
6. Multiply the allowable load by the applicable load-adjustment factor.
7. Reduction factors for multiple edges are multiplied together.
8. Adjustment factors do not apply to allowable steel strength values.
9. Adjustment factors are to be applied to allowable tension load based on bond strength values only.

Edge Distance Tension (f_c)

Edge Dist. C_{act} (in.)	Dia.	3/8			1/2			5/8			3/4			
	Rebar	#3			#4			#5			#6			
	E	1 3/4	3 1/2	4 1/2	2 1/8	4 1/4	6	7 1/2	2 1/2	5 1/2	9 3/8	3 3/8	6 3/4	11 1/4
	C_{cr}	2 5/8	5 1/4	6 3/4	3 3/16	6 3/8	9	11 1/4	3 3/4	7 1/2	14 1/8	5 1/16	10 1/8	16 7/8
C_{min}	1 3/4	1 3/4	1 3/4	1 3/4	1 3/4	1 3/4	1 3/4	1 3/4	1 3/4	1 3/4	1 3/4	1 3/4	1 3/4	
f_{cmin}	0.59	0.59	0.65	0.50	0.50	0.65	0.65	0.50	0.50	0.61	0.50	0.50	0.56	
1 3/4		0.59	0.59	0.65	0.50	0.50	0.65	0.65	0.50	0.50	0.61	0.50	0.50	0.56
2		0.71	0.62	0.67	0.59	0.53	0.66	0.66	0.56	0.52	0.62	0.54	0.51	0.57
3		1.00	0.74	0.74	0.93	0.64	0.71	0.70	0.81	0.61	0.65	0.69	0.57	0.60
4			0.85	0.81	1.00	0.74	0.76	0.73	1.00	0.70	0.68	0.84	0.63	0.63
5			0.97	0.88		0.85	0.81	0.77		0.78	0.71	0.99	0.69	0.65
6			1.00	0.95		0.96	0.86	0.81		0.87	0.74	1.00	0.75	0.68
7				1.00		1.00	0.90	0.84		0.96	0.78		0.81	0.71
8							0.95	0.88		1.00	0.81		0.87	0.74
9							1.00	0.92			0.84		0.93	0.77
10								0.95			0.87		0.99	0.80
11								0.99			0.90		1.00	0.83
12								1.00			0.93			0.86
13											0.96			0.89
14											1.00			0.92
15														0.95
16														0.97
17														1.00

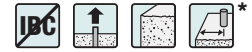

See notes below.

Edge Distance Tension (f_c) (continued)

Edge Dist. C_{act} (in.)	Dia.	7/8			1			1 1/8			1 1/4			
	Rebar	#7			#8			#9			#10		#11	
	E	3 7/8	7 3/4	13 1/8	4 1/2	9	15	5 5/8	10 1/8	16 7/8	5 5/8	11 1/4	18 3/4	20 5/8
	C_{cr}	5 13/16	11 5/8	19 5/8	6 3/4	13 1/2	22 1/2	7 3/4	15 1/4	25 3/8	8 7/16	16 7/8	28 1/8	31
C_{min}	1 3/4	1 3/4	1 3/4	1 3/4	1 3/4	1 3/4	2 3/4	2 3/4	2 3/4	2 3/4	2 3/4	2 3/4	2 3/4	
f_{cmin}	0.49	0.49	0.52	0.44	0.44	0.39	0.47	0.47	0.43	0.47	0.47	0.43	0.43	
1 3/4		0.49	0.49	0.52	0.44	0.44	0.39							
2 3/4		0.62	0.54	0.55	0.55	0.49	0.42	0.47	0.47	0.43	0.47	0.47	0.43	0.43
4		0.77	0.61	0.58	0.69	0.55	0.46	0.60	0.52	0.46	0.59	0.52	0.46	0.46
6		1.00	0.71	0.63	0.92	0.64	0.51	0.81	0.61	0.51	0.77	0.59	0.50	0.50
8			0.81	0.69	1.00	0.74	0.57	1.00	0.69	0.56	0.96	0.67	0.55	0.54
10			0.92	0.74		0.83	0.63		0.78	0.61	1.00	0.74	0.59	0.58
12			1.00	0.80		0.93	0.69		0.86	0.66		0.82	0.64	0.62
14				0.85		1.00	0.75		0.95	0.71		0.89	0.68	0.66
16				0.90			0.81		1.00	0.76		0.97	0.73	0.70
18				0.96			0.87			0.81		1.00	0.77	0.74
20				1.00			0.93			0.86			0.82	0.78
22							0.99			0.91			0.86	0.82
24							1.00			0.97			0.91	0.86
26										1.00			0.95	0.90
28													1.00	0.94
30														0.98
32														1.00

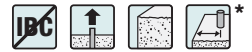

1. E = Embedment depth (inches).
2. C_{act} = actual edge distance at which anchor is installed (inches).
3. C_{cr} = critical edge distance for 100% load (inches).
4. C_{min} = minimum edge distance for reduced load (inches).
5. f_c = adjustment factor for allowable load at actual edge distance.
6. f_{ocr} = adjustment factor for allowable load at critical edge distance. f_{ocr} is always = 1.00.
7. f_{cmin} = adjustment factor for allowable load at minimum edge distance.
8. $f_c = f_{cmin} + [(1 - f_{cmin})(C_{act} - C_{min}) / (C_{cr} - C_{min})]$.

* See page 12 for an explanation of the load table icons.

AT Design Information — Concrete

AT Allowable Load Adjustment Factors in Normal-Weight Concrete: Edge Distance, Shear Load

How to use these charts

- The following tables are for reduced edge distance.
- Locate the anchor size to be used for either a tension and/or shear load application.
- Locate the embedment (E) at which the anchor is to be installed.
- Locate the edge distance (C_{act}) at which the anchor is to be installed.
- The load-adjustment factor (f_d) is the intersection of the row and column.
- Multiply the allowable load by the applicable load-adjustment factor.
- Reduction factors for multiple edges are multiplied together.
- Adjustment factors do not apply to allowable steel strength values.
- Adjustment factors are to be applied to allowable shear load based on concrete edge distance values only.

Edge Distance Shear (f_c)

Edge Dist. C_{act} (in.)	Di.	$\frac{3}{8}$					$\frac{1}{2}$					$\frac{5}{8}$					$\frac{3}{4}$					$\#6$				
	Rebar																									
	E	1¼	3½	4½	3½	4½	2½	4¼	6	4¼	7½	2½	5½	9½	5½	9½	3½	6¼	11¼	6¼	11¼	6¼	11¼			
	C_{cr}	5¼	5¼	5¼	6	6	6¾	6¾	6¾	8	8	7½	7½	7½	10	10	10¾	10¾	10¾	12	12	12	12			
	C_{min}	1¼	1¼	1¼	1¼	1¼	1¼	1¼	1¼	1¼	1¼	1¼	1¼	1¼	1¼	1¼	1¼	1¼	1¼	1¼	1¼	1¼	1¼			
	f_{cmin}	0.40	0.35	0.39	0.19	0.39	0.18	0.15	0.25	0.16	0.25	0.12	0.11	0.14	0.10	0.14	0.10	0.11	0.14	0.10	0.14	0.10	0.14			
1¼		0.40	0.35	0.39	0.19	0.39	0.18	0.15	0.25	0.16	0.25	0.12	0.11	0.14	0.10	0.14	0.10	0.11	0.14	0.10	0.14	0.10	0.14			
2¼		0.57	0.54	0.56	0.38	0.53	0.36	0.33	0.41	0.29	0.37	0.27	0.26	0.29	0.21	0.24	0.21	0.22	0.24	0.19	0.22	0.19	0.22			
3		0.61	0.58	0.61	0.43	0.57	0.40	0.38	0.45	0.33	0.40	0.31	0.30	0.33	0.24	0.27	0.23	0.24	0.27	0.21	0.24	0.21	0.24			
3½		0.70	0.68	0.70	0.52	0.64	0.49	0.47	0.53	0.40	0.46	0.39	0.38	0.40	0.29	0.32	0.29	0.30	0.32	0.25	0.29	0.25	0.29			
4		0.79	0.77	0.78	0.62	0.71	0.58	0.56	0.61	0.46	0.52	0.46	0.46	0.48	0.35	0.37	0.34	0.35	0.37	0.30	0.33	0.30	0.33			
4½		0.87	0.86	0.87	0.71	0.78	0.67	0.66	0.70	0.53	0.58	0.54	0.54	0.55	0.40	0.43	0.40	0.40	0.42	0.34	0.37	0.34	0.37			
5		0.96	0.95	0.96	0.81	0.86	0.76	0.75	0.78	0.60	0.64	0.62	0.61	0.63	0.45	0.48	0.45	0.46	0.47	0.39	0.41	0.39	0.41			
5½		1.00	1.00	1.00	0.90	0.93	0.84	0.84	0.86	0.66	0.70	0.69	0.69	0.70	0.51	0.53	0.50	0.51	0.53	0.43	0.45	0.43	0.45			
6					1.00	1.00	0.93	0.93	0.94	0.73	0.76	0.77	0.77	0.78	0.56	0.58	0.56	0.56	0.58	0.47	0.50	0.47	0.50			
6½							1.00	1.00	1.00	0.80	0.82	0.85	0.85	0.85	0.62	0.64	0.61	0.61	0.63	0.52	0.54	0.52	0.54			
7											0.87	0.88	0.92	0.92	0.93	0.67	0.69	0.66	0.67	0.68	0.56	0.58	0.56	0.58		
7½											0.93	0.94	1.00	1.00	1.00	0.73	0.74	0.72	0.72	0.73	0.60	0.62	0.60	0.62		
8											1.00	1.00					0.78	0.79	0.77	0.77	0.78	0.65	0.66	0.65	0.66	
8½																	0.84	0.84	0.83	0.83	0.83	0.69	0.71	0.69	0.71	
9																	0.89	0.90	0.88	0.88	0.88	0.74	0.75	0.74	0.75	
9½																	0.95	0.95	0.93	0.93	0.94	0.78	0.79	0.78	0.79	
10																	1.00	1.00	0.99	0.99	0.99	0.82	0.83	0.82	0.83	
10½																			1.00	1.00	1.00	0.87	0.87	0.87	0.87	
11																						0.91	0.92	0.91	0.92	
11½																						0.96	0.96	0.96	0.96	
12																						1.00	1.00	1.00	1.00	

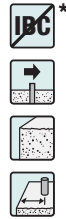

See notes below.

Edge Distance Shear (f_c) (continued)

Edge Dist. C_{act} (in.)	Di.	$\frac{7}{8}$					1					1½					1¾				
	Rebar																				
	E	3¾	7¼	13½	7¼	13½	4½	9	15	9	15	5½	10½	16¾	5½	11¼	18¾	5½	11¼	18¾	
	C_{cr}	11½	11½	11½	14	14	13½	13½	13½	16	16	15¼	15¼	15¼	16¾	16¾	16¾	16¾	16¾	16¾	
	C_{min}	1¼	1¼	1¼	1¼	1¼	1¼	1¼	1¼	1¼	1¼	2¼	2¼	2¼	2¼	2¼	2¼	2¼	2¼		
	f_{cmin}	0.09	0.08	0.09	0.09	0.09	0.08	0.08	0.09	0.08	0.09	0.14	0.12	0.12	0.14	0.12	0.12	0.14	0.12	0.12	
1¼		0.09	0.08	0.09	0.09	0.09	0.08	0.08	0.09	0.08	0.09										
2¼		0.18	0.17	0.18	0.16	0.16	0.16	0.16	0.17	0.14	0.15	0.14	0.12	0.12	0.14	0.12	0.12	0.14	0.12	0.12	
3		0.21	0.20	0.21	0.18	0.18	0.18	0.18	0.19	0.16	0.17	0.16	0.14	0.14	0.14	0.14	0.14	0.14	0.14	0.14	
4		0.30	0.29	0.30	0.26	0.26	0.26	0.26	0.26	0.23	0.23	0.23	0.21	0.21	0.22	0.20	0.20	0.20	0.20	0.20	
5		0.39	0.38	0.39	0.33	0.33	0.33	0.33	0.34	0.29	0.30	0.29	0.28	0.28	0.28	0.26	0.26	0.26	0.26	0.26	
6		0.48	0.48	0.48	0.41	0.41	0.41	0.41	0.42	0.35	0.36	0.36	0.35	0.35	0.34	0.32	0.32	0.32	0.32	0.32	
7		0.57	0.57	0.57	0.48	0.48	0.49	0.49	0.50	0.42	0.43	0.43	0.42	0.42	0.40	0.38	0.38	0.38	0.38	0.38	
8		0.67	0.66	0.67	0.55	0.55	0.57	0.57	0.57	0.48	0.49	0.50	0.49	0.49	0.46	0.45	0.45	0.45	0.45	0.45	
9		0.76	0.76	0.76	0.63	0.63	0.65	0.65	0.65	0.55	0.55	0.57	0.56	0.56	0.52	0.51	0.51	0.51	0.51	0.51	
10		0.85	0.85	0.85	0.70	0.70	0.73	0.73	0.73	0.61	0.62	0.64	0.63	0.63	0.58	0.57	0.57	0.57	0.57	0.57	
11		0.94	0.94	0.94	0.78	0.78	0.80	0.80	0.81	0.68	0.68	0.71	0.70	0.70	0.64	0.63	0.63	0.63	0.63	0.63	
12		1.00	1.00	1.00	0.85	0.85	0.88	0.88	0.88	0.74	0.74	0.78	0.77	0.77	0.70	0.70	0.70	0.70	0.70	0.70	
13					0.93	0.93	0.96	0.96	0.96	0.81	0.81	0.85	0.84	0.84	0.76	0.76	0.76	0.76	0.76	0.76	
14					1.00	1.00	1.00	1.00	1.00	0.87	0.87	0.91	0.91	0.91	0.82	0.82	0.82	0.82	0.82	0.82	
15										0.94	0.94	0.98	0.98	0.98	0.89	0.88	0.88	0.88	0.88	0.88	
16										1.00	1.00	1.00	1.00	1.00	0.95	0.95	0.95	0.95	0.95	0.95	
17															1.00	1.00	1.00	1.00	1.00	1.00	

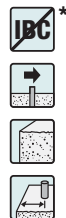

- E = Embedment depth (inches).
- C_{act} = actual edge distance at which anchor is installed (inches).
- C_{cr} = critical edge distance for 100% load (inches).
- C_{min} = minimum edge distance for reduced load (inches).
- f_c = adjustment factor for allowable load at actual edge distance.
 $f_{c_{cr}}$ = adjustment factor for allowable load at critical edge distance.
 $f_{c_{cr}}$ is always = 1.00.
- f_{cmin} = adjustment factor for allowable load at minimum edge distance.
- $f_c = f_{cmin} + [(1 - f_{cmin}) (C_{act} - C_{min}) / (C_{cr} - C_{min})]$.

* See page 12 for an explanation of the load table icons.

AT Design Information — Concrete

AT Allowable Load Adjustment Factors in Normal-Weight Concrete: Spacing, Tension Load

How to use these charts

1. The following tables are for reduced spacing.
2. Locate the anchor size to be used for either a tension and/or shear load application.
3. Locate the embedment (E) at which the anchor is to be installed.
4. Locate the spacing (s_{act}) at which the anchor is to be installed.
5. The load-adjustment factor (f_s) is the intersection of the row and column.
6. Multiply the allowable load by the applicable load-adjustment factor.
7. Reduction factors for multiple spacings are multiplied together.
8. Adjustment factors do not apply to allowable steel strength values
9. Adjustment factors are to be applied to allowable tension load based on bond strength values only.

Spacing Tension (f_s)

s_{act} (in.)	Dia.	3/8			1/2			5/8			3/4		
	Rebar	#3	#4	#4	#4	#5	#5	#6	#6	#6	#6		
E	1 3/4	3 1/2	4 1/2	2 1/8	4 1/4	6	7 1/2	2 1/2	5 1/2	9 3/8	3 3/8	6 3/4	11 1/4
s_{cr}	7	6 1/8	18	8 1/2	7 1/2	24	30	10	9 5/8	37 1/2	13 1/2	11 7/8	45
s_{min}	7/8	1 3/4	2 1/4	1 1/8	2 1/8	3	3 3/4	1 1/4	2 3/4	4 3/4	1 3/4	3 3/8	5 5/8
f_{smin}	0.57	0.58	0.80	0.57	0.58	0.80	0.80	0.57	0.58	0.80	0.57	0.58	0.80
7/8	0.57												
1	0.58												
1 1/2	0.61			0.59				0.58					
2	0.65	0.60		0.62				0.61			0.58		
2 1/2	0.68	0.64	0.80	0.65	0.61			0.63			0.60		
3	0.72	0.68	0.81	0.67	0.64	0.80		0.66	0.59		0.61		
3 1/2	0.75	0.72	0.82	0.70	0.68	0.80		0.68	0.62		0.63	0.59	
4	0.79	0.76	0.82	0.73	0.71	0.81	0.80	0.71	0.65		0.65	0.61	
5	0.86	0.84	0.83	0.78	0.79	0.82	0.81	0.75	0.71	0.80	0.68	0.66	
6	0.93	0.92	0.85	0.84	0.86	0.83	0.82	0.80	0.77	0.81	0.72	0.71	0.80
7	1.00	1.00	0.86	0.89	0.93	0.84	0.82	0.85	0.83	0.81	0.75	0.76	0.81
8			0.87	0.95	1.00	0.85	0.83	0.90	0.88	0.82	0.79	0.81	0.81
9			0.89	1.00		0.86	0.84	0.95	0.94	0.82	0.82	0.85	0.82
10			0.90			0.87	0.84	1.00	1.00	0.83	0.86	0.90	0.82
12			0.92			0.89	0.86			0.84	0.93	1.00	0.83
14			0.95			0.90	0.87			0.85	1.00		0.84
16			0.97			0.92	0.89			0.86			0.85
18			1.00			0.94	0.90			0.88			0.86
20						0.96	0.92			0.89			0.87
24						1.00	0.94			0.91			0.89
28							0.97			0.93			0.91
32							1.00			0.95			0.93
36										0.98			0.95
40										1.00			0.97
45													1.00

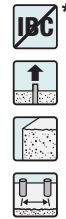

Adhesive Anchors

7/8" – 1 1/4"
diameters
on next
page →

1. E = Embedment depth (inches).
2. s_{act} = actual spacing distance at which anchors are installed (inches).
3. s_{cr} = critical spacing distance for 100% load (inches).
4. s_{min} = minimum spacing distance for reduced load (inches).
5. f_s = adjustment factor for allowable load at actual spacing distance.
6. f_{scr} = adjustment factor for allowable load at critical spacing distance. f_{scr} is always = 1.00.
7. f_{smin} = adjustment factor for allowable load at minimum spacing distance.
8. $f_s = f_{smin} + [(1 - f_{smin}) (s_{act} - s_{min}) / (s_{cr} - s_{min})]$.

* See page 12 for an explanation of the load table icons.

AT Design Information — Concrete

Spacing Tension (f_s) (continued)

s_{act} (in.)	Di.	¾			1			1½			1¾			
	Rebar	#7			#8			#9			#10			#11
	E	3¾	7¼	13⅞	4½	9	15	5⅞	10⅞	16⅞	5⅞	11¼	18¾	20⅞
	s_{cr}	15½	13⅞	52½	18	15¾	60	20½	17¾	67½	22½	19¾	75	82½
s_{min}	2	3⅞	6⅞	2¼	4½	7½	2⅞	5⅞	8½	2⅞	5⅞	9⅞	10⅞	
f_{smin}	0.57	0.58	0.80	0.57	0.58	0.80	0.57	0.58	0.80	0.57	0.58	0.80	0.80	
2		0.57												
3		0.60			0.59			0.58			0.57			
4		0.63	0.59		0.62			0.60			0.59			
5		0.67	0.63		0.65	0.60		0.63			0.62			
6		0.70	0.67		0.67	0.64		0.65	0.61		0.64	0.59		
8		0.76	0.76	0.81	0.73	0.71	0.80	0.70	0.68		0.68	0.65		
10		0.82	0.84	0.81	0.78	0.79	0.81	0.75	0.74	0.81	0.73	0.71	0.80	
12		0.89	0.93	0.82	0.84	0.86	0.82	0.80	0.81	0.81	0.77	0.77	0.81	0.80
14		0.95	1.00	0.83	0.89	0.93	0.82	0.84	0.88	0.82	0.81	0.83	0.81	0.81
16		1.00		0.84	0.95	1.00	0.83	0.89	0.94	0.83	0.86	0.89	0.82	0.82
20				0.86	1.00		0.85	0.99	1.00	0.84	0.95	1.00	0.83	0.83
24				0.88			0.86	1.00		0.85	1.00		0.84	0.84
28				0.89			0.88			0.87			0.86	0.85
32				0.91			0.89			0.88			0.87	0.86
36				0.93			0.91			0.89			0.88	0.87
40				0.95			0.92			0.91			0.89	0.88
50				0.99			0.96			0.94			0.92	0.91
60				1.00			1.00			0.97			0.95	0.94
70										1.00			0.98	0.97
80													1.00	0.99
83														1.00

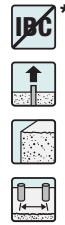

Adhesive Anchors

See notes on previous page.

AT Allowable Load Adjustment Factors in Normal-Weight Concrete: Spacing, Shear Load

How to use these charts

- The following tables are for reduced spacing.
- Locate the anchor size to be used for either a tension and/or shear load application.
- Locate the embedment (E) at which the anchor is to be installed.
- Locate the spacing (s_{act}) at which the anchor is to be installed.
- The load-adjustment factor (f_s) is the intersection of the row and column.
- Multiply the allowable load by the applicable load-adjustment factor.
- Reduction factors for multiple spacings are multiplied together.
- Adjustment factors do not apply to allowable steel strength values.
- Adjustment factors are to be applied to allowable shear load based on concrete edge distance values only.

Spacing Shear (f_s)

s_{act} (in.)	Di.	¾		½		⅝		¾		⅞		1	1½		1¾		
	Rebar	#3		#4		#5		#6		#7		#8	#9		#10		
	E	1¾	3½	2⅞	4¼	2½	5½	3⅞	6¾	3⅞	7¾	4½	9	5⅞	10⅞	5⅞	11¼
	s_{cr}	2⅞	5¼	3¼	6⅞	3¾	8¼	5⅞	10⅞	5⅞	11⅞	6¾	13½	7¾	15¼	8½	16⅞
s_{min}	⅞	1¾	1⅞	2⅞	1¼	2¾	1¼	3⅞	2	3⅞	2¼	4½	2⅞	5⅞	2⅞	5⅞	
f_{smin}	0.90	0.83	0.90	0.83	0.90	0.83	0.90	0.83	0.90	0.83	0.90	0.83	0.90	0.83	0.90	0.83	
¾		0.90															
1		0.91															
1½		0.94		0.92		0.91											
2		0.96	0.84	0.94		0.93		0.91		0.90							
2½		0.99	0.87	0.96	0.85	0.95		0.92		0.91		0.91					
3		1.00	0.89	0.99	0.87	0.97	0.84	0.94		0.93		0.92		0.91		0.90	
3½			0.92	1.00	0.89	0.99	0.85	0.95	0.83	0.94		0.93		0.92		0.91	
4			0.94		0.91	1.00	0.87	0.97	0.85	0.95	0.83	0.94		0.93		0.92	
5			0.99		0.95		0.90	1.00	0.87	0.98	0.85	0.96	0.84	0.95		0.94	
6			1.00		0.99		0.93		0.90	1.00	0.88	0.98	0.86	0.97	0.84	0.96	0.84
7					1.00		0.96		0.92		0.90	1.00	0.88	0.99	0.86	0.97	0.85
8							0.99		0.95		0.92		0.90	1.00	0.88	0.99	0.87
9							1.00		0.97		0.94		0.92		0.90	1.00	0.88
10									0.97		0.94		0.92		0.90	1.00	0.88
12									1.00		0.96		0.93		0.91		0.90
14											1.00		0.97		0.95		0.93
16													1.00		0.98		0.96
17															1.00		0.99

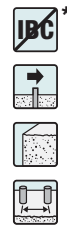

- E = Embedment depth (inches).
- s_{act} = actual spacing distance at which anchors are installed (inches).
- s_{cr} = critical spacing distance for 100% load (inches).
- s_{min} = minimum spacing distance for reduced load (inches).
- f_s = adjustment factor for allowable load at actual spacing distance.
- $f_{s,cr}$ = adjustment factor for allowable load at critical spacing distance. $f_{s,cr}$ is always = 1.00.
- $f_{s,min}$ = adjustment factor for allowable load at minimum spacing distance.
- $f_s = f_{s,min} + [(1 - f_{s,min}) (s_{act} - s_{min}) / (s_{cr} - s_{min})]$.

* See page 12 for an explanation of the load table icons.

AT Design Information — Concrete

AT Allowable Load Adjustment Factors in Sand-Lightweight Concrete: Edge Distance, Tension and Shear Loads

How to use these charts

1. The following tables are for reduced edge distance only.
2. Locate the anchor size to be used for either a tension and/or shear load application.
3. Locate the embedment (E) at which the anchor is to be installed.
4. Locate the edge distance (C_{act}) at which the anchor is to be installed.
5. The load-adjustment factor (f_c) is the intersection of the row and column.
6. Multiply the allowable load by the applicable load-adjustment factor.
7. Reduction factors for multiple edges are multiplied together.
8. Adjustment factors do not apply to allowable steel strength values.
9. Adjustment factors are to be applied to allowable tension load based on bond strength values or allowable shear load based on concrete edge distance values only.

Edge Distance Tension (f_c)

Edge Dist. C_{act} (in.)	Dia.	¾		½		⅝	
	E	1¼	3½	2⅝	4¼	2½	5
	C_{cr}	2⅝	5¼	3⅝	6⅝	3¾	7½
	C_{min}	1¾	1¾	1¾	1¾	1¾	1¾
	f_{cmin}	0.59	0.59	0.50	0.50	0.50	0.50
1¼		0.59	0.59	0.50	0.50	0.50	0.50
2		0.71	0.62	0.59	0.53	0.56	0.52
2¼		0.82	0.65	0.68	0.55	0.63	0.54
2½		0.94	0.68	0.77	0.58	0.69	0.57
2¾		1.00	0.71	0.86	0.61	0.75	0.59
3			0.74	0.95	0.64	0.81	0.61
3¼			0.77	1.00	0.66	0.88	0.63
3½			0.80		0.69	0.94	0.65
3¾			0.82		0.72	1.00	0.67
4			0.85		0.74		0.70
4¼			0.88		0.77		0.72
4½			0.91		0.80		0.74
4¾			0.94		0.82		0.76
5			0.97		0.85		0.78
5¼			1.00		0.88		0.80
5½					0.91		0.83
5¾					0.93		0.85
6					0.96		0.87
6¼					0.99		0.89
6½					1.00		0.91
6¾							0.93
7							0.96
7¼							0.98
7½							1.00

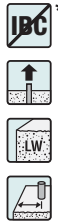

Edge Distance Shear (f_c)

Edge Dist. C_{act} (in.)	Dia.	¾		½		⅝	
	E	1¼	3½	2⅝	4¼	2½	5
	C_{cr}	2⅝	5¼	3⅝	6⅝	3¾	7½
	C_{min}	1¾	1¾	1¾	1¾	1¾	1¾
	f_{cmin}	0.40	0.35	0.18	0.15	0.12	0.11
1¼		0.40	0.35	0.18	0.15	0.12	0.11
2		0.57	0.40	0.33	0.20	0.23	0.15
2¼		0.74	0.44	0.48	0.24	0.34	0.19
2½		0.91	0.49	0.63	0.29	0.45	0.23
2¾		1.00	0.54	0.78	0.33	0.56	0.26
3			0.58	0.93	0.38	0.67	0.30
3¼			0.63	1.00	0.43	0.78	0.34
3½			0.68		0.47	0.89	0.38
3¾			0.72		0.52	1.00	0.42
4			0.77		0.56		0.46
4¼			0.81		0.61		0.50
4½			0.86		0.66		0.54
4¾			0.91		0.70		0.57
5			0.95		0.75		0.61
5¼			1.00		0.79		0.65
5½					0.84		0.69
5¾					0.89		0.73
6					0.93		0.77
6¼					0.98		0.81
6½					1.00		0.85
6¾							0.88
7							0.92
7¼							0.96
7½							1.00



1. E = Embedment depth (inches).
2. C_{act} = actual edge distance at which anchor is installed (inches).
3. C_{cr} = critical edge distance for 100% load (inches).
4. C_{min} = minimum edge distance for reduced load (inches).
5. f_c = adjustment factor for allowable load at actual edge distance.
6. f_{ocr} = adjustment factor for allowable load at critical edge distance. f_{ocr} is always = 1.00.
7. f_{cmin} = adjustment factor for allowable load at minimum edge distance.
8. $f_c = f_{cmin} + [(1 - f_{cmin}) (C_{act} - C_{min}) / (C_{cr} - C_{min})]$.

* See page 12 for an explanation of the load table icons.

SET Epoxy Adhesive

SET is a high-strength, non-shrink, epoxy-based adhesive formulated for anchoring and doweling threaded rod and rebar. Resin and hardener are dispensed and mixed simultaneously through the mixing nozzle.

Features

- Code listed under the IBC/IRC for URM per ICC-ES ESR-1772
- Meets or exceeds the requirements of ASTM C881 specification for Type I and IV, Grade 3, Class C
- Cure times – 24 hours at 65°F, 72 hours at 40°F
- Easy hole-cleaning procedure – no power-brushing required
- Suitable for use in damp or wet anchor sites
- When properly mixed, adhesive will be a uniform gray color
- Available in 22 oz. and 56 oz. cartridges for application versatility
- Manufactured in the USA using global materials

Applications

- Threaded rod anchoring and rebar doweling into concrete, masonry and URM (red brick)
- Pick-proof sealant around doors, windows and fixtures
- Paste-over for crack injection preparation
- Bonding hardened concrete to hardened concrete
- CalTrans and multiple DOT listings; refer to www.strongtie.com/DOT

Codes: ICC-ES ESR-1772 (unreinforced masonry); Florida FL15730.5; AASHTO M-235 and ASTM C881 (Type I and IV, Grade 3, Class C); CalTrans Approved; Multiple DOT listings; NSF/ANSI Standard 61 (216 in.²/1,000 gal.)

Chemical Resistance

See pages 320–321.

Installation and Application Instructions

(See also pages 124–127.)

- Surfaces to receive epoxy must be clean.
- Base material temperature must be 40°F or above at the time of installation. For best results, material should be 70°–80°F at time of application.
- To warm cold material, store cartridges in a warm, uniformly heated area or storage container. Do not immerse cartridges in water to facilitate warming.
- Mixed material in nozzle can harden in 30 minutes at temperatures of 70°F and above.

Design Example

See page 324.

Suggested Specifications

See www.strongtie.com for more information.



SET Adhesive

SET Epoxy Adhesive

Test Criteria

Anchors installed with SET adhesive have been tested in accordance with ICC-ES *Acceptance Criteria for Anchors in Unreinforced Masonry Elements (AC60)*.

Property	Test Method	Result*
Consistency	ASTM C881	Non-sag/thixotropic paste
Heat deflection temperature	ASTM D648	136°F (58°C)
Bond strength (moist cure)	ASTM C882	3,218 psi (2 days) 3,366 psi (14 days)
Water absorption	ASTM D570	0.11% (24 hours)
Compressive yield strength	ASTM D695	5,065 psi (24 hours) 12,650 psi (7 days)
Compressive modulus	ASTM D695	439,000 psi (7 days)
Shore D Durometer	ASTM D2240	81
Gel time (75°F)	ASTM C881	30 minutes – 60 gram mass 60 minutes – thin film
VOC	ASTM D2369	6 g/L

*Material and curing conditions: 73 ± 2°F, unless otherwise noted.

SET Cartridge System

Model No.	Capacity (ounces)	Cartridge Type	Carton Quantity	Dispensing Tools	Mixing Nozzle
SET22	22	Side-by-side	10	EDT22S, EDTA22CKT	EMN22i
SET22-N ⁴	22	Side-by-side	10	EDTA22P	EMN22i
SET56	56	Side-by-side	6	EDTA56P	EMN50

1. Cartridge estimation guidelines are available at www.strongtie.com/apps.
2. Detailed information on dispensing tools, mixing nozzles and other adhesive accessories is available on pages 128 through 135, or at www.strongtie.com.
3. Use only Simpson Strong-Tie® mixing nozzles in accordance with Simpson Strong-Tie instructions. Modification or improper use of mixing nozzle may impair SET adhesive performance.
4. One EMN22i mixing nozzle and one nozzle extension are supplied with each cartridge.

Cure Schedule

Base Material Temperature		Cure Time (hrs.)
°F	°C	
40	4	72
65	18	24
85	29	20
90	32	16

For water-saturated concrete (including damp and water-filled holes), the cure times must be doubled.

In-Service Temperature Sensitivity

Base Material Temperature		Percent Allowable Load
°F	°C	
40	4	100%
70	21	100%
110	43	100%
135	57	75%
150	66	44%
180	82	20%

1. Refer to temperature sensitivity chart for allowable bond strength reduction for temperature. See page 319 for more information.
2. Percent allowable load may be linearly interpolated for intermediate base material temperatures.
3. °C = (°F-32) / 1.8

SET Design Information — Concrete

SET Allowable Tension Loads for Threaded Rod Anchors in Normal-Weight Concrete
(continued on next page)

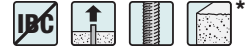

Adhesive Anchors

Rod Dia. in. (mm)	Drill Bit Dia. in.	Embed. Depth in. (mm)	Critical Edge Dist. in. (mm)	Critical Spacing Dist. in. (mm)	Tension Load Based on Bond Strength						Tension Load Based on Steel Strength		
					f' _c ≥ 2,000 psi (13.8 MPa) Concrete			f' _c ≥ 4,000 psi (27.6 MPa) Concrete			F1554 Grade 36	A193 GR B7	F593 304SS
					Ultimate lb. (kN)	Std. Dev. lb. (kN)	Allow. lb. (kN)	Ultimate lb. (kN)	Std. Dev. lb. (kN)	Allow. lb. (kN)	Allow. lb. (kN)	Allow. lb. (kN)	Allow. lb. (kN)
3/8 (9.5)	1/2	1 1/4 (44)	2 5/8 (67)	7 (178)	1,900 (8.5)	485 (2.2)	475 (2.1)	1,900 (8.5)	—	475 (2.1)	2,105 (9.4)	4,535 (20.2)	3,630 (16.1)
		3 1/2 (89)	5 1/4 (133)	14 (356)	10,200 (45.4)	119 (0.5)	2,550 (11.3)	10,280 (45.7)	97 (0.4)	2,570 (11.4)			
		4 1/2 (114)	6 3/4 (171)	18 (457)	10,613 (47.2)	84 (0.4)	2,655 (11.8)	10,613 (47.2)	—	2,655 (11.8)			
1/2 (12.7)	5/8	2 1/8 (54)	3 3/16 (81)	8 1/2 (216)	7,216 (32.1)	1,163 (5.2)	1,805 (8.0)	7,216 (32.1)	—	1,805 (8.0)	3,750 (16.7)	8,080 (35.9)	6,470 (28.8)
		4 1/4 (108)	6 3/8 (162)	17 (432)	17,700 (78.7)	629 (2.8)	4,425 (19.7)	18,400 (81.8)	788 (3.5)	4,600 (20.5)			
		6 (152)	9 (229)	24 (610)	18,556 (82.5)	853 (3.8)	4,640 (20.6)	18,556 (82.5)	—	4,640 (20.6)			
5/8 (15.9)	3/4	2 1/2 (64)	3 3/4 (95)	10 (254)	6,780 (30.2)	315 (1.4)	1,695 (7.5)	6,780 (30.2)	—	1,695 (7.5)	5,875 (26.1)	12,660 (56.3)	10,120 (45.0)
		3 3/4 (95)	5 5/8 (143)	15 (381)	—	—	4,190 (18.6)	—	—	4,875 (21.7)			
		5 (127)	7 1/2 (191)	20 (508)	26,700 (118.8)	1,121 (5.0)	6,680 (29.7)	32,200 (143.2)	964 (4.3)	8,050 (35.8)			
		7 3/16 (183)	10 7/8 (276)	28 3/4 (730)	—	—	7,515 (33.4)	—	—	8,200 (36.5)			
		9 9/16 (238)	14 1/8 (359)	37 1/2 (953)	33,402 (148.6)	1,198 (5.3)	8,350 (37.1)	33,402 (148.6)	—	8,350 (37.1)			
3/4 (19.1)	7/8	3 3/8 (86)	5 1/16 (129)	13 1/2 (343)	15,456 (68.8)	2,621 (11.7)	3,865 (17.2)	15,456 (68.8)	—	3,865 (17.2)	8,460 (37.6)	18,230 (81.1)	12,400 (55.2)
		5 1/16 (129)	7 7/8 (194)	20 1/4 (514)	—	—	7,195 (32.0)	—	—	7,245 (32.2)			
		6 3/4 (171)	10 1/8 (257)	27 (686)	42,100 (187.3)	1,945 (8.7)	10,525 (46.8)	42,480 (189.0)	1,575 (7.0)	10,620 (47.2)			
		9 (229)	13 1/2 (343)	36 (914)	—	—	11,220 (49.9)	—	—	11,265 (50.1)			
		11 1/4 (286)	16 7/8 (429)	45 (1143)	47,634 (211.9)	608 (2.7)	11,910 (53.0)	47,634 (211.9)	—	11,910 (53.0)			

See notes on next page.

7/8" – 1 1/4" diameters on next page →

* See page 12 for an explanation of the load table icons.

SET Design Information — Concrete

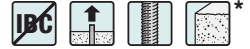
SET Allowable Tension Loads for Threaded Rod Anchors in Normal-Weight Concrete
(continued from previous page)

Rod Dia. in. (mm)	Drill Bit Dia. in.	Embed. Depth in. (mm)	Critical Edge Dist. in. (mm)	Critical Spacing Dist. in. (mm)	Tension Load Based on Bond Strength						Tension Load Based on Steel Strength		
					$f'_c \geq 2,000$ psi (13.8 MPa) Concrete			$f'_c \geq 4,000$ psi (27.6 MPa) Concrete			F1554 Grade 36	A193 GR B7	F593 304SS
					Ultimate lb. (kN)	Std. Dev. lb. (kN)	Allow. lb. (kN)	Ultimate lb. (kN)	Std. Dev. lb. (kN)	Allow. lb. (kN)	Allow. lb. (kN)	Allow. lb. (kN)	Allow. lb. (kN)
7/8 (22.2)	1	3 7/8 (98)	5 1/16 (148)	15 1/2 (394)	19,120 (85.1)	1,239 (5.5)	4,780 (21.3)	19,120 (85.1)	—	4,780 (21.3)	11,500 (51.2)	24,785 (110.2)	16,860 (75.0)
		5 1/16 (148)	8 3/4 (222)	23 1/4 (591)	—	—	8,535 (38.0)	—	—	9,250 (41.1)			
		7 3/4 (197)	11 5/8 (295)	31 (787)	49,160 (218.7)	2,149 (9.6)	12,290 (54.7)	54,880 (244.1)	1,050 (4.7)	13,720 (61.0)			
		10 7/16 (265)	15 5/8 (397)	41 3/4 (1060)	—	—	14,480 (64.4)	—	—	15,195 (67.6)			
		13 3/8 (333)	19 5/8 (498)	52 1/2 (1334)	66,679 (296.6)	506 (2.3)	16,670 (74.2)	66,679 (296.6)	—	16,670 (74.2)			
1 (25.4)	1 1/8	4 1/2 (114)	6 3/4 (171)	18 (457)	20,076 (89.3)	2,388 (10.6)	5,020 (22.3)	20,076 (89.3)	—	5,020 (22.3)	15,025 (66.8)	32,380 (144.0)	22,020 (97.9)
		6 3/4 (171)	10 1/8 (257)	27 (686)	—	—	10,020 (44.6)	—	—	10,640 (47.3)			
		9 (229)	13 1/2 (343)	36 (914)	60,060 (267.2)	5,472 (24.3)	15,015 (66.8)	65,020 (289.2)	2,924 (13.0)	16,255 (72.3)			
		12 (305)	18 (457)	48 (1219)	—	—	17,810 (79.2)	—	—	18,430 (82.0)			
		15 (381)	22 1/2 (572)	60 (1524)	82,401 (366.5)	6,432 (28.6)	20,600 (91.6)	82,401 (366.5)	—	20,600 (91.6)			
1 1/8 (28.6)	1 1/4	5 1/8 (130)	7 3/4 (197)	20 1/2 (521)	27,560 (122.6)	—	6,890 (30.6)	27,560 (122.6)	—	6,890 (30.6)	19,025 (84.6)	41,000 (182.4)	27,880 (124.0)
		7 5/8 (194)	11 1/2 (292)	30 1/2 (775)	—	—	12,105 (53.8)	—	—	12,500 (55.6)			
		10 5/8 (257)	15 1/4 (387)	40 1/2 (1029)	69,200 (307.8)	—	17,300 (77.0)	72,340 (321.8)	—	18,085 (80.4)			
		13 1/2 (343)	20 1/4 (514)	54 (1372)	—	—	21,380 (95.1)	—	—	21,770 (96.8)			
		16 7/8 (429)	25 3/8 (645)	67 1/2 (1715)	101,820 (452.9)	—	25,455 (113.2)	101,820 (452.9)	—	25,455 (113.2)			
1 1/4 (31.8)	1 3/8	5 5/8 (143)	8 7/16 (214)	22 1/2 (572)	35,858 (159.5)	2,389 (10.6)	8,965 (39.9)	35,858 (159.5)	—	8,965 (39.9)	23,490 (104.5)	50,620 (225.2)	34,425 (153.1)
		8 7/16 (214)	12 3/4 (324)	33 3/4 (857)	—	—	14,115 (62.8)	—	—	14,115 (62.8)			
		11 1/4 (286)	16 7/8 (429)	45 (1143)	77,045 (342.7)	7,024 (31.2)	19,260 (85.7)	77,045 (342.7)	—	19,260 (85.7)			
		15 (381)	22 1/2 (572)	60 (1524)	—	—	24,965 (111.0)	—	—	24,965 (111.0)			
		18 3/4 (476)	28 1/8 (714)	75 (1905)	122,681 (545.7)	10,940 (48.7)	30,670 (136.4)	122,681 (545.7)	—	30,670 (136.4)			

Adhesive Anchors

- Allowable load must be the lesser of the bond or steel strength.
- The allowable loads listed under allowable bond are based on a safety factor of 4.0.
- Refer to allowable load-adjustment factors for spacing and edge distance on pages 116 and 118.
- Refer to in-service temperature sensitivity chart for allowable load adjustment for temperature.
- Anchors are permitted to be used within fire-resistive construction, provided the anchors resist wind or seismic loads only. For use in fire-resistive construction, the anchors can also be permitted to be used to resist gravity loads, provided special consideration has been given to fire-exposure conditions.
- Anchors are not permitted to resist tension forces in overhead or wall installations unless proper consideration is given to fire-exposure and elevated-temperature conditions.
- Allowable load based on bond strength may be interpolated for concrete compressive strengths between 2,000 psi and 4,000 psi.

* See page 12 for an explanation of the load table icons.

SET Design Information — Concrete

SET Allowable Shear Loads for Threaded Rod Anchors in Normal-Weight Concrete



Adhesive Anchors

Rod Dia. in. (mm)	Drill Bit Dia. in.	Embed. Depth in. (mm)	Critical Edge Dist. in. (mm)	Critical Spacing Dist. in. (mm)	Shear Load Based on Concrete Edge Distance			Shear Load Based on Steel Strength		
					f' _c ≥ 2,000 psi (13.8 MPa) Concrete			F1554 Grade 36	A193 GR B7	F593 304SS
					Ultimate lb. (kN)	Std. Dev. lb. (kN)	Allowable lb. (kN)	Allowable lb. (kN)	Allowable lb. (kN)	Allowable lb. (kN)
3/8 (9.5)	1/2	1 3/4 (44)	5 1/4 (133)	2 5/8 (67)	4,573 (20.3)	317 (1.4)	1,145 (5.1)	1,085 (4.8)	2,340 (10.4)	1,870 (8.3)
		3 1/2 (89)		5 1/4 (133)	6,935 (30.8)	965 (4.3)	1,735 (7.7)			
		4 1/2 (114)		5 1/4 (133)	—	—	1,735 (7.7)			
1/2 (12.7)	5/8	2 1/8 (54)	6 3/8 (162)	3 1/4 (83)	7,001 (31.1)	437 (1.9)	1,750 (7.8)	1,930 (8.6)	4,160 (18.5)	3,330 (14.8)
		4 1/4 (108)		6 3/8 (162)	11,116 (49.4)	1,696 (7.5)	2,780 (12.4)			
		6 (152)		6 3/8 (162)	—	—	2,780 (12.4)			
5/8 (15.9)	3/4	2 1/2 (64)	7 1/2 (191)	3 3/4 (95)	14,427 (64.2)	826 (3.7)	3,605 (16.0)	3,025 (13.5)	6,520 (29.0)	5,220 (23.2)
		5 (127)		7 1/2 (191)	19,501 (86.7)	1,027 (4.6)	4,875 (21.7)			
		9 3/8 (238)		7 1/2 (191)	—	—	4,875 (21.7)			
3/4 (19.1)	7/8	3 3/8 (86)	10 1/8 (257)	5 1/8 (130)	21,180 (94.2)	942 (4.2)	5,295 (23.6)	4,360 (19.4)	9,390 (41.8)	6,385 (28.4)
		6 3/4 (171)		10 1/8 (257)	25,244 (112.3)	2,538 (11.3)	6,310 (28.1)			
		11 1/4 (286)		10 1/8 (257)	—	—	6,310 (28.1)			
7/8 (22.2)	1	3 7/8 (98)	11 5/8 (295)	5 7/8 (149)	28,333 (126.0)	2,406 (10.7)	7,085 (31.5)	5,925 (26.4)	12,770 (56.8)	8,685 (38.6)
		7 3/4 (197)		11 5/8 (295)	33,533 (149.2)	2,793 (12.4)	8,385 (37.3)			
		13 1/8 (333)		11 5/8 (295)	—	—	8,385 (37.3)			
1 (25.4)	1 1/8	4 1/2 (114)	13 1/2 (343)	6 3/4 (171)	30,520 (135.8)	2,166 (9.6)	7,630 (33.9)	7,740 (34.4)	16,680 (74.2)	11,345 (50.5)
		9 (229)		13 1/2 (343)	50,187 (223.2)	2,176 (9.7)	12,545 (55.8)			
		15 (381)		13 1/2 (343)	—	—	12,545 (55.8)			
1 1/8 (28.6)	1 1/4	5 1/8 (130)	15 1/4 (387)	7 3/4 (197)	41,325 (183.8)	—	10,330 (46.0)	9,800 (43.6)	21,125 (94.0)	14,365 (63.9)
		10 1/8 (257)		15 1/4 (387)	58,285 (259.3)	—	14,570 (64.8)			
		16 7/8 (429)		15 1/4 (387)	—	—	14,570 (64.8)			
1 1/4 (31.8)	1 3/8	5 5/8 (143)	16 7/8 (429)	8 1/2 (216)	52,130 (231.9)	3,969 (17.7)	13,035 (58.0)	12,100 (53.8)	26,075 (116.0)	17,730 (78.9)
		11 1/4 (286)		16 7/8 (429)	66,383 (295.3)	3,948 (17.6)	16,595 (73.8)			
		18 3/4 (476)		16 7/8 (429)	—	—	16,595 (73.8)			

1. Allowable load must be the lesser of the load based on concrete edge distance or steel strength.
2. The allowable loads based on concrete edge distance are based on a safety factor of 4.0.
3. Refer to allowable load-adjustment factors for spacing and edge distance on pages 117 and 119.
4. Refer to in-service temperature sensitivity chart for allowable load adjustment for temperature.
5. Anchors are permitted to be used within fire-resistive construction, provided the anchors resist wind or seismic loads only. For use in fire-resistive construction, the anchors can also be permitted to be used to resist gravity loads, provided special consideration has been given to fire-exposure conditions.

* See page 12 for an explanation of the load table icons.

SET Design Information — Concrete

SET Allowable Tension Loads for Threaded Rod Anchors in Normal-Weight Concrete Stemwall

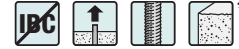

Rod Dia. in. (mm)	Drill Bit Dia. in.	Embed. Depth in. (mm)	Stemwall Width in. (mm)	Min. Edge Dist. in. (mm)	Min. End Dist. in. (mm)	Tension Load Based on Bond Strength		Tension Load Based on Steel Strength	
						$f'_c \geq 2,500$ psi (17.2 MPa) Concrete			F1554 Grade 36
						Ultimate lb. (kN)	Allowable lb. (kN)	Allowable lb. (kN)	
5/8 (15.9)	3/4	10 (254.0)	6 (152.4)	1 3/4 (44.5)	5 (127.0)	13,634 (60.6)	3,410 (15.2)	5,875 (26.1)	
7/8 (22.2)	1	15 (381.0)	8 (203.2)	1 3/4 (44.5)	5 (127.0)	22,664 (100.8)	5,665 (25.2)	11,500 (51.2)	

1. Allowable load must be the lesser of the bond or steel strength.
2. The allowable loads listed under allowable bond are based on a safety factor of 4.0.
3. Refer to in-service temperature sensitivity chart for allowable load adjustment for temperature.
4. Anchors are permitted to be used within fire-resistive construction, provided the anchors resist wind or seismic loads only. For use in fire-resistive construction, the anchors can also be permitted to be used to resist gravity loads, provided special consideration has been given to fire-exposure conditions.

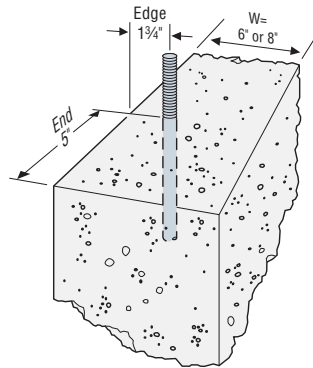

Edge and end distances for threaded rod in concrete foundation stemwall corner installation

SET Allowable Shear Loads for Threaded Rod Anchors in Normal-Weight Concrete, Load Applied Parallel to Concrete Edge



Rod Dia. in. (mm)	Drill Bit Dia. in.	Embed. Depth in. (mm)	Min. Edge Dist. in. (mm)	Min. End Dist. in. (mm)	Shear Load Based on Concrete Edge Distance			Shear Load Based on Steel Strength
					$f'_c \geq 2,000$ psi (13.8 MPa) Concrete			F1554 Grade 36
					Ultimate lb. (kN)	Std. Dev. lb. (kN)	Allowable lb. (kN)	Allowable lb. (kN)
1/2 (12.7)	5/8	4 1/4 (108.0)	1 3/4 (44.5)	8 1/2 (219.9)	8,496 (37.8)	654 (2.9)	2,125 (9.5)	1,930 (8.6)
5/8 (15.9)	3/4	5 (127.0)	1 3/4 (44.5)	10 (254.0)	8,857 (39.4)	225 (1.0)	2,215 (9.9)	3,025 (13.5)

1. Allowable load must be the lesser of the load based on concrete edge distance, steel strength or wood bearing capacity.
2. The allowable loads based on concrete edge distance are based on a safety factor of 4.0.
3. Refer to allowable load-adjustment factors for spacing on page 119.
4. Refer to in-service temperature sensitivity chart for allowable load adjustment for temperature.
5. Anchors are permitted to be used within fire-resistive construction, provided the anchors resist wind or seismic loads only. For use in fire-resistive construction, the anchors can also be permitted to be used to resist gravity loads, provided special consideration has been given to fire-exposure conditions.

* See page 12 for an explanation of the load table icons.

SET Design Information — Concrete

SET Allowable Tension Loads for Rebar Dowels in Normal-Weight Concrete



Rebar Size No. (mm)	Drill Bit Dia. in.	Embed. Depth in. (mm)	Critical Edge Dist. in. (mm)	Critical Spacing Dist. in. (mm)	Tension Load Based on Bond Strength						Tension Load Based on Steel Strength
					$f'_c \geq 2,000$ psi (13.8 MPa) Concrete			$f'_c > 4,000$ psi (27.6 MPa) Concrete			ASTM A615 Grade 60 Rebar
					Ultimate lb. (kN)	Std. Dev. lb. (kN)	Allow. lb. (kN)	Ultimate lb. (kN)	Std. Dev. lb. (kN)	Allow. lb. (kN)	Allowable lb. (kN)
#4 (12.7)	5/8	4 1/4 (108)	6 3/8 (162)	17 (432)	16,480 (73.3)	245 (1.1)	4,120 (18.3)	18,320 (81.5)	560 (2.5)	4,580 (20.4)	4,800 (21.4)
		6 (152)	9 (229)	24 (610)	19,360 (86.1)	678 (3.0)	4,840 (21.5)	19,360 (86.1)	—	4,840 (21.5)	
#5 (15.9)	3/4	5 (127)	7 1/2 (191)	20 (508)	24,600 (109.4)	2,598 (11.6)	6,150 (27.4)	26,040 (115.8)	1,740 (7.7)	6,510 (29.0)	7,440 (33.1)
		9 3/8 (238)	14 1/8 (359)	37 1/2 (953)	48,380 (215.2)	2,841 (12.6)	12,095 (53.8)	48,380 (215.2)	—	12,095 (53.8)	
#6 (19.1)	7/8	6 3/4 (171)	10 1/8 (257)	27 (686)	38,380 (170.7)	4,044 (18.0)	9,595 (42.7)	40,500 (180.2)	1,533 (6.8)	10,125 (45.0)	10,560 (47.0)
		11 1/4 (286)	16 7/8 (429)	45 (1,143)	65,020 (289.2)	3,152 (14.0)	16,255 (72.3)	65,020 (289.2)	—	16,255 (72.3)	
#7 (22.2)	1	7 3/4 (197)	11 5/8 (295)	31 (787)	47,760 (212.4)	1,266 (5.6)	11,940 (53.1)	47,760 (212.4)	—	11,940 (53.1)	14,400 (64.1)
		13 1/8 (333)	19 5/8 (498)	52 1/2 (1,334)	81,560 (362.8)	3,575 (15.9)	20,390 (90.7)	81,560 (362.8)	—	20,390 (90.7)	
#8 (25.4)	1 1/8	9 (229)	13 1/2 (343)	36 (914)	53,680 (238.8)	—	13,420 (59.7)	53,680 (238.8)	—	13,420 (59.7)	18,960 (84.3)
		15 (381)	22 1/2 (572)	60 (1,524)	94,240 (419.2)	7,520 (33.5)	23,560 (104.8)	94,240 (419.2)	—	23,560 (104.8)	
#9 (28.6)	1 1/4	10 1/8 (257)	15 1/4 (387)	40 1/2 (1,029)	53,680 (238.8)	7,977 (35.5)	13,420 (59.7)	53,680 (238.8)	—	13,420 (59.7)	24,000 (106.8)
		16 7/8 (429)	25 3/8 (645)	67 1/2 (1,715)	111,460 (495.8)	5,753 (25.6)	27,865 (123.9)	111,460 (495.8)	—	27,865 (123.9)	
#10 (31.8)	1 1/2	11 1/4 (286)	16 7/8 (429)	45 (1,143)	76,000 (338.1)	1,408 (6.3)	19,000 (84.5)	76,000 (338.1)	—	19,000 (84.5)	30,480 (135.6)
		18 3/4 (476)	28 (711)	75 (1,905)	125,840 (559.8)	9,551 (42.5)	31,460 (139.9)	125,840 (559.8)	—	31,460 (139.9)	
#11 (34.9)	1 5/8	12 3/8 (314)	18 5/8 (473)	49 1/2 (1,257)	87,500 (389.2)	3,498 (15.6)	21,875 (97.3)	87,500 (389.2)	—	21,875 (97.3)	37,440 (166.5)
		20 3/8 (524)	28 (711)	82 1/2 (2,096)	132,080 (587.5)	11,297 (50.3)	33,020 (146.9)	132,080 (587.5)	—	33,020 (146.9)	

1. Allowable load must be the lesser of the bond or steel strength.
2. The allowable loads listed under allowable bond are based on a safety factor of 4.0.
3. Refer to allowable load-adjustment factors for spacing and edge distance on pages 116 and 118.
4. Refer to in-service temperature sensitivity chart for allowable load adjustment for temperature.
5. Anchors are permitted to be used within fire-resistive construction, provided the anchors resist wind or seismic loads only. For use in fire-resistive construction, the anchors can also be permitted to be used to resist gravity loads, provided special consideration has been given to fire-exposure conditions.
6. Anchors are not permitted to resist tension forces in overhead or wall installations unless proper consideration is given to fire exposure and elevated-temperature conditions.
7. Allowable load based on bond strength may be interpolated for concrete compressive strengths between 2,000 psi and 4,000 psi.

* See page 12 for an explanation of the load table icons.

SET Design Information — Concrete

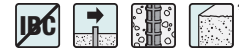

SET Allowable Shear Loads for Rebar Dowels in Normal-Weight Concrete

Rebar Size No. (mm)	Drill Bit Dia. in.	Embed. Depth in. (mm)	Critical Edge Dist. in. (mm)	Critical Spacing Dist. in. (mm)	Shear Load Based on Concrete Edge Distance			Shear Load Based on Steel Strength
					$f'_c \geq 2,000$ psi (13.8 MPa) Concrete			ASTM A615 Grade 60 Rebar
					Ultimate lb. (kN)	Std. Dev. lb. (kN)	Allow. lb. (kN)	Allowable lb. (kN)
#4 (12.7)	5/8	4 1/4 (108)	6 3/8 (162)	6 3/8 (162)	15,156 (67.4)	542 (2.4)	3,790 (16.9)	3,060 (13.6)
		6 (152)			15,156 (67.4)	—	3,790 (16.9)	
#5 (15.9)	3/4	5 (127)	7 1/2 (191)	7 1/2 (191)	24,245 (107.8)	1,121 (5.0)	6,060 (27.0)	4,740 (21.1)
		9 3/8 (238)			24,245 (107.8)	—	6,060 (27.0)	
#6 (19.1)	7/8	6 3/4 (171)	10 1/8 (257)	10 1/8 (257)	33,195 (147.7)	2,314 (10.3)	8,300 (36.9)	6,730 (29.9)
		11 1/4 (286)			33,195 (147.7)	—	8,300 (36.9)	
#7 (22.2)	1	7 3/4 (197)	11 5/8 (295)	11 5/8 (295)	47,017 (209.1)	2,227 (9.9)	11,755 (52.3)	9,180 (40.8)
		13 1/8 (333)			47,017 (209.1)	—	11,755 (52.3)	
#8 (25.4)	1 1/8	9 (229)	13 1/2 (343)	13 1/2 (343)	58,880 (261.9)	—	14,720 (65.5)	12,085 (53.8)
		15 (381)			58,880 (261.9)	—	14,720 (65.5)	
#9 (28.6)	1 1/4	10 1/8 (257)	15 1/4 (387)	15 1/4 (387)	58,880 (261.9)	1,487 (6.6)	14,720 (65.5)	15,300 (68.1)
		16 7/8 (429)			58,880 (261.9)	—	14,720 (65.5)	
#10 (31.8)	1 1/2	11 1/4 (286)	16 7/8 (429)	16 7/8 (429)	65,840 (292.9)	7,120 (31.7)	16,460 (73.2)	19,430 (86.4)
		18 3/4 (476)			65,840 (292.9)	—	16,460 (73.2)	
#11 (34.9)	1 5/8	12 3/8 (314)	18 5/8 (473)	18 5/8 (473)	81,400 (362.1)	9,596 (42.7)	20,350 (90.5)	23,870 (106.2)
		20 5/8 (524)			81,400 (362.1)	—	20,350 (90.5)	

1. Allowable load must be the lesser of the load based on concrete edge distance or steel strength.
2. The allowable loads based on concrete edge distance are based on a safety factor of 4.0.
3. Refer to allowable load-adjustment factors for spacing and edge distance on pages 117 and 119.
4. Refer to in-service temperature Sensitivity chart for allowable load adjustment for temperature.
5. Anchors are permitted to be used within fire-resistive construction, provided the anchors resist wind or seismic loads only. For use in fire-resistive construction, the anchors can also be permitted to be used to resist gravity loads, provided special consideration has been given to fire-exposure conditions.

SET Design Information — Concrete

Adhesive Anchors

SET Allowable Tension Loads for Threaded Rod Anchors in Sand-Lightweight Concrete

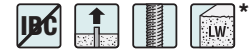

Rod Dia. in. (mm)	Drill Bit Dia. in.	Embed. Depth in. (mm)	Critical Edge Dist. in. (mm)	Critical Spacing Dist. in. (mm)	Tension Load Based on Bond Strength			Tension Load Based on Steel Strength		
					$f'_c \geq 3,000$ psi (20.7 MPa) Lightweight Concrete			F1554 Grade 36	A193 GR B7	F593 304SS
					Ultimate lb. (kN)	Std. Dev. lb. (kN)	Allowable lb. (kN)	Allowable lb. (kN)	Allowable lb. (kN)	Allowable lb. (kN)
3/8 (9.5)	1/2	1 3/4 (44)	2 5/8 (67)	3 1/2 (89)	2,400 (10.7)	540 (2.4)	600 (2.7)	2,105 (9.4)	4,535 (20.2)	3,630 (16.1)
		3 1/2 (89)	5 1/4 (133)	7 (178)	6,220 (27.7)	422 (1.9)	1,555 (6.9)			
1/2 (12.7)	5/8	2 1/8 (54)	3 1/8 (79)	4 1/4 (108)	2,900 (12.9)	550 (2.4)	725 (3.2)	3,750 (16.7)	8,080 (35.9)	6,470 (28.8)
		4 1/4 (108)	6 3/8 (162)	8 1/2 (216)	6,720 (29.9)	1,087 (4.8)	1,680 (7.5)			
5/8 (15.9)	3/4	2 1/2 (64)	3 3/4 (95)	5 (127)	4,820 (21.4)	327 (1.5)	1,205 (5.4)	5,875 (26.1)	12,660 (56.3)	10,120 (45.0)
		5 (127)	7 1/2 (191)	10 (254)	9,160 (40.7)	1,677 (7.5)	2,290 (10.2)			

1. Allowable load must be the lesser of the bond or steel strength.
2. The allowable loads listed under allowable bond are based on a safety factor of 4.0.
3. 100% of the allowable load is permitted at critical spacing. No reduction in spacing is allowed.
4. Refer to allowable load-adjustment factors for edge distance on page 120.
5. Refer to in-service temperature sensitivity chart for allowable load adjustment for temperature.
6. Anchors are permitted to be used within fire-resistive construction, provided the anchors resist wind or seismic loads only. For use in fire-resistive construction, the anchors can also be permitted to be used to resist gravity loads, provided special consideration has been given to fire-exposure conditions.
7. Anchors are not permitted to resist tension forces in overhead or wall installations unless proper consideration is given to fire-exposure and elevated-temperature conditions.

SET Allowable Shear Loads for Threaded Rod Anchors in Sand-Lightweight Concrete

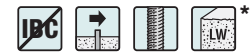

Rod Dia. in. (mm)	Drill Bit Dia. in.	Embed. Depth in. (mm)	Critical Edge Dist. in. (mm)	Critical Spacing Dist. in. (mm)	Shear Load Based on Concrete Edge Distance			Shear Load Based on Steel Strength		
					$f'_c \geq 3,000$ psi (20.7 MPa) Lightweight Concrete			F1554 Grade 36	A193 GR B7	F593 304SS
					Ultimate lb. (kN)	Std. Dev. lb. (kN)	Allowable lb. (kN)	Allowable lb. (kN)	Allowable lb. (kN)	Allowable lb. (kN)
3/8 (9.5)	1/2	1 3/4 (44)	2 5/8 (67)	3 1/2 (89)	2,364 (10.5)	129 (0.6)	590 (2.6)	1,085 (4.8)	2,340 (10.4)	1,870 (8.3)
		3 1/2 (89)	5 1/4 (133)	7 (178)	5,784 (25.7)	547 (2.4)	1,445 (6.4)			
1/2 (12.7)	5/8	2 1/8 (54)	3 1/8 (79)	4 1/4 (108)	2,948 (13.1)	224 (1.0)	735 (3.3)	1,930 (8.6)	4,160 (18.5)	3,330 (14.8)
		4 1/4 (108)	6 3/8 (162)	8 1/2 (216)	8,436 (37.5)	891 (4.0)	2,110 (9.4)			
5/8 (15.9)	3/4	2 1/2 (64)	3 3/4 (95)	5 (127)	3,584 (15.9)	1,072 (4.8)	895 (4.0)	3,025 (13.5)	6,520 (29.0)	5,220 (23.2)
		5 (127)	7 1/2 (191)	10 (254)	11,784 (52.4)	650 (2.9)	2,945 (13.1)			

1. Allowable load must be the lesser of the load based on concrete edge distance or steel strength.
2. The allowable loads based on concrete edge distance are based on a safety factor of 4.0.
3. 100% of the allowable load is permitted at critical spacing. No reduction in spacing is allowed.
4. Refer to allowable load-adjustment factors for edge distance on page 120.
5. Refer to in-service temperature sensitivity chart for allowable load adjustment for temperature.
6. Anchors are permitted to be used within fire-resistive construction, provided the anchors resist wind or seismic loads only. For use in fire-resistive construction, the anchors can also be permitted to be used to resist gravity loads, provided special consideration has been given to fire-exposure conditions.

* See page 12 for an explanation of the load table icons.

SET Design Information — Masonry

SET Allowable Tension and Shear Loads for Threaded Rod Anchors in 8-inch Lightweight, Medium-Weight and Normal-Weight Grout-Filled CMU     *

Rod Dia. in. (mm)	Drill Bit Dia. in.	Min. Embed. Depth in. (mm)	Critical Edge Dist. in. (mm)	Critical End Dist. in. (mm)	Critical Spacing Dist. in. (mm)	8-inch Grout-Filled CMU Allowable Loads Based on CMU Strength			
						Tension		Shear	
						Ultimate lb. (kN)	Allowable lb. (kN)	Ultimate lb. (kN)	Allowable lb. (kN)
Anchor Installed Anywhere on the Face of the CMU Wall (See Figure 1)									
½ (12.7)	5/8	4¼ (108)	17 (432)	17 (432)	17 (432)	6,496 (28.9)	1,300 (5.8)	6,766 (30.1)	1,355 (6.0)
5/8 (15.9)	¾	5 (127)	20 (508)	20 (508)	20 (508)	8,232 (36.6)	1,645 (7.3)	13,676 (60.8)	2,735 (12.2)
¾ (19.1)	7/8	6¾ (171)	27 (686)	27 (686)	27 (686)	15,656 (69.6)	3,130 (13.9)	17,578 (78.2)	3,515 (15.6)

1. Threaded rods must comply with ASTM F1554 Grade 36 minimum.
2. Values for 8-inch wide concrete masonry units (CMU) with a minimum specified compressive strength of masonry, f'_m , at 28 days is 1500 psi.
3. Embedment depth is measured from the outside face of the concrete masonry unit.
4. Allowable loads may be increased 33⅓% for short-term loading due to wind forces or seismic forces where permitted by code.
5. Refer to in-service temperature sensitivity chart for allowable load adjustment for temperature.
6. The tabulated allowable loads are based on a safety factor of 5.0.
7. Refer to allowable load-adjustment factors for end distance, edge distance and spacing on page 121.

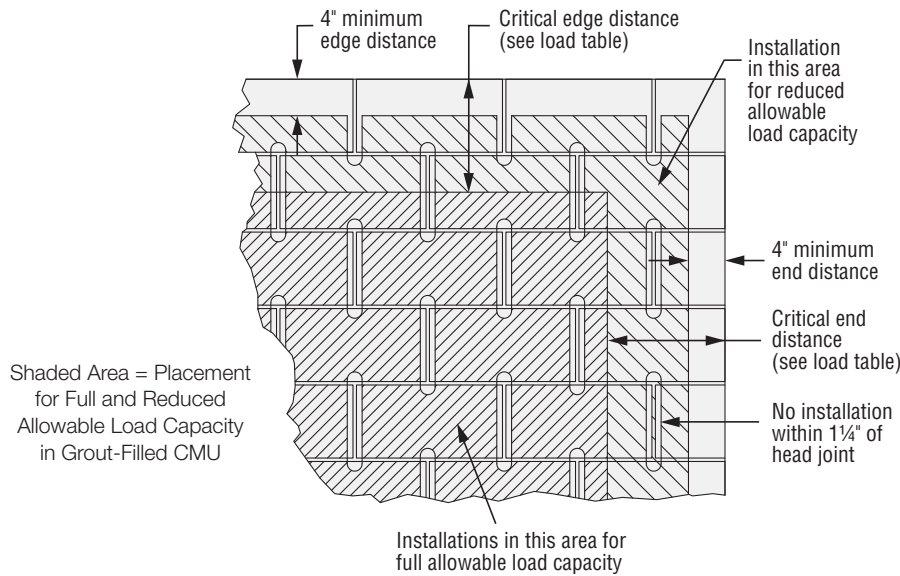

Figure 1

* See page 12 for an explanation of the load table icons.

SET Design Information — Masonry

SET Allowable Tension and Shear Loads for Threaded Rod Anchors in 6- and 8-inch Lightweight, Medium-Weight and Normal-Weight Grout-Filled CMU — Anchor Installed in Cell Opening (Top of Wall)



Adhesive Anchors

Rod Dia. in. (mm)	Drill Bit Dia. in.	Embed. Depth in. (mm)	Min. Edge Dist. in. (mm)	Min. End Dist. in. (mm)	Min. Spacing Dist. in. (mm)	6- and 8-inch Grout-Filled CMU Allowable Loads Based on CMU Strength			
						Tension		Shear	
						Ultimate lb. (kN)	Allowable lb. (kN)	Ultimate lb. (kN)	Allowable lb. (kN)
Allowable Tension and Shear Values EXCLUDING Earthquake Loads¹									
5/8 (15.9)	3/4	5 (127)	3 (76)	3 1/2 (89)	20 (508)	12,573 (55.9)	2,515 (11.2)	9,530 (42.4)	1,905 (8.5)
3/4 (19.1)	7/8	5 (127)	3 (76)	3 1/2 (89)	20 (508)	—	2,515 (11.2)	—	1,905 (8.5)
7/8 (22.2)	1	12 (305)	2 (51)	3 7/8 (98)	48 (1219)	8,908 (39.6)	1,780 (7.9)	—	—
Allowable Tension and Shear Values INCLUDING Earthquake Loads²									
5/8 (15.9)	3/4	5 (127)	3 (76)	3 1/2 (89)	20 (508)	6,500 (28.9)	1,300 (5.8)	6,780 (30.2)	1,355 (6.0)
3/4 (19.1)	7/8	5 (127)	3 (76)	3 1/2 (89)	20 (508)	—	1,300 (5.8)	—	1,355 (6.0)

1. Allowable tension and shear values EXCLUDING earthquake loads may not be increased for wind forces.
2. Allowable tension and shear values INCLUDING earthquake loads may be increased 33 1/3% for wind forces or seismic forces where permitted by code.
3. Also see notes 1–3 and 5–7 on next page.

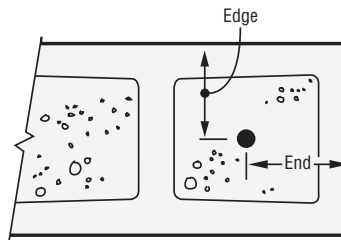

Figure 2
Anchor installed in cell opening (top of wall)

* See page 12 for an explanation of the load table icons.

SET Design Information — Masonry

SET Allowable Tension and Shear Loads for Threaded Rod Anchors in Lightweight, Medium-Weight and Normal-Weight Hollow CMU



Rod Dia. in. (mm)	Drill Bit Dia. in.	Embed. Depth in. (mm)	Min. Edge Dist. in. (mm)	Min. End Dist. in. (mm)	6- and 8-inch Hollow CMU Allowable Loads Based on CMU Strength			
					Tension		Shear	
					Ultimate lb. (kN)	Allowable lb. (kN)	Ultimate lb. (kN)	Allowable lb. (kN)
Anchor Installed in Face Shell with Simpson Strong-Tie® Epoxy Carbon-Steel Screen Tube								
5/8 (15.9)	7/8	3 1/2 (88.9)	4 (101.6)	4 5/8 (117.5)	881 (3.9)	175 (0.8)	1,440 (6.4)	290 (1.3)
3/4 (19.1)	1	3 1/2 (88.9)	4 (101.6)	4 5/8 (117.5)	—	175 (0.8)	—	290 (1.3)

1. Threaded rods must comply with ASTM F1554 Grade 36 minimum.
2. Values for 8-inch wide concrete masonry units (CMU) with a minimum specified compressive strength of masonry, f'm, at 28 days is 1500 psi.
3. Embedment depth is measured from the outside face of the concrete masonry unit for installations through a face shell.
4. Allowable loads may not be increased for short-term loading due to wind forces or seismic forces.
5. Refer to in-service temperature sensitivity chart for allowable load adjustment for temperature.
6. The tabulated allowable loads are based on a safety factor of 5.0.
7. Anchors must be spaced a minimum distance of four times the anchor embedment.
8. Screen tubes not for use with SET1.7KTA.
9. Set drill to rotation-only mode when drilling into hollow CMU.

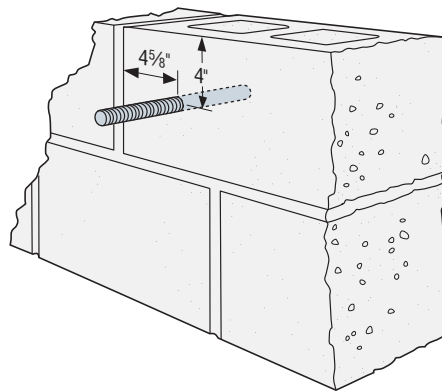
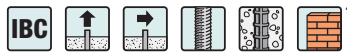

Figure 3
Anchor installed in face shell
with screen tube in hollow cell

* See page 12 for an explanation of the load table icons.

SET Design Information — Masonry

SET Allowable Tension and Shear Loads for Installations in Unreinforced Brick Masonry Walls — Minimum URM Wall Thickness is 13" (3 wythes thick)



Rod/Rebar Dia./Size in. (mm)	Drill Bit Dia. in.	Embed. Depth in. (mm)	Min. Edge/End Dist. in. (mm)	Min. Vertical Spacing Dist. in. (mm)	Min. Horiz. Spacing Dist. in. (mm)	Tension Load Based on URM Strength Allowable lb. (kN)	Shear Load Based on URM Strength Allowable lb. (kN)
Configuration A (Simpson Strong-Tie® ETS or ETSP Screen Tube Required)							
3/4 (19.1)	1	8 (203)	16 (406)	16 (406)	16 (406)	—	1,000 (4.4)
#5 (15.9)	1	8 (203)	16 (406)	16 (406)	16 (406)	—	750 (3.3)
#6 (19.1)	1	8 (203)	16 (406)	16 (406)	16 (406)	—	1,000 (4.4)
Configuration B (Simpson Strong-Tie ETS or ETSP Screen Tube Required)							
3/4 (19.1)	1	13 (330)	16 (406)	16 (406)	16 (406)	1,200 (5.3)	1,000 (4.4)
Configuration C (Simpson Strong-Tie ETS Screen Tube and AST Steel Sleeve Required)							
5/8 (15.9)	1	**	16 (406)	16 (406)	16 (406)	1,200 (5.3)	750 (3.3)

1. Threaded rods must comply with ASTM F1554 Grade 36 minimum.
2. All holes are drilled with a 1" diameter carbide-tipped drill bit with the drill set in the rotation-only mode.
3. The unreinforced brick walls must have a minimum thickness of 13 inches (three wythes of brick).
4. The allowable load is applicable only where in-place shear tests indicate minimum net mortar strength of 50 psi. For installations using a wet diamond core-drill bit, the allowable load is applicable only where in-place shear tests indicate minimum net mortar strength of 325 psi.
5. The allowable load for Configuration B and C anchors subjected to a combined tension and shear load is determined by assuming a straight-line relationship between allowable tension and shear.
6. The anchors installed in unreinforced brick walls are limited to resisting seismic or wind forces only.
7. Configuration A has a straight threaded rod or rebar embedded 8 inches into the wall with a 3/2" diameter by 8-inch long screen tube (part # ETS758 or ETS758P). This configuration is designed to resist shear loads only.
8. Configuration B has a 3/4" threaded rod bent and installed at a 22.5-degree angle and installed 13 inches into the wall, to within 1-inch (maximum) of the exterior wall surface. This configuration is designed to resist tension and shear loads. The pre-bent threaded rod is installed with a 3/2" diameter by 13-inch long screen tube (part # ETS7513 or ETS7513P).
9. Configuration C is designed to resist tension and shear forces. It consists of a 5/8" diameter, ASTM F1554 Grade 36 threaded rod and an 8" long sleeve (part # AST800) and a 3/2" diameter by 8-inch long screen tube (part # ETS758). The steel sleeve has a plastic plug in one end. A 6" by 6" by 3/8" thick ASTM A 36 steel plate is located on the back face of the wall.
10. Special inspection requirements are determined by local jurisdiction and must be confirmed by the local building official.
11. Refer to in-service temperature sensitivity chart for allowable load adjustment for temperature.
12. Screen tubes not for use with SET1.7KTA.

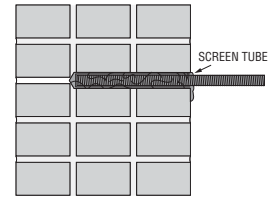

Configuration A (Shear)

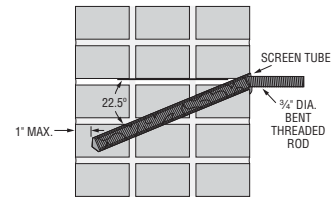

Configuration B (Tension & Shear)

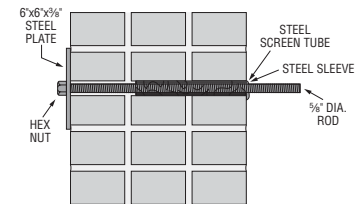

Configuration C (Tension & Shear)

SET Allowable Tension and Shear Loads for Threaded Rod Anchors in Lightweight, Medium-Weight and Normal-Weight Hollow CMU



Rod Dia. in. (mm)	Drill Bit Dia. in.	Embed. Depth in. (mm)	Critical Edge Dist. in. (mm)	Critical Spacing Dist. in. (mm)	8-inch Hollow CMU Allowable Loads Based on CMU Strength			
					Tension		Shear	
					Ultimate lb. (kN)	Allowable lb. (kN)	Ultimate lb. (kN)	Allowable lb. (kN)
Anchor Installed in Face Shell with Simpson Strong-Tie ETSP (Plastic) Screen Tube								
3/8 (9.5)	5/16	3 1/2 (88.9)	12 (305)	8 (203)	1,500 (6.7)	300 (1.3)	1,280 (5.7)	255 (1.1)
1/2 (12.7)	3/4	3 1/2 (88.9)	12 (305)	8 (203)	1,500 (6.7)	300 (1.3)	1,280 (5.7)	255 (1.1)
5/8 (15.9)	7/8	3 1/2 (88.9)	12 (305)	8 (203)	1,500 (6.7)	300 (1.3)	1,380 (6.1)	275 (1.2)

1. Threaded rods must comply with ASTM F1554 Grade 36 minimum.
2. The tabulated allowable loads are based on a safety factor of 5.0
3. Edge distances may be reduced to 4" with a corresponding 32% reduction in tension capacity. Shear capacity is unaffected.
4. Values for 8-inch wide, lightweight, medium-weight and normal-weight concrete masonry units with min. compressive strength of 1,900 psi and 1 1/4" thick face shell.
5. Embedment depth is measured from the outside face of the concrete masonry unit.
6. Refer to in-service temperature sensitivity chart for allowable load adjustment for temperature.
7. Allowable loads may not be increased for short-term loading due to wind or seismic forces. Wall design must satisfy applicable design standards and be capable of withstanding applied loads.
8. Screen tubes not for use with SET1.7KTA.
9. Set drill to rotation-only mode when drilling into hollow CMU.

Installation Instructions for Configuration C

1. Drill hole perpendicular to the wall to a depth of 8" with a 1" diameter carbide-tipped drill bit (rotation only mode).
2. Clean hole with oil-free compressed air and a nylon brush.
3. Fill 8" steel screen tube with mixed adhesive and insert into hole.
4. Insert steel sleeve slowly into screen tube (adhesive will displace).
5. Allow adhesive to cure (see cure schedule).
6. Drill through plastic plug in (inside) end of steel sleeve with 5/8" bit.
7. Drill completely through the wall with 5/8" carbide tipped concrete drill bit (rotation mode only).
8. Insert 5/8" rod through hole and attach metal plate and nut.

* See page 12 for an explanation of the load table icons.

SET Design Information — Masonry

SET Allowable Tension Loads for Threaded Rod Anchors in 8" Lightweight, Medium-Weight and Normal-Weight CMU Chair Blocks Filled with Normal-Weight Concrete

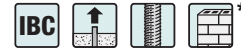

Rod Dia. in. (mm)	Drill Bit Dia. in.	Min. Embed. Depth in. (mm)	Min. Edge Dist. in. (mm)	Critical Spacing Dist. in. (mm)	8-inch Concrete-Filled CMU Chair Block	
					Allowable Tension Loads Based on CMU Strength	
					Ultimate lb. (kN)	Allowable lb. (kN)
1/2 (12.7)	5/8	4 1/2 (114)	1 3/4 (44.5)	18 (457)	4,810 (21.4)	960 (4.3)
		7 (178)	1 3/4 (44.5)	28 (711)	7,715 (34.3)	1,545 (6.9)
5/8 (15.9)	3/4	4 1/2 (114)	1 3/4 (44.5)	18 (457)	4,955 (22.0)	990 (4.4)
		7 (178)	1 3/4 (44.5)	28 (711)	7,600 (33.8)	1,520 (6.8)
		12 (305)	1 3/4 (44.5)	48 (1,219)	12,200 (54.4)	2,440 (10.9)

1. Threaded rods must comply with ASTM F1554 Grade 36 minimum.
2. Values are for 8-inch-wide concrete masonry units CMU filled with concrete with minimum compressive strength of 2,500 psi and poured monolithically with the floor slab.
3. Center #5 rebar in CMU cell and concrete slab as shown.
4. The tabulated allowable loads are based on a safety factor of 5.0.

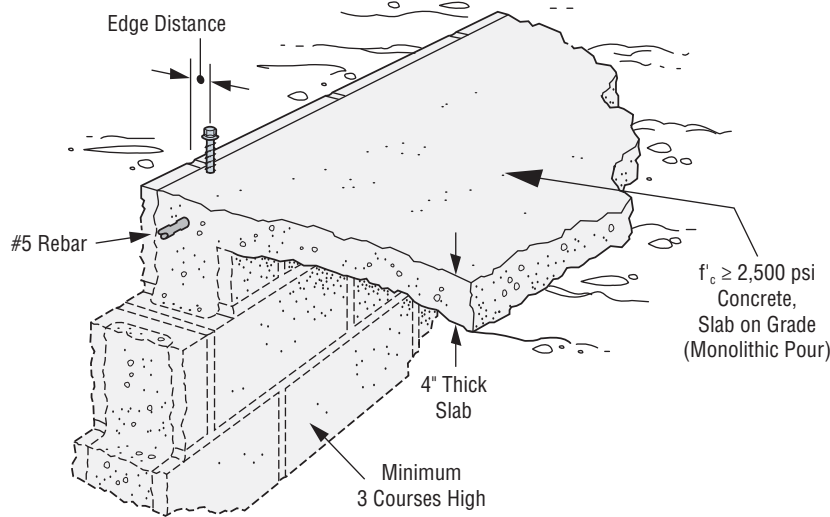

* See page 12 for an explanation of the load table icons.

SET Design Information — Concrete

SET Allowable Load-Adjustment Factors in Normal-Weight Concrete: Edge Distance, Tension Load

How to use these charts

1. The following tables are for reduced edge distance.
2. Locate the anchor size to be used for either a tension and/or shear load application.
3. Locate the embedment (E) at which the anchor is to be installed.
4. Locate the edge distance (c_{act}) at which the anchor is to be installed.
5. The load-adjustment factor (f_c) is the intersection of the row and column.
6. Multiply the allowable load by the applicable load-adjustment factor.
7. Reduction factors for multiple edges are multiplied together.
8. Adjustment factors do not apply to allowable steel strength values.
9. Adjustment factors are to be applied to allowable tension load based on bond strength values only.

Adhesive Anchors

Edge Distance Tension (f_c)

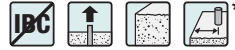

Edge Dist. c_{act} (in.)	Dia.	3/8			1/2			5/8			3/4		
	Rebar	#3			#4			#5			#6		
E	1 3/4	3 1/2	4 1/2	2 1/8	4 1/4	6	2 1/2	5	9 3/8	3 3/8	6 3/4	11 1/4	
c_{cr}	2 5/8	5 1/4	6 3/4	3 1/4	6 3/8	9	3 3/4	7 1/2	14 1/8	5 1/8	10 1/8	16 7/8	
c_{min}	1 3/4	1 3/4	1 3/4	1 3/4	1 3/4	1 3/4	1 3/4	1 3/4	1 3/4	1 3/4	1 3/4	1 3/4	
f_{cmin}	0.65	0.65	0.69	0.65	0.65	0.59	0.48	0.48	0.64	0.48	0.48	0.57	
1 3/4		0.65	0.65	0.69	0.65	0.65	0.59	0.48	0.48	0.64	0.48	0.48	0.57
2		0.75	0.68	0.71	0.71	0.67	0.60	0.55	0.50	0.65	0.52	0.50	0.58
3		1.00	0.78	0.77	0.95	0.74	0.66	0.81	0.59	0.68	0.68	0.56	0.61
4			0.88	0.83	1.00	0.82	0.72	1.00	0.68	0.71	0.83	0.62	0.63
5			0.98	0.89		0.90	0.77		0.77	0.73	0.99	0.68	0.66
6			1.00	0.95		0.97	0.83		0.86	0.76	1.00	0.74	0.69
7				1.00		1.00	0.89		0.95	0.79		0.81	0.72
8							0.94		1.00	0.82		0.87	0.75
9							1.00			0.85		0.93	0.78
10										0.88		0.99	0.80
11										0.91		1.00	0.83
12										0.94			0.86
14										1.00			0.92
16													0.98
17													1.00

See notes below.

Edge Distance Tension (f_c) (continued)



Edge Dist. c_{act} (in.)	Dia.	7/8			1		1 1/8			1 1/4				
	Rebar	#7			#8		#9			#10			#11	
E	3 7/8	7 3/4	13 1/8	4 1/2	9	15	5 1/8	10 1/8	16 7/8	5 3/8	11 1/4	18 3/4	12 3/8	20 5/8
c_{cr}	5 7/8	11 5/8	19 5/8	6 3/4	13 1/2	22 1/2	7 3/4	15 1/4	25 3/8	8 1/2	16 7/8	28 1/8	28 1/8	28 1/8
c_{min}	1 3/4	1 3/4	1 3/4	1 3/4	1 3/4	1 3/4	2 3/4	2 3/4	2 3/4	2 3/4	2 3/4	2 3/4	2 3/4	2 3/4
f_{cmin}	0.48	0.48	0.52	0.48	0.48	0.47	0.58	0.58	0.51	0.58	0.58	0.51	0.58	0.51
1 3/4		0.48	0.48	0.52	0.48	0.47								
2 3/4		0.61	0.53	0.55	0.58	0.52	0.50	0.58	0.58	0.51	0.58	0.58	0.51	0.58
4		0.77	0.60	0.58	0.71	0.58	0.53	0.69	0.62	0.54	0.67	0.62	0.53	0.61
6		1.00	0.70	0.63	0.92	0.67	0.58	0.85	0.69	0.58	0.82	0.68	0.57	0.67
8			0.81	0.69	1.00	0.76	0.63	1.00	0.76	0.62	0.97	0.74	0.61	0.72
10			0.91	0.74		0.85	0.68		0.82	0.67	1.00	0.80	0.65	0.77
12			1.00	0.80		0.93	0.73		0.89	0.71		0.86	0.69	0.82
14				0.85		1.00	0.78		0.96	0.75		0.91	0.73	0.88
16				0.90			0.83		1.00	0.80		0.97	0.77	0.93
18				0.96			0.89			0.84		1.00	0.80	0.98
20				1.00			0.94			0.88			0.84	1.00
24							1.00			0.97			0.92	0.92
28										1.00			1.00	1.00

* See page 12 for an explanation of the load table icons.

SET Design Information — Concrete

SET Allowable Load-Adjustment Factors in Normal-Weight Concrete: Edge Distance, Shear Load

How to use these charts

- The following tables are for reduced edge distance.
- Locate the anchor size to be used for either a tension and/or shear load application.
- Locate the embedment (E) at which the anchor is to be installed.
- Locate the edge distance (c_{act}) at which the anchor is to be installed.
- The load-adjustment factor (f_c) is the intersection of the row and column.
- Multiply the allowable load by the applicable load-adjustment factor.
- Reduction factors for multiple edges are multiplied together.
- Adjustment factors do not apply to allowable steel strength values.
- Adjustment factors are to be applied to allowable shear load based on concrete edge distance values only.

Edge Distance Shear (f_c)

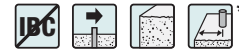

Edge Dist. c_{act} (in.)	Dia. Rebar	3/8		1/2		1/2		5/8		5/8		3/4		3/4		
						#4				#5				#6		
	E	1 3/4	3 1/2	4 1/2	2 1/8	4 1/4	4 1/4	6	2 1/2	5	5	9 3/8	3 3/8	6 3/4	6 3/4	11 1/4
	c_{cr}	5 1/4	5 1/4	5 1/4	6 3/8	6 3/8	6 3/8	6 3/8	7 1/2	7 1/2	7 1/2	7 1/2	10 1/8	10 1/8	10 1/8	10 1/8
c_{min}	1 3/4	1 3/4	1 3/4	1 3/4	1 3/4	1 3/4	1 3/4	1 3/4	1 3/4	1 3/4	1 3/4	1 3/4	1 3/4	1 3/4	1 3/4	
f_{cmin}	0.49	0.32	0.35	0.37	0.20	0.25	0.24	0.18	0.15	0.21	0.19	0.16	0.16	0.18	0.15	
1 3/4		0.49	0.32	0.35	0.37	0.20	0.25	0.24	0.18	0.15	0.21	0.19	0.16	0.16	0.18	0.15
2		0.53	0.37	0.40	0.40	0.24	0.29	0.28	0.22	0.19	0.24	0.23	0.19	0.19	0.20	0.18
3		0.67	0.56	0.58	0.54	0.42	0.45	0.45	0.36	0.33	0.38	0.37	0.29	0.29	0.30	0.28
4		0.82	0.76	0.77	0.68	0.59	0.61	0.61	0.50	0.48	0.52	0.51	0.39	0.39	0.40	0.38
5		0.96	0.95	0.95	0.81	0.76	0.78	0.77	0.64	0.63	0.66	0.65	0.49	0.49	0.50	0.48
6		1.00	1.00	1.00	0.95	0.94	0.94	0.94	0.79	0.78	0.79	0.79	0.59	0.59	0.60	0.58
7					1.00	1.00	1.00	1.00	0.93	0.93	0.93	0.93	0.69	0.69	0.69	0.68
8									1.00	1.00	1.00	1.00	0.79	0.79	0.79	0.78
9													0.89	0.89	0.89	0.89
10													0.99	0.99	0.99	0.99
11													1.00	1.00	1.00	1.00

See notes below.

Edge Distance Shear (f_c) (continued)



Edge Dist. c_{act} (in.)	Dia. Rebar	7/8		7/8		1		1		1 1/8		1 1/4		1 1/4			
				#7				#8		#9		#10		#11			
	E	3 7/8	7 3/4	7 3/4	13 1/8	4 1/2	9	9	15	5 1/8	10 1/8	16 7/8	5 1/8	11 1/4	18 3/4	12 3/8	20 5/8
	c_{cr}	11 5/8	11 5/8	11 5/8	11 5/8	13 1/2	13 1/2	13 1/2	13 1/2	15 1/4	15 1/4	15 1/4	16 7/8	16 7/8	16 7/8	18 5/8	18 5/8
c_{min}	1 3/4	1 3/4	1 3/4	1 3/4	1 3/4	1 3/4	1 3/4	1 3/4	2 3/4	2 3/4	2 3/4	2 3/4	2 3/4	2 3/4	2 3/4	2 3/4	
f_{cmin}	0.14	0.13	0.14	0.10	0.14	0.10	0.12	0.10	0.17	0.16	0.12	0.17	0.16	0.12	0.16	0.12	
1 3/4		0.14	0.13	0.14	0.10	0.14	0.10	0.12	0.10								
2 3/4		0.23	0.22	0.23	0.19	0.21	0.18	0.19	0.18	0.17	0.16	0.12	0.17	0.16	0.12	0.16	0.12
3		0.25	0.24	0.25	0.21	0.23	0.20	0.21	0.20	0.19	0.18	0.14	0.18	0.17	0.14	0.17	0.13
4		0.34	0.33	0.34	0.31	0.30	0.27	0.29	0.27	0.25	0.24	0.21	0.24	0.23	0.20	0.23	0.19
5		0.42	0.42	0.42	0.40	0.38	0.35	0.36	0.35	0.32	0.31	0.28	0.30	0.29	0.26	0.28	0.24
6		0.51	0.50	0.51	0.49	0.45	0.43	0.44	0.43	0.39	0.38	0.35	0.36	0.35	0.32	0.33	0.30
7		0.60	0.59	0.60	0.58	0.52	0.50	0.51	0.50	0.45	0.45	0.42	0.42	0.41	0.38	0.38	0.36
8		0.68	0.68	0.68	0.67	0.60	0.58	0.59	0.58	0.52	0.51	0.49	0.48	0.47	0.45	0.44	0.41
9		0.77	0.77	0.77	0.76	0.67	0.66	0.66	0.66	0.59	0.58	0.56	0.54	0.53	0.51	0.49	0.47
10		0.86	0.86	0.86	0.85	0.74	0.73	0.74	0.73	0.65	0.65	0.63	0.60	0.59	0.57	0.54	0.52
11		0.95	0.94	0.95	0.94	0.82	0.81	0.81	0.81	0.72	0.71	0.70	0.65	0.65	0.63	0.60	0.58
12		1.00	1.00	1.00	1.00	0.89	0.89	0.89	0.89	0.78	0.78	0.77	0.71	0.71	0.70	0.65	0.63
13						0.96	0.96	0.96	0.96	0.85	0.85	0.84	0.77	0.77	0.76	0.70	0.69
14						1.00	1.00	1.00	1.00	0.92	0.92	0.91	0.83	0.83	0.82	0.76	0.74
15										0.98	0.98	0.98	0.89	0.89	0.88	0.81	0.80
16										1.00	1.00	1.00	0.95	0.95	0.95	0.86	0.85
17													1.00	1.00	1.00	0.91	0.91
18 5/8																1.00	1.00

- E = Embedment depth (inches).
- c_{act} = actual edge distance at which anchor is installed (inches).
- c_{cr} = critical edge distance for 100% load (inches).
- c_{min} = minimum edge distance for reduced load (inches).
- f_c = adjustment factor for allowable load at actual edge distance.
- f_{ccr} = adjustment factor for allowable load at critical edge distance. f_{ccr} is always = 1.00.
- f_{cmin} = adjustment factor for allowable load at minimum edge distance.
- $f_c = f_{cmin} + [(1 - f_{cmin})(c_{act} - c_{min}) / (c_{cr} - c_{min})]$.

* See page 12 for an explanation of the load table icons.

SET Design Information — Concrete

SET Allowable Load-Adjustment Factors in Normal-Weight Concrete: Spacing, Tension Load

How to use these charts

- The following tables are for reduced spacing.
- Locate the anchor size to be used for either a tension and/or shear load application.
- Locate the embedment (E) at which the anchor is to be installed.
- Locate the spacing (s_{act}) at which the anchor is to be installed.
- The load-adjustment factor (f_s) is the intersection of the row and column.
- Multiply the allowable load by the applicable load-adjustment factor.
- Reduction factors for multiple spacings are multiplied together.
- Adjustment factors do not apply to allowable steel strength values.
- Adjustment factors are to be applied to allowable tension load based on bond strength values only.

Adhesive Anchors

Spacing Tension (f_s)

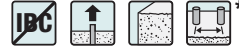

s_{act} (in.)	Dia.	¾			½			⅝			¾		
	Rebar	#4			#4			#5			#6		
	E	1¾	3½	4½	2½	4¼	6	2½	5	9¾	3¾	6¾	11¼
	s_{cr}	7	14	18	8½	17	24	10	20	37½	13½	27	45
s_{min}	⅞	1¾	2¼	1½	2½	3	1¼	2½	4¾	1¾	3¾	5¾	
f_{smin}	0.52	0.89	0.90	0.52	0.89	0.90	0.52	0.89	0.90	0.52	0.89	0.90	
7/8	0.52												
1	0.53												
2	0.61	0.89			0.58			0.56			0.53		
4	0.76	0.91	0.91		0.71	0.90	0.90	0.67	0.90		0.61	0.89	
6	0.92	0.93	0.92		0.84	0.92	0.91	0.78	0.91	0.90	0.69	0.90	0.90
8	1.00	0.95	0.94		0.97	0.93	0.92	0.89	0.92	0.91	0.78	0.91	0.91
10		0.96	0.95		1.00	0.95	0.93	1.00	0.94	0.92	0.86	0.92	0.91
12		0.98	0.96			0.96	0.94		0.95	0.92	0.94	0.93	0.92
14		1.00	0.97			0.98	0.95		0.96	0.93	1.02	0.94	0.92
16			0.99			0.99	0.96		0.97	0.93		0.95	0.93
18			1.00			1.00	0.97		0.99	0.94		0.96	0.93
20							0.98		1.00	0.95		0.97	0.94
24							1.00			0.96		0.99	0.95
28										0.97		1.00	0.96
32										0.98			0.97
36										1.00			0.98
40										1.00			0.99
45													1.00

- E = Embedment depth (inches).
- s_{act} = actual spacing distance at which anchors are installed (inches).
- s_{cr} = critical spacing distance for 100% load (inches).
- s_{min} = minimum spacing distance for reduced load (inches).
- f_s = adjustment factor for allowable load at actual spacing distance.
- $f_{s_{cr}}$ = adjustment factor for allowable load at critical spacing distance. $f_{s_{cr}}$ is always = 1.00.
- $f_{s_{min}}$ = adjustment factor for allowable load at minimum spacing distance.
- $f_s = f_{s_{min}} + [(1 - f_{s_{min}})(s_{act} - s_{min}) / (s_{cr} - s_{min})]$.

Spacing Tension (f_s) (continued)



s_{act} (in.)	Dia.	¾			1			1⅝			1¼				
	Rebar	#7			#8			#9			#10			#11	
	E	3¾	7¾	13¾	4½	9	15	5½	10½	16¾	5½	11¼	18¾	12¾	20¾
	s_{cr}	15½	31	52½	18	36	60	20½	40½	67½	22½	45	75	49½	82½
s_{min}	2	3¾	6¾	2¼	4½	7½	2¾	5½	8½	2¾	5½	9¾	6¼	10¾	
f_{smin}	0.52	0.89	0.90	0.52	0.89	0.90	0.52	0.89	0.90	0.52	0.89	0.90	0.89	0.90	
2	0.52														
3	0.56				0.54			0.53			0.52				
4	0.59	0.89			0.57			0.56			0.55				
5	0.63	0.89			0.60	0.89		0.58			0.57				
6	0.66	0.90			0.63	0.90		0.61	0.89		0.60	0.89			
8	0.73	0.91	0.90		0.70	0.90	0.90	0.66	0.90		0.65	0.90		0.89	
10	0.80	0.91	0.91		0.76	0.91	0.90	0.72	0.91	0.90	0.69	0.90	0.90	0.90	
12	0.88	0.92	0.91		0.82	0.92	0.91	0.77	0.91	0.91	0.74	0.91	0.90	0.90	
14	0.95	0.93	0.92		0.88	0.92	0.91	0.83	0.92	0.91	0.79	0.91	0.91	0.91	
16	1.00	0.94	0.92		0.94	0.92	0.92	0.88	0.92	0.91	0.84	0.92	0.91	0.91	
20		0.96	0.93		1.00	0.94	0.92	0.99	0.94	0.92	0.94	0.93	0.92	0.91	
24		0.97	0.94			0.96	0.93	1.00	0.95	0.93	1.00	0.94	0.92	0.92	
28		0.99	0.95			0.97	0.94		0.96	0.93		0.95	0.93	0.92	
32		1.00	0.96			0.99	0.95		0.97	0.94		0.96	0.93	0.93	
36			0.96			1.00	0.95		0.99	0.95		0.97	0.94	0.94	
40			0.97				0.96		1.00	0.95		0.99	0.95	0.94	
50			0.99				0.98			0.97		1.00	0.96	0.95	
60			1.00				1.00			0.99			0.98	0.97	
70										1.00			0.99	0.98	
75													1.00	0.99	
82½														1.00	

See notes above.

* See page 12 for an explanation of the load table icons.

SET Design Information — Concrete

SET Allowable Load-Adjustment Factors in Normal-Weight Concrete: Spacing, Shear Load

How to use these charts

- The following tables are for reduced spacing.
- Locate the anchor size to be used for either a tension and/or shear load application.
- Locate the embedment (E) at which the anchor is to be installed.
- Locate the spacing (s_{act}) at which the anchor is to be installed.
- The load-adjustment factor (f_s) is the intersection of the row and column.
- Multiply the allowable load by the applicable load-adjustment factor.
- Reduction factors for multiple spacings are multiplied together.
- Adjustment factors do not apply to allowable steel strength values.
- Adjustment factors are to be applied to allowable shear load based on concrete edge distance values only.

Spacing Shear (f_s)

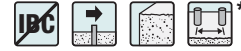

s_{act} (in.)	Dia.	3/8		1/2		5/8		3/4		7/8		1		1 1/8		1 1/4	
	Rebar	#4	#5	#6	#7	#8	#9	#10	#11								
E	1 3/4	3 1/2	2 1/8	4 1/4	2 1/2	5	3 3/8	6 3/4	3 7/8	7 3/4	4 1/2	9	5 1/8	10 1/8	5 5/8	11 1/4	12 3/8
s_{cr}	2 5/8	5 1/4	3 1/4	6 5/8	3 3/4	7 1/2	5 1/8	10 1/8	5 7/8	11 5/8	6 3/4	13 1/2	7 3/4	15 1/4	8 1/2	16 7/8	18 5/8
s_{min}	7/8	1 1/4	1 1/8	2 1/8	1 1/4	2 1/2	1 3/4	3 3/8	2	3 7/8	2 1/4	4 1/2	2 5/8	5 1/8	2 7/8	5 5/8	6 1/4
f_{smin}	0.90	0.83	0.90	0.83	0.90	0.83	0.90	0.83	0.90	0.83	0.90	0.83	0.90	0.83	0.90	0.83	0.83
7/8	0.90																
1	0.91																
1 1/2	0.94		0.92		0.91												
2	0.96	0.84	0.94		0.93		0.91		0.90								
2 1/2	0.99	0.87	0.96	0.85	0.95	0.83	0.92		0.91		0.91						
3	1.00	0.89	0.99	0.87	0.97	0.85	0.94		0.93		0.92		0.91		0.90		
3 1/2		0.92	1.00	0.89	0.99	0.86	0.95	0.83	0.94		0.93		0.92		0.91		
4		0.94		0.91	1.00	0.88	0.97	0.85	0.95	0.83	0.94		0.93		0.92		
5		0.99		0.95		0.92	1.00	0.87	0.98	0.85	0.96	0.84	0.95		0.94		
6		1.00		0.99		0.95		0.90	1.00	0.88	0.98	0.86	0.97	0.84	0.96	0.84	
7				1.00		0.98		0.92		0.90	1.00	0.88	0.99	0.86	0.97	0.85	0.84
8						1.00		0.95		0.92		0.90	1.00	0.88	0.99	0.87	0.85
9								0.97		0.94		0.92		0.90	1.00	0.88	0.87
10								1.00		0.96		0.93		0.91		0.90	0.88
12										1.00		0.97		0.95		0.93	0.91
14												1.00		0.98		0.96	0.94
16														1.00		0.99	0.96
17																1.00	0.98
18 5/8																	1.00

- E = Embedment depth (inches).
- s_{act} = actual spacing distance at which anchors are installed (inches).
- s_{cr} = critical spacing distance for 100% load (inches).
- s_{min} = minimum spacing distance for reduced load (inches).
- f_s = adjustment factor for allowable load at actual spacing distance.
- $f_{s_{cr}}$ = adjustment factor for allowable load at critical spacing distance. $f_{s_{cr}}$ is always = 1.00.
- $f_{s_{min}}$ = adjustment factor for allowable load at minimum spacing distance.
- $f_s = f_{s_{min}} + [(1 - f_{s_{min}}) (s_{act} - s_{min}) / (s_{cr} - s_{min})]$.

* See page 12 for an explanation of the load table icons.

SET Design Information — Concrete

SET Allowable Load-Adjustment Factors in Sand-Lightweight Concrete: Edge Distance, Tension and Shear Loads

How to use these charts

- The following tables are for reduced edge distance only.
- Locate the anchor size to be used for either a tension and/or shear load application.
- Locate the embedment (E) at which the anchor is to be installed.
- Locate the edge distance (c_{act}) at which the anchor is to be installed.
- The load-adjustment factor (f_c) is the intersection of the row and column.
- Multiply the allowable load by the applicable load-adjustment factor.
- Reduction factors for multiple edges are multiplied together.
- Adjustment factors do not apply to allowable steel strength values.
- Adjustment factors are to be applied to allowable tension load based on bond strength values or allowable shear load based on concrete edge distance values only.

Edge Distance Tension (f_c)

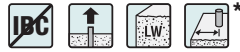

Edge Dist. c_{act} (in.)	Dia.	¾		½		⅝	
	E	1¼	3½	2½	4¼	2½	5
	c_{cr}	2⅝	5¼	3⅞	6⅞	3¾	7½
	c_{min}	1¼	1¼	1¼	1¼	1¼	1¼
	f_{cmin}	0.65	0.65	0.65	0.65	0.48	0.48
1¼		0.65	0.65	0.65	0.65	0.48	0.48
2		0.75	0.68	0.71	0.67	0.55	0.50
2¼		0.85	0.70	0.78	0.69	0.61	0.53
2½		0.95	0.73	0.84	0.71	0.68	0.55
2¾		1.00	0.75	0.90	0.73	0.74	0.57
3			0.78	0.97	0.74	0.81	0.59
3¼			0.80	1.00	0.76	0.87	0.62
3½			0.83		0.78	0.94	0.64
3¾			0.85		0.80	1.00	0.66
4			0.88		0.82		0.68
4¼			0.90		0.84		0.71
4½			0.93		0.86		0.73
4¾			0.95		0.88		0.75
5			0.98		0.90		0.77
5¼			1.00		0.91		0.80
5½					0.93		0.82
5¾					0.95		0.84
6					0.97		0.86
6¼					0.99		0.89
6½					1.00		0.91
6¾							0.93
7							0.95
7¼							0.98
7½							1.00

Edge Distance Shear (f_c)

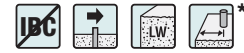

Edge Dist. c_{act} (in.)	Dia.	¾		½		⅝	
	E	1¼	3½	2½	4¼	2½	5
	c_{cr}	2⅝	5¼	3⅞	6⅞	3¾	7½
	c_{min}	1¼	1¼	1¼	1¼	1¼	1¼
	f_{cmin}	0.25	0.25	0.20	0.20	0.15	0.15
1¼		0.25	0.25	0.20	0.20	0.15	0.15
2		0.46	0.30	0.35	0.24	0.26	0.19
2¼		0.68	0.36	0.49	0.29	0.36	0.22
2½		0.89	0.41	0.64	0.33	0.47	0.26
2¾		1.00	0.46	0.78	0.37	0.58	0.30
3			0.52	0.93	0.42	0.68	0.33
3¼			0.57	1.00	0.46	0.79	0.37
3½			0.63		0.50	0.89	0.41
3¾			0.68		0.55	1.00	0.45
4			0.73		0.59		0.48
4¼			0.79		0.63		0.52
4½			0.84		0.68		0.56
4¾			0.89		0.72		0.59
5			0.95		0.76		0.63
5¼			1.00		0.81		0.67
5½					0.85		0.70
5¾					0.89		0.74
6					0.94		0.78
6¼					0.98		0.82
6½					1.00		0.85
6¾							0.89
7							0.93
7¼							0.96
7½							1.00

- E = Embedment depth (inches).
- c_{act} = actual edge distance at which anchor is installed (inches).
- c_{cr} = critical edge distance for 100% load (inches).
- c_{min} = minimum edge distance for reduced load (inches).
- f_c = adjustment factor for allowable load at actual edge distance.
- f_{cr} = adjustment factor for allowable load at critical edge distance. f_{cr} is always = 1.00.
- f_{cmin} = adjustment factor for allowable load at minimum edge distance.
- $f_c = f_{cmin} + [(1 - f_{cmin}) (C_{act} - C_{min}) / (C_{cr} - C_{min})]$.

* See page 12 for an explanation of the load table icons.

SET Design Information — Masonry

SET Allowable Load-Adjustment Factors in Face of Wall Installation in 8" Grout-Filled CMU: End/Edge Distance and Spacing, Tension and Shear Loads

How to use these charts

1. The following tables are for reduced end and edge distance and spacing.
2. Locate the anchor size to be used for either a tension and/or shear load application.
3. Locate the embedment (E) at which the anchor is to be installed.
4. Locate the end or edge distance (C_{act}) or spacing (S_{act}) at which the anchor is to be installed.
5. The load-adjustment factor (f_c or f_s) is the intersection of the row and column.
6. Multiply the allowable load by the applicable load-adjustment factor.
7. Reduction factors for multiple edges or spacing are multiplied together.
8. Adjustment factors do not apply to allowable steel strength values.
9. Adjustment factors are to be applied to allowable tension or shear load based on CMU strength values only.

End Distance Tension (f_c)

C_{act} (in.)	Dia.	1/2	5/8	3/4
	E	4 1/4	5	6 3/4
	C_{cr}	17	20	27
	C_{min}	4	4	4
	f_{cmin}	1.00	0.84	0.54**
4		1.00	0.84	0.54
8		1.00	0.88	0.62
12		1.00	0.92	0.70
16		1.00	0.96	0.78
17		1.00	0.97	0.80
20			1.00	0.86
24				0.94
27				1.00

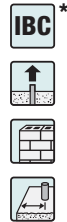

See notes below.

Edge Distance Tension (f_c)

C_{act} (in.)	Dia.	1/2	5/8	3/4
	E	4 1/4	5	6 3/4
	C_{cr}	17	20	27
	C_{min}	4	4	4
	f_{cmin}	1.00	0.84	0.54**
4		1.00	0.84	0.54
8		1.00	0.88	0.62
12		1.00	0.92	0.70
16		1.00	0.96	0.78
17		1.00	0.97	0.80
20			1.00	0.86
24				0.94
27				1.00



** The allowable tension load reduction factor is permitted to equal 1.0 provided both of the following conditions are met: (a) The anchor is installed with a minimum end distance, C_{min} , between 4 inches and 8 inches; and (b) a masonry return wall of identical construction is on the opposite side (such as two masonry walls intersecting at a building corner).

See notes below.

End and Edge Distance Shear (f_c) Shear Load Perpendicular to End or Edge

C_{act} (in.)	Dia.	1/2	5/8	3/4
	E	4 1/4	5	6 3/4
	C_{cr}	17	20	27
	C_{min}	4	4	4
	f_{cmin}	0.43	0.25	0.25
4		0.43	0.25	0.25
8		0.61	0.44	0.38
12		0.78	0.63	0.51
16		0.96	0.81	0.64
17		1.00	0.86	0.67
20			1.00	0.77
24				0.90
27				1.00

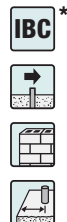

Spacing Tension (f_s)

S_{act} (in.)	Dia.	1/2	5/8	3/4
	E	4 1/4	5	6 3/4
	S_{cr}	17	20	27
	S_{min}	8	8	8
	f_{smin}	0.89	0.81	0.59
8		0.89	0.81	0.59
12		0.94	0.87	0.68
16		0.99	0.94	0.76
17		1.00	0.95	0.78
20			1.00	0.85
24				0.94
27				1.00

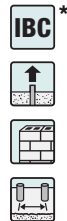

End and Edge Distance Shear (f_c) Shear Load Parallel to End or Edge

C_{act} (in.)	Dia.	1/2	5/8	3/4
	E	4 1/4	5	6 3/4
	C_{cr}	17	20	27
	C_{min}	4	4	4
	f_{cmin}	0.95	0.51	0.45
4		0.95	0.51	0.45
8		0.97	0.63	0.55
12		0.98	0.76	0.64
16		1.00	0.88	0.74
17		1.00	0.91	0.76
20			1.00	0.83
24				0.93
27				1.00



1. E = Embedment depth (inches).
2. C_{act} = actual end or edge distance at which anchor is installed (inches).
3. C_{cr} = critical end or edge distance for 100% load (inches).
4. C_{min} = minimum end or edge distance for reduced load (inches).
5. f_c = adjustment factor for allowable load at actual end or edge distance.
6. f_{ccr} = adjustment factor for allowable load at critical end or edge distance. f_{ccr} is always = 1.00.
7. f_{cmin} = adjustment factor for allowable load at minimum end or edge distance.
8. $f_c = f_{cmin} + [(1 - f_{cmin}) (C_{act} - C_{min}) / (C_{cr} - C_{min})]$.

Spacing Shear (f_s)

S_{act} (in.)	Dia.	1/2	5/8	3/4
	E	4 1/4	5	6 3/4
	S_{cr}	17	20	27
	S_{min}	8	8	8
	f_{smin}	1.00	1.00	1.00
8		1.00 for all spacing \geq 8 in.		
12				
16				
17				
20				
24				
27				



1. E = Embedment depth (inches).
2. S_{act} = actual spacing distance at which anchors are installed (inches).
3. S_{cr} = critical spacing distance for 100% load (inches).
4. S_{min} = minimum spacing distance for reduced load (inches).
5. f_s = adjustment factor for allowable load at actual spacing distance.
6. $f_{s cr}$ = adjustment factor for allowable load at critical spacing distance. $f_{s cr}$ is always = 1.00.
7. $f_{s min}$ = adjustment factor for allowable load at minimum spacing distance.
8. $f_s = f_{s min} + [(1 - f_{s min}) (S_{act} - S_{min}) / (S_{cr} - S_{min})]$.

* See page 12 for an explanation of the load table icons.

EDOT Epoxy Adhesive

Formulated specifically for transportation projects, EDOT adhesive is a two-component, high-solids epoxy system. It is designed for use as a high-strength, non-shrink anchor-grouting material. EDOT adhesive provides an economical solution for transportation applications. Visit www.strongtie.com/DOT for specific state DOT approvals.

Features

- Meets ASTM C881 and AASHTO M-235 specifications for Type I, II, IV and V, Grade 3, Class C
- Cure times – 24 hours at 60°F, 72 hours at 40°F
- Easy hole-cleaning procedure – no power-brushing required
- Suitable for use in damp or wet anchor sites
- When properly mixed, adhesive will be a uniform tan color
- Available in 22 oz. and 56 oz. cartridges for application versatility
- Available in 1-, 10- and 100-gallon bulk kits
- Made in the USA using global materials

Applications

- Threaded rod anchoring and rebar doweling into concrete and masonry
- Multiple DOT listings – refer to www.strongtie.com/DOT for current approvals

Codes: Multiple DOT listings (refer to www.strongtie.com/DOT for current approvals)

Chemical Resistance

See pages 320–321.

Installation and Application Instructions

(See also pages 124–127.)

- Surfaces to receive epoxy must be clean.
- Base material temperature must be 40°F or above at the time of installation. For best results, material should be 70°–80°F at time of application.
- To warm cold material, store cartridges in a warm, uniformly heated area or storage container. Do not immerse cartridges in water to facilitate warming.
- Mixed material in nozzle can harden in 30 minutes at temperatures of 70°F and above.

Suggested Specifications

See www.strongtie.com for more information.



EDOT Adhesive

EDOT Epoxy Adhesive

Test Criteria

Anchors installed with EDOT adhesive have been tested in accordance with ASTM E1512.

Property	Test Method	Result*
Consistency (77°F)	ASTM C881	Non-sag/thixotropic paste
Heat deflection	ASTM D648	127°F (53°C)
Bond strength (moist cure, 60°F) Hardened concrete to hardened concrete	ASTM C882	2,920 psi (2 days) 3,410 psi (14 days)
Bond strength Fresh concrete to hardened concrete	ASTM C882	2,298 psi (14 days)
Water absorption	ASTM D570	0.11% (24 hours)
Compressive yield strength (cured 60°F)	ASTM D695	10,390 psi (7 days)
Compressive modulus (cured 60°F)	ASTM D695	408,100 psi (7 days)
Shore D Hardness	ASTM D2240	83
Gel time	ASTM C881	60 minutes
Shrinkage coefficient	ASTM D2566	0.002 in./in.
VOC	ASTM D2369	6 g/L

*Material and curing conditions: 73 ± 2°F, unless otherwise noted.

EDOT Package Systems

Model No.	Capacity	Cartridge Type	Carton Quantity	Dispensing Tool(s)	Mixing Nozzle
EDOT22	22 ounces	cartridge, side-by-side	10	EDT22S, EDTA22CKT, EDTA22P	EMN22i
EDOT22-N ¹	22 ounces	cartridge, side-by-side	10	EDT22S, EDTA22CKT, EDTA22P	EMN22i
EDOT56	56 ounces	cartridge, side-by-side	6	EMN22i or EMN50	—
EDOT1KT	1-gallon kit	(2) ½ gal. pails	1 kit	For bulk applications, use the EMN37A bulk mixing nozzle.	
EDOT10KT	10-gallon kit	(2) 5 gal. pails	1 kit		
EDOT100KT	100-gallon kit	(2) 50 gal. drums	1 kit		

1. Cartridge estimation guidelines are available at www.strongtie.com/apps.

2. Detailed information on dispensing tools, mixing nozzles and other adhesive accessories is available on pages 128 through 135, or at www.strongtie.com.

3. Use only Simpson Strong-Tie® mixing nozzles in accordance with Simpson Strong-Tie instructions. Modification or improper use of mixing nozzle may impair EDOT adhesive performance.

4. One EMN22i mixing nozzle and one nozzle extension are supplied with each cartridge.

Cure Schedule

Base Material Temperature		Cure Time
°F	°C	
40	4	72 hrs
60	16	24 hrs
80	27	24 hrs
100	38	24 hrs

In-Service Temperature Sensitivity

Base Material Temperature		Percent of Allowable Load
°F	°C	
40	4	100%
70	21	100%
110	43	100%
135	57	85%

Pot Life for 1 Gallon Mixed

Adhesive Temperature		Pot Life Time (min)
°F	°C	
60	16	60
70	21	35
80	27	25
90	32	15
100	38	10

Adhesive Anchoring Installation Instructions



NOTE: Always check expiration date on product label. Do not use expired product.



WARNING: When drilling and cleaning hole, use eye and lung protection. When installing adhesive, use eye and skin protection.

1 Hole Preparation – Horizontal, Vertical and Overhead Applications

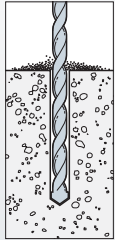

1. Drill.
Drill hole to specified diameter and depth.

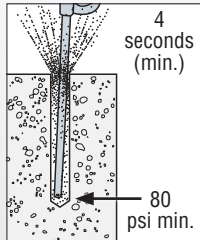

2. Blow.
Remove dust from hole with oil-free compressed air for a minimum of 4 seconds. Compressed air nozzle must reach the bottom of the hole.

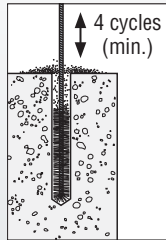

3. Brush.
Clean with a nylon brush for a minimum of 4 cycles. Brush should provide resistance to insertion. If no resistance is felt, the brush is worn and must be replaced.

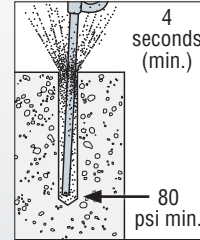

4. Blow.
Remove dust from hole with oil-free compressed air for a minimum of 4 seconds. Compressed air nozzle must reach the bottom of the hole.

Refer to page 135 or visit www.strongtie.com for proper brush part number.

2 Cartridge Preparation

1. Check.

Check expiration date on product label. **Do not use expired product.** Product is usable until end of printed expiration month.

2. Open.

Open cartridge per package instructions.

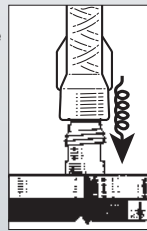

3. Attach.

Attach proper Simpson Strong-Tie® nozzle and extension to cartridge. Do not modify nozzle.

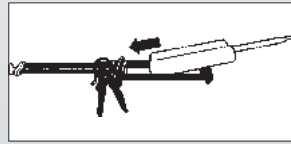

4. Insert.

Insert cartridge into dispensing tool.

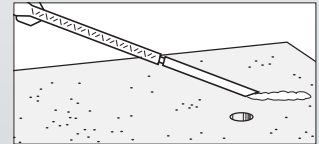

5. Dispense.

Dispense adhesive to the side until properly mixed (uniform color).

Refer to www.strongtie.com for proper mixing nozzle and dispensing tool part number.

FOR SOLID BASE MATERIALS

3A Filling the Hole – Vertical Anchorage

Prepare the hole per “Hole Preparation” instructions on product label.

DRY AND DAMP HOLES:

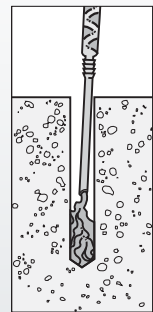

1. Fill.
Fill hole 1/2 to 3/4 full, starting from bottom of hole to prevent air pockets. Withdraw nozzle as hole fills up.

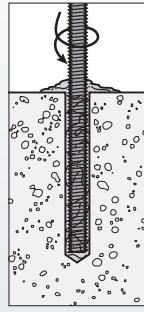

2. Insert.
Insert clean, oil-free anchor, turning slowly until the anchor contacts the bottom of the hole.

Threaded rod or rebar

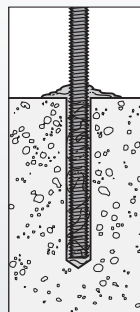

3. Do not disturb.

Do not disturb anchor until fully cured. (See cure schedule for specific adhesive.)

WATER-FILLED HOLES:

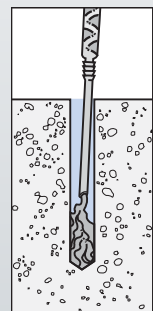

1. Fill.
Fill hole completely full, starting from bottom of hole to prevent water pockets. Withdraw nozzle as hole fills up.

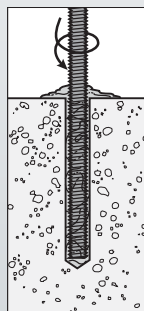

2. Insert.
Insert clean, oil-free anchor, turning slowly until the anchor contacts the bottom of the hole.

Threaded rod or rebar

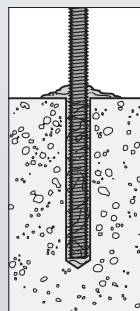

3. Do not disturb.

Do not disturb anchor until fully cured. (See cure schedule.)

Note: Nozzle extensions may be needed for deep holes.

Adhesive Anchoring Installation Instructions

3B Filling the Hole – Piston Plug Delivery System

Prepare the hole per “Hole Preparation” instructions on product label

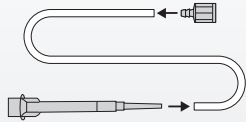

Step 1:

- Attach the piston plug to one end of the flexible tubing (PPFT25)
- Cut tubing to the length needed for the application, mark tubing as noted below and attach other end of tubing to the mixing nozzle
- If using a pneumatic dispensing tool, regulate air pressure to 80–100 psi

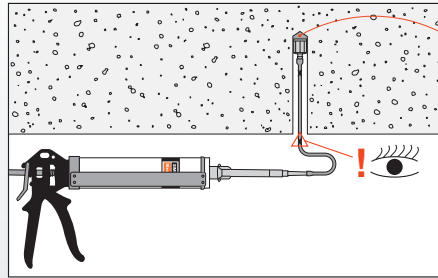
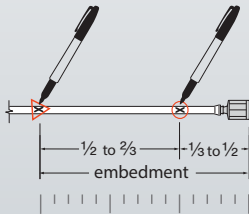

Step 2:

- Insert the piston plug to the back of the drilled hole and dispense adhesive

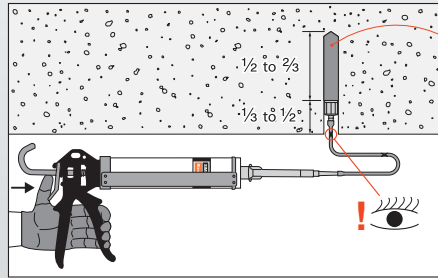

Step 3:

- Fill the hole 1/2 to 2/3 full
- **Note:** as adhesive is dispensed into the drilled hole, the piston plug will slowly displace out of the hole due to back pressure, preventing air gaps

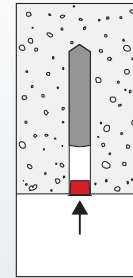

Step 4:

- Install the appropriate Simpson Strong-Tie adhesive retaining cap

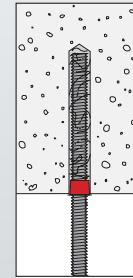

Step 5:

- Place either threaded rod or rebar through the adhesive retaining cap and into adhesive-filled hole
- Turn rod/rebar slowly until the insert bottoms out
- Do not disturb until fully cured

3C Filling the Hole – Horizontal and Overhead Anchorage with Adhesive Retaining Caps

Prepare the hole per “Hole Preparation” instructions on product label.

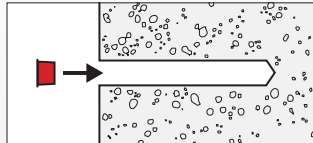

1. Install.

Install Simpson Strong-Tie® ARC adhesive retaining cap. Refer to page 132 or visit www.strongtie.com for proper ARC size.

Note: Nozzle extensions may be needed for deep holes.

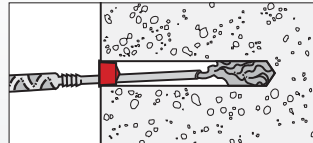

2. Fill.

Fill hole 1/2–2/3 full, starting from bottom of hole to prevent air pockets. Withdraw nozzle as hole fills up.

Threaded rod or rebar

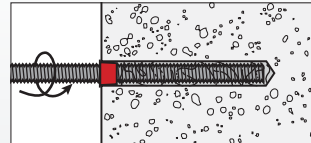

3. Insert.

Insert clean, oil-free anchor, turning slowly until the anchor contacts the bottom of the hole.

Threaded rod or rebar

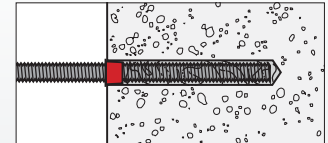

4. Do not disturb.

Do not disturb anchor until fully cured (see cure schedule).

FOR HOLLOW BASE MATERIALS

3D Filling the Hole – When Anchoring with Screens: For AT, ET-HP®, SET-XP® and SET Adhesives (except SET1.7KTA)

Prepare the hole per instructions on “Hole Preparation.”

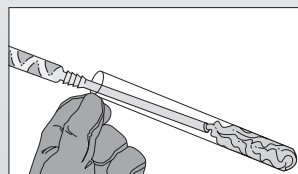

1. Fill.

Fill screen completely. Fill from the bottom of the screen and withdraw the nozzle as the screen fills to prevent air pockets. (Opti-Mesh screens: Close integral cap after filling.)

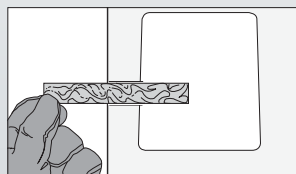

2. Insert.

Insert adhesive-filled screen into hole.

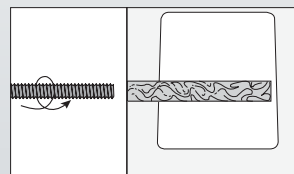

3. Insert.

Insert clean, oil-free anchor, turning slowly until the anchor contacts the bottom of the screen.

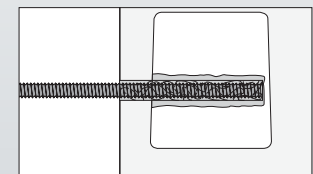

4. Do not disturb.

Do not disturb anchor until fully cured. (See cure schedule for specific adhesive.)

Installation instructions continued on page 126. →

Adhesive Anchoring Installation Instructions

FOR UNREINFORCED BRICK MASONRY

1A Hole Preparation – For Configurations A and C (Horizontal) and B (22½-Degree Downward) Installations with a Carbide-Tipped Drill Bit.

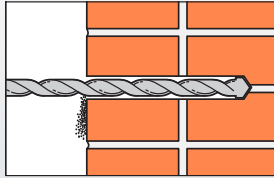

1. Drill.

Drill 1-inch-diameter hole to specified depth with a carbide-tipped drill bit, using rotation only mode. For Configurations A and C, drill 8 inches deep. For Configuration B, drill to within 1 inch of the opposite side of wall (minimum 13 inches deep).

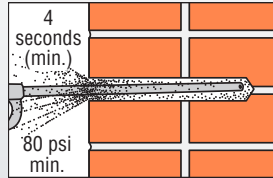

2. Blow.

Remove dust from hole with oil-free compressed air for a minimum of 4 seconds. Compressed air nozzle MUST reach the bottom of the hole.

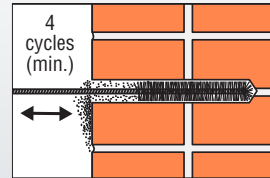

3. Brush.

Clean with a nylon brush for a minimum of 4 cycles. Brush MUST reach the bottom of the hole. Brush should provide resistance to insertion. If no resistance is felt, the brush is worn and must be replaced.

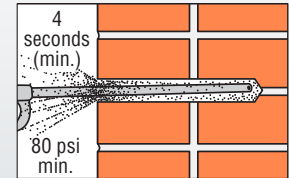

4. Blow.

Remove dust from hole with oil-free compressed air for a minimum of 4 seconds. Compressed air nozzle MUST reach the bottom of the hole.

1B Hole Preparation – For using SET Adhesive Configurations A and C (Horizontal) and B (22½-Degree Downward) Installations with a Wet Diamond Core-Drill Bit. (See page 114, footnote 4.)

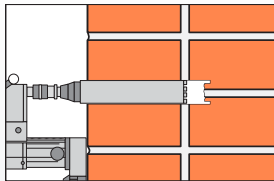

1. Drill.

Drill hole to specified depth with 1-inch-diameter wet diamond core-drill bit. For Configurations A and C, drill 8 inches deep. For Configuration B, drill to within 1 inch of the opposite side of wall (minimum 13 inches deep).

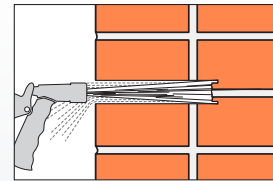

2. Flush.

Flush out hole with pressurized water until water runs clear.

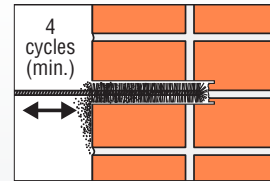

3. Brush.

Clean with a nylon brush (Simpson Strong-Tie part number ETB10) for a minimum of 4 brush strokes. Brush MUST reach the bottom of the hole. Brush should provide resistance to insertion. If no resistance is felt, the brush is worn and must be replaced.

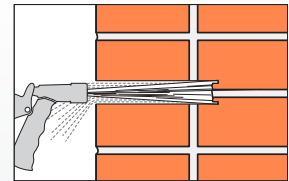

4. Flush.

Flush out hole with pressurized water until water runs clear.

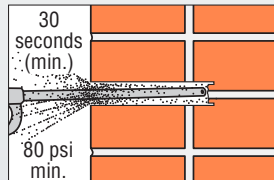

5. Blow.

Remove free standing water from hole with oil-free compressed air and blow out hole for a minimum of 30 seconds. Compressed air nozzle MUST reach the bottom of the hole.

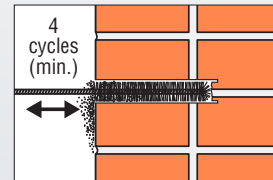

6. Brush.

Clean with a nylon brush (Simpson Strong-Tie part number ETB10) for a minimum of 4 brush strokes. Brush MUST reach the bottom of the hole. Brush should provide resistance to insertion. If no resistance is felt, the brush is worn and must be replaced.

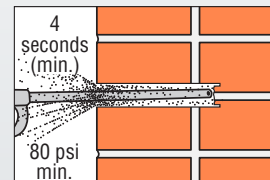

7. Blow.

Blow hole with oil-free compressed air for a minimum of 4 seconds. Compressed air nozzle MUST reach the bottom of the hole.

Adhesive Anchoring Installation Instructions

2 Cartridge Preparation

1. Check.

Check cartridge expiration date. **Do not use expired product.** Product is usable until end of printed expiration month.

2. Open.

Open cartridge per package instructions.

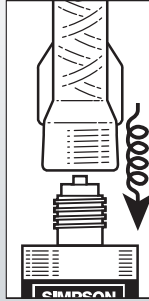

3. Attach.

Attach proper Simpson Strong-Tie® nozzle to cartridge. Do not modify nozzle.

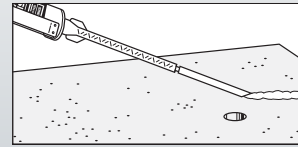
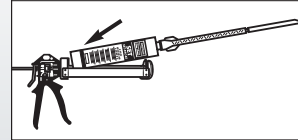

4. Insert.

Insert cartridge into dispensing tool.

5. Dispense.

Dispense adhesive to the side until properly mixed (uniform color).

3A Filling the Hole – For Configurations A (Horizontal) and B (22½ - Degree Downward) Installations.

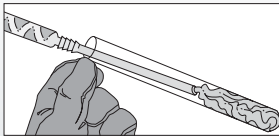

1. Fill.

Fill screen completely. Fill from the bottom of the screen and withdraw the nozzle as the screen fills to prevent air pockets. (Opti-Mesh® screens: Close integral cap after filling.)



2. Insert.

Insert adhesive filled screen into hole.

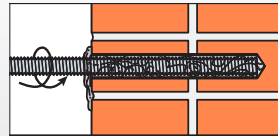

3. Insert.

Insert clean, oil-free anchor, turning slowly until the anchor contacts the bottom of the screen.

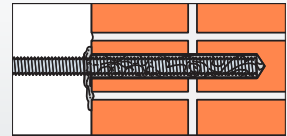

4. Do not disturb.

Do not disturb anchor until fully cured. (See cure schedule for specific adhesive.)

Note: Opti-Mesh® plastic screens or steel wire mesh screens may be used for Configurations A and B.

3B Filling the Hole – For Configuration C (Horizontal Through-Bolt) Installation.

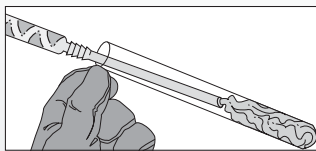

1. Fill.

Fill screen completely. Fill from the bottom of the screen and withdraw the nozzle as the screen fills to prevent air pockets.

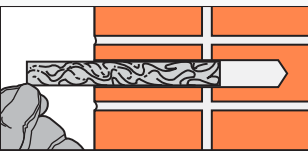

2. Insert.

Insert adhesive filled screen into hole.

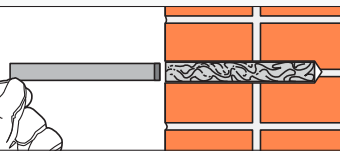

3. Insert.

Insert steel sleeve (capped end first) slowly into screen tube (adhesive will displace).

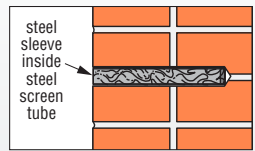

4. Cure

Allow adhesive to cure (see Cure Time Table 1).

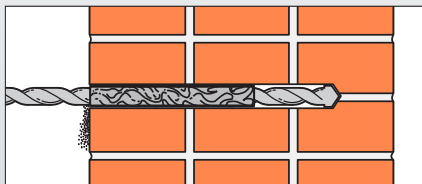

5. Drill.

Drill through plastic plug in (inside) end of steel sleeve and completely through the wall with 5/8" carbide tipped concrete drill bit (rotation mode only).

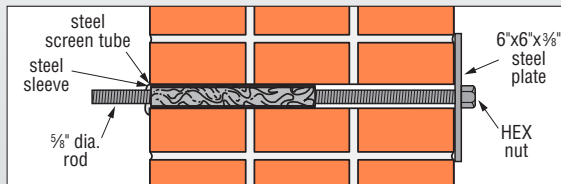

6. Insert.

Insert 5/8" rod through hole and attach metal plate and nut.

Note: Steel wire mesh screens shall be used for Configuration C.

Adhesive Accessories

Adhesive Dispensing Tools



CDT10S

Manual dispensing tool for 10 oz. single-cartridge adhesives



EDT22S

Manual dispensing tool for 22 oz. cartridges



EDTA22CKT

Battery-powered dispensing tool for 22 oz. cartridges
(kit includes two battery packs and charger)



EDTA22P

Pneumatic dispensing tool for 22 oz. cartridges



EDTA56P

Pneumatic dispensing tool for 56 oz. cartridges



ADT813S

Manual dispensing tool for 12.5 oz. cartridges



ADT30S

Manual dispensing tool for 30 oz. cartridges



ADTA30CKT

Battery-powered dispensing tool for 30 oz. cartridges
(kit includes two battery packs and charger)



ADTA30P

Pneumatic dispensing tool for 30 oz. cartridges

Adhesive Accessories

Adhesive Mixing Nozzles

EMN22i



An 18-element static mixing nozzle for use with 10 oz., 22 oz. and 56 oz. epoxy adhesive cartridges

EMN37A



An 18-element static mixing nozzle for dispensing epoxy adhesive through bulk metering equipment

EMN50



High-volume static mixing nozzle for 22 oz. and 56 oz. epoxy adhesive cartridges

AMN19Q



A 19-element, static mixing nozzle for use with 10 oz., 13 oz., and 30 oz. acrylic adhesive cartridges

For more information on adhesive dispensing tools and mixing nozzles, including ordering information, visit www.strongtie.com.

Adhesive Accessories

Piston Plug Delivery System

The Simpson Strong-Tie® Adhesive Piston Plug Delivery System offers you an easy-to-use, more reliable and less time-consuming means to dispense adhesive into drilled holes for threaded rod and rebar dowel installations at overhead, upwardly inclined and horizontal orientations.

The matched tolerance design between the piston plug and drilled hole virtually eliminates the formation of voids and air pockets during adhesive dispensing.

Features

- Designed for dispensing adhesive into drilled holes at overhead, upwardly inclined and horizontal orientations, as well as deep embedments
- Suitable for use with all Simpson Strong-Tie anchoring adhesives
- Adhesive piston plugs are sized to fit each drilled hole diameter
- Model number is embossed on each adhesive piston plug for identification
- A barbed end provides a reliable connection to the flexible extension tubing
- Flexible extension tubing is available in 25-foot-long rolls to be cut to required lengths



Adhesive Anchors



Use the piston plug delivery system with Simpson Strong-Tie® adhesive products:



Adhesive Accessories

Adhesive Piston Plugs

Model No.	Drill Bit Diameter	Pkg. Quantity	Carton Quantity*
PP56-RP10	9/16"	10	100
PP62-RP10	5/8"	10	100
PP68-RP10	1 1/16"	10	100
PP75-RP10	3/4"	10	100
PP81-RP10	13/16"	10	100
PP87-RP10	7/8"	10	100
PP100-RP10	1"	10	100
PP112-RP10	1 1/8"	10	100
PP137-RP10	1 3/8"	10	100
PP175-RP10	1 3/4"	10	100

*10 packages of 10

Adhesive Tubing

Model No.	Description	Pkg. Quantity
PPFT25	Adhesive Piston Plug Flexible Tubing — 25 ft. roll	1

Adhesive Retaining Caps

Model No.	Drill Bit Diameter	Cap Depth	Pkg. Quantity	Carton Quantity*
ARC50A-RP25	9/16"	1/2"	25	200
ARC50-RP25	5/8"	1/2"	25	200
ARC62A-RP25	1 1/16"	9/16"	25	200
ARC62-RP25	3/4"	9/16"	25	200
ARC75A-RP25	13/16"	9/16"	25	200
ARC75-RP25	7/8"	9/16"	25	200
ARC87-RP25	1"	1 1/16"	25	200
ARC100-RP25	1 1/8"	1 1/16"	25	200
ARC125-RP25	1 3/8"	7/8"	25	200
ARC137-RP25	1 3/4"	1 1/16"	25	200

*8 packages of 25



Adhesive Anchors

Installation Sequence

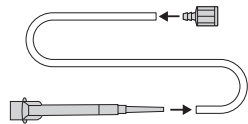

Step 1:

- Attach the piston plug to one end of the flexible tubing (PPFT25)
- Cut tubing to the length needed for the application, mark tubing as noted below and attach other end of tubing to the mixing nozzle
- If using a pneumatic dispensing tool, regulate air pressure to 80–100 psi

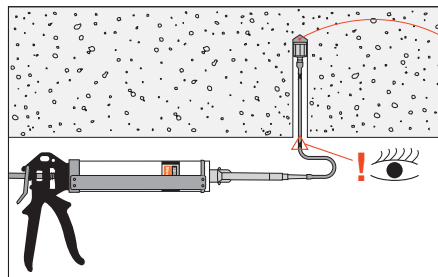
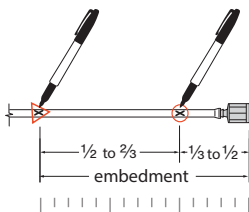

Step 2:

- Insert the piston plug to the back of the drilled hole and dispense adhesive

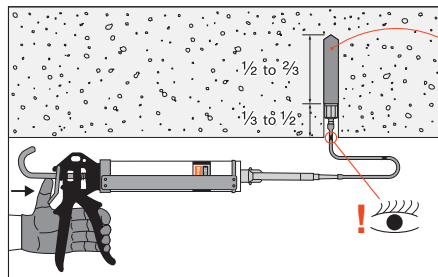

Step 3:

- Fill the hole 1/2 to 3/4 full
- Note: as adhesive is dispensed into the drilled hole, the piston plug will slowly displace out of the hole due to back pressure, preventing air gaps

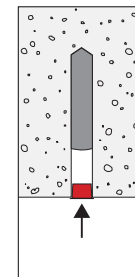

Step 4:

- Install the appropriate Simpson Strong-Tie adhesive retaining cap

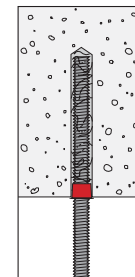

Step 5:

- Place either threaded rod or rebar through the adhesive retaining cap and into adhesive-filled hole
- Turn rod/rebar slowly until the insert bottoms out
- Do not disturb until fully cured

Adhesive Accessories

Adhesive Retaining Caps

Adhesive retaining caps make overhead and horizontal installation easier by preventing the adhesive from running out of the hole. They also center the rod in the hole, making them ideal for applications where precise anchor placement is required. It may be necessary to provide support for the insert during cure time. Adhesive retaining caps are not designed to support the weight of the insert in overhead installations.

Material: Plastic



Adhesive Retaining Caps

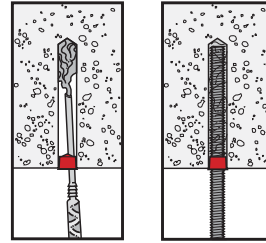

The "X" cut in the cap allows the mixing nozzle and insert to pass through, while containing the adhesive in the hole.

Adhesive Retaining Caps

Drill Bit Dia. (in.)	Anchor Diameter (in.)	Rebar Size	Model No.	Cap Depth (in.)	Package Qty.	Carton Qty.* (ea.)
7/16	3/8	#3	ARC37A-RP25	7/16	25	200
1/2	3/8		ARC37-RP25	7/16	25	200
9/16	1/2	#4	ARC50A-RP25	1/2	25	200
5/8	1/2		ARC50-RP25	1/2	25	200
11/16	5/8	#5	ARC62A-RP25	9/16	25	200
3/4	5/8		ARC62-RP25	9/16	25	200
13/16	3/4	#6	ARC75A-RP25	9/16	25	200
7/8	3/4		ARC75-RP25	9/16	25	200
1	7/8	#7	ARC87-RP25	1 1/16	25	200
1 1/16	1	#8	ARC100A-RP25	1 1/16	25	200
1 1/8	1		ARC100-RP25	1 1/16	25	200
1 3/8	1 1/4	#10	ARC125-RP25	7/8	25	200
1 3/4	—	#11	ARC137-RP25	1 1/16	25	200

*8 packages of 25.

Adhesive Accessories

Steel Adhesive-Anchoring Screen Tubes

Screen tubes are used in hollow base material applications to contain adhesive around the anchor and prevent it from running into voids. Simpson Strong-Tie® screen tubes are specifically designed to work with AT, SET and ET-HP® adhesives in order to precisely control the amount of adhesive that passes through the mesh. This results in thorough coating and bonding of the rod to the screen tube and base material. Order screen tubes based upon rod diameter and adhesive type. The actual outside diameter of the screen tube is larger than the rod diameter.

Material: Acrylic screen tubes: 50 mesh stainless steel
Epoxy screen tubes: 60 mesh carbon steel



Caution: Screen tubes are designed for a specific adhesive type. Epoxy screen tubes must be used with SET or ET-HP® formulations and acrylic screen tubes must be used with AT.

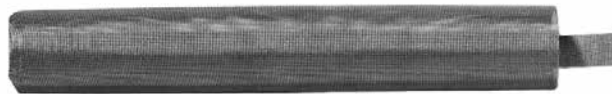

Epoxy Screen Tube
(Acrylic screen tubes similar)

Screen tubes are for use in hollow CMU, hollow brick and unreinforced masonry applications. Contact Simpson Strong-Tie for information on special-order sizes.

Acrylic Adhesive (AT) Screen Tubes – Stainless Steel

For Rod Dia. (in.)	Hole Size (in.)	Actual Screen Size O.D./Length (in.)	Model No.	Carton Qty.
3/8	9/16	15/32 X 3 1/2	ATS373	150
		15/32 X 6	ATS376	150
1/2	1 1/16	19/32 X 3 1/2	ATS503	100
		19/32 X 6	ATS506	100
		19/32 X 10	ATS5010	50
5/8	7/8	25/32 X 3	ATS623	50
		25/32 X 6	ATS626	50
		25/32 X 10	ATS6210	25
		25/32 X 13	ATS6213	25
3/4	1	31/32 X 8	ATS758	25
		31/32 X 13	ATS7513	25
		31/32 X 17	ATS7517	25

Epoxy Adhesive (SET and ET-HP®) Screen Tubes – Carbon Steel

For Rod Dia. (in.)	Hole Size (in.)	Actual Screen Size O.D./Length (in.)	Model No.	Carton Qty.
3/8	9/16	15/32 X 6	ETS376	150
		15/32 X 10	ETS3710	100
1/2	1 1/16	19/32 X 6	ETS506	100
		19/32 X 10	ETS5010	50
5/8	7/8	25/32 X 6	ETS626	50
		25/32 X 10	ETS6210	25
		25/32 X 13	ETS6213	25
3/4	1	31/32 X 8	ETS758	25
		31/32 X 13	ETS7513	25
		31/32 X 17	ETS7517	25
		31/32 X 21	ETS7521	25

Note: Not for use with SET1.7KTA.

Adhesive Accessories

Opti-Mesh Adhesive-Anchoring Screen Tubes

Screen tubes are vital to the performance of adhesive anchors in base materials that are hollow or contain voids, such as hollow block and brick. The Simpson Strong-Tie® Opti-Mesh screen tube provides the economical advantage of a plastic screen tube while providing performance comparable to steel screen tubes and better than competitive plastic screen tubes.

Material: Plastic

⚠ Caution: Screen tubes are designed for a specific adhesive type. Epoxy screen tubes must be used with SET-XP®, ET-HP® or SET formulations, and acrylic adhesive screen tubes must be used with AT.

Adhesive Anchors



Epoxy Adhesive Screen Tube
(mesh is black)



The integral cap centers the rod and displays drill bit and rod diameter.



Acrylic Adhesive Screen Tube
(mesh is white)

Epoxy Adhesive (SET-XP®, ET-HP® and SET) Screen Tubes – Plastic

For Rod Dia. (in.)	Hole Size (in.)	Length (in.)	Model No.	Carton Qty.
3/8	5/16	3 1/2	ETS373P	150
		6	ETS376P	150
		10	ETS3710P	100
1/2	3/4	3 1/2	ETS503P	100
		6	ETS506P	100
		10	ETS5010P	50
5/8	7/8	3 1/2	ETS623P	50
		6	ETS626P	50
		10	ETS6210P	25
		13	ETS6213P	25
3/4	1	8	ETS758P	25
		13	ETS7513P	25
		17	ETS7517P	25
		21	ETS7521P	25

Not for use with SET1.7KTA.

Acrylic Adhesive (AT) Screen Tubes – Plastic

For Rod Dia. (in.)	Hole Size (in.)	Length (in.)	Model No.	Carton Qty.
3/8	5/16	3 1/2	ATS373P	150
		6	ATS376P	150
		10	ATS3710P	100
1/2	3/4	3 1/2	ATS503P	100
		6	ATS506P	100
		10	ATS5010P	50
5/8	7/8	3 1/2	ATS623P	50
		6	ATS626P	50
		10	ATS6210P	25
		13	ATS6213P	25
3/4	1	8	ATS758P	25
		13	ATS7513P	25
		17	ATS7517P	25
		21	ATS7521P	25

Adhesive Accessories

Hole-Cleaning Brushes

Brushes are used for cleaning drilled holes prior to adhesive anchor installation. Brushes have a twisted wire handle with nylon bristles.

Description	Model No.	For Anchor/Rebar Diameter (in.)	For Hole Diameter (in.)	Ctn Qty
½" dia x 3" brush (8" total length)	ETB4	¼" – ⅝"	⅜" – 7/16"	24
¾" x 4" brush (16" total length)	ETB6	⅜" – ⅝"	½" – ¾"	24
1" x 4" brush (16" total length)	ETB8	¾"	1⅜" – 7/8"	24
1" x 4" brush (24" total length)	ETB8L	¾"	1⅜" – 7/8"	24
1¼" x 4" brush (29" total length)	ETB10	7/8" – 1"	1" – 1½"	24
1⅝" x 6" brush (34" total length)	ETB12	1¼"	1⅜" – 1⅝"	24

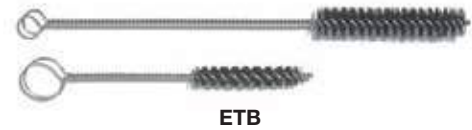

ETB

Adhesive Shear Tubes

Used in conjunction with anchoring adhesive and screen tubes, adhesive shear tubes transfer anchor shear loads over a larger area, reducing localized crushing in unreinforced masonry installations. Required for through-bolt applications per ICC-ES's unreinforced masonry anchorage "Configuration C" detail. For detailed installation instructions, refer to the appropriate adhesive anchor ICC-ES report.



Adhesive Shear Tube

MATERIAL: Steel

FINISH: Zinc-plated

Description (in.)	Model No.	For use with Simpson Screen Model No. ¹	Drill Bit Dia. (in.)	Threaded Rod Diameter (in.)	Carton Qty.
1⅜" x 8	AST800	ETS758, ATS758	1	⅝"	1

1. Screens sold separately. Not for use with Simpson Strong-Tie screen ETS758P or ATS758P plastic Opti-Mesh screen tubes.

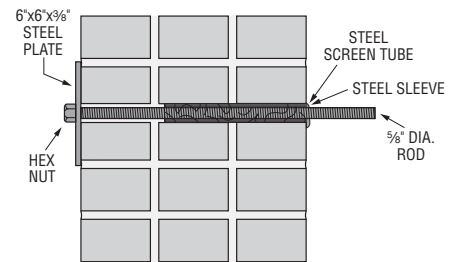

Configuration C

Retrofit Bolts

RFBs are pre-cut threaded rod, supplied with nut and washer. For use with Simpson Strong-Tie® adhesives. May be ordered in bulk without the nut and washer. Use with Simpson Strong-Tie adhesives to anchor into existing concrete and masonry. Each end of the threaded rod is stamped with rod length in inches and our "No-Equal" symbol for easy identification after installation.

MATERIAL: ASTM F1554 Grade 36

COATING: Zinc-plated, hot-dip galvanized

Description Dia. Length	Zinc-Plated Model No.	Hot-Dip Galvanized Model No.	Ctn Qty	Retail ² Pack
½" x 4"	RFB#4x4	RFB#4x4HDG	50	—
½" x 5"	RFB#4x5	RFB#4x5HDG	50	10
½" x 6"	RFB#4x6	RFB#4x6HDG	50	10
½" x 7"	RFB#4x7	RFB#4x7HDG	50	10
½" x 8"	—	RFB#4x8HDG	—	10
½" x 10"	RFB#4x10	RFB#4x10HDG	25	10
⅝" x 5"	RFB#5x5	RFB#5x5HDG	50	10
⅝" x 8"	RFB#5x8	RFB#5x8HDG	50	10
⅝" x 10"	RFB#5x10	RFB#5x10HDG	50	10
⅝" x 12"	—	RFB#5x12HDG	—	10
⅝" x 16"	RFB#5x16	RFB#5x16HDG	25	10
¾" x 10½"	RFB#6x10.5	RFB#6x10.5HDG	25	—



RFB Retrofit Bolts

1. Bulk quantities do not include the nut and washer and must be ordered with a "-B" suffix (example: RFB#4x5-B). Hot-dip galvanized RFBs not available in bulk.
2. Retail packs must be ordered with a "-R" suffix (example: RFB#5x12HDG-R).

Mechanical Anchors



From complex infrastructure projects to do-it-yourself ventures, Simpson Strong-Tie offers a wide variety of anchoring products to meet virtually any need.

Our mechanical anchors are designed to install easily and securely into a variety of base materials — from concrete and brick to hollow and grouted CMU. They offer optimal performance even in the most demanding structural applications. For applications where there is a risk of concrete cracking, specific anchors have been designed and tested to offer reliability under these conditions.



Torq-Cut™ Self-Undercutting Anchor



The Torq-Cut™ self-undercutting anchor is a heavy-duty, high-capacity anchor developed and tested for use in cracked and uncracked concrete under static and seismic conditions. The Torq-Cut features a built-in, hardened cutting ring that expands with installation torque, forming undercut grooves in the concrete. This interlock between the anchor and the concrete provides superior load-carrying capacity.

Features

- Code listed under IBC/IRC for cracked and uncracked concrete per ICC-ES ESR-2705
- Self-undercutting feature provides higher load-carrying capacity than conventional mechanical anchors
- Qualified for static and seismic loading conditions (seismic design categories A through F)
- Ductile steel rod provides consistent, reliable performance
- Specially designed, low-friction expansion cone minimizes binding and speeds installation
- Installation requires no special drill bit or secondary drilling operation
- Head is stamped with the Simpson Strong-Tie® “#” sign and anchor size identification for easy post-installation verification

Codes: ICC-ES ESR-2705 (concrete); City of L.A. RR25946 (concrete); Florida FL-15731.3

Material: Carbon steel

Coating: Zinc plated or sherardized*

Torq-Cut™ Setting Tool

The TCAST is the steel setting tool used to install the Torq-Cut self-undercutting anchor, driving the anchor into the pre-drilled hole and protecting the threads on the Torq-Cut anchor from being damaged by hammer blows.



**Torq-Cut™
Self-Undercutting Anchor**
U.S. Patent 7,357,613



**Torq-Cut™
Setting Tool**
(Sold separately)

Installation Instructions: Pre-Set Version

1. Drill a hole in the base material to the specified embedment depth using the appropriate diameter carbide drill bit specified for each diameter.
2. Blow the hole clean using compressed air.
3. Assemble the anchor with nut and washer, and finger-tighten the nut so all components are snug (spacer sleeve, expansion sleeve and cone). The bottom of the threaded rod should be flush with the bottom of the cone.
4. Place the anchor in the drilled hole, and use a hammer and setting tool to drive the anchor until the washer and nut are tight against the surface of the base material.
5. Remove the nut and washer and install the fixture. Reassemble the nut and washer over the fixture.
6. Tighten to the required installation torque.

Installation Instructions: Through-Set Version

1. Drill a hole in the base material to the specified embedment depth using the appropriate diameter carbide drill bit specified for each diameter.
2. Blow the hole clean using compressed air.
3. Assemble the anchor with nut and washer and finger-tighten the nut so all components are snug (spacer sleeve, expansion sleeve and cone). The bottom of the threaded rod should be flush with the bottom of the cone.
4. Place the anchor through the fixture and into the drilled hole. Use a hammer and setting tool to drive the anchor until the washer and nut are tight against the fixture.
5. Tighten to the required installation torque.



Caution: Oversized holes in the base material will make it difficult to set the anchor and will reduce the anchor's load capacity. Do not install in holes drilled with core drill bit.

Pre-Set and Through-Set Version

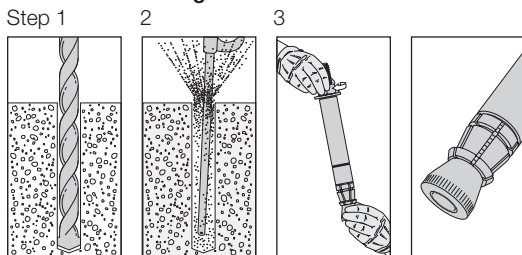

Pre-Set Version

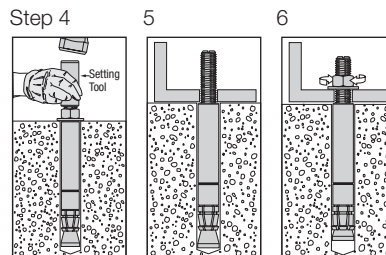

Through-Set Version

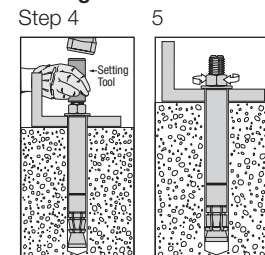

Torq-Cut™ Self-Undercutting Anchor

Torq-Cut™ Anchor Product Data, Pre-Set Version¹

Size (in.)	Model No.	Drill Bit Dia. (in.)	Min. Drilled Hole Depth (A) (in.)	Min. Nominal Embedment Depth, h_{nom} (B) (in.)	Max. Fixture Thickness (F) (in.)	Min. Fixture Hole Dia. (in.)	Threaded Rod Length (D) (in.)	Quantity	
								Box	Carton
1/2 x 8 3/4	TCAP500834	7/8	7	6 5/8	1 1/4	9/16	8 3/4	5	10
1/2 x 9 1/2	TCAP500912	7/8	7	6 5/8	2	9/16	9 1/2	5	10
5/8 x 11 1/2	TCAP621112	1	9 1/2	8 7/8	1 1/2	1 1/16	11 1/2	4	8
5/8 x 12 1/2	TCAP621212	1	9 1/2	8 7/8	2 1/2	1 1/16	12 1/2	4	8
3/4 x 14 5/8	TCAP751458	1 1/4	12	11 3/8	2	13/16	14 5/8	4	8
3/4 x 16 5/8	TCAP751658	1 1/4	12	11 3/8	4	13/16	16 5/8	4	8

1. See Figure 1 below.

Torq-Cut™ Anchor Product Data, Through-Set Version¹

Size (in.)	Model No.	Drill Bit Dia. (in.)	Min. Drilled Hole Depth (A) (in.)	Min. Nominal Embedment Depth, h_{nom} (B) (in.)	Max. Fixture Thickness (F) (in.)	Min. Fixture Hole Dia. (in.)	Threaded Rod Length (D) (in.)	Quantity	
								Box	Carton
1/2 x 8 3/4	TCAT500834	7/8	7	6 5/8	1 1/4	15/16	8 3/4	5	10
1/2 x 9 1/2	TCAT500912	7/8	7	6 5/8	2	15/16	9 1/2	5	10
5/8 x 11 1/2	TCAT621112	1	9 1/2	8 7/8	1 1/2	1 1/16	11 1/2	4	8
5/8 x 12 1/2	TCAT621212	1	9 1/2	8 7/8	2 1/2	1 1/16	12 1/2	4	8
3/4 x 14 5/8	TCAT751458	1 1/4	12	11 3/8	2	1 5/16	14 5/8	4	8
3/4 x 16 5/8	TCAT751658	1 1/4	12	11 3/8	4	1 5/16	16 5/8	4	8

1. See Figure 1 below.

Torq-Cut™ Anchor Material Specifications*

Carbon Steel Component Materials						
	Threaded Rod	Nut	Washer	Spacer Sleeve	Undercut Expansion Ring	Expansion Cone
Material	ASTM A193 Grade B7M	SAE J995, Grade 8	ASTM F436, Type 1	SAE J403 Grade 1045 Steel	SAE J403 Grade 1045 Steel	SAE J403 Grade 1144 Steel
Coating	Zinc Plated ASTM B633 SC1	Zinc plated	Zinc plated	Zinc Plated ASTM B633 SC1	Zinc Plated ASTM B633 SC1	Zinc Plated ASTM B633 SC1

*For added corrosion resistance, TCA with a sherardized coating is available by special order.

Torq-Cut™ Anchor Installation Data

Nominal Anchor Dia (in.)	1/2	5/8	3/4
Drill Bit Size (in.)	7/8	1	1 1/4
Fixture Hole Dia Range Pre-Set (in.)	9/16-3/4	1 1/16-7/8	13/16-1 1/8
Min. Fixture Hole Dia Through-Set (in.)	15/16	1 1/16	1 5/16
Wrench Size (in.)	3/4	15/16	1 1/8
Setting Tool Required	TCAST50	TCAST62	TCAST75

- The Drilled Hole Depth is 1/2" greater than the Nominal Embedment Depth.
- For the Through-Set version of the Torq-Cut anchor, if the actual Fixture Thickness (t_{fx}) is less than the Maximum Fixture Thickness (F), the Minimum Drilled Hole Depth (A) must be increased as follows:

$$\text{Drilled Hole Depth} = A + (F - t_{fx})$$
 Similarly, the Minimum Nominal Embedment Depth (B) is increased as follows:

$$\text{Nominal Embedment Depth} = B + (F - t_{fx})$$

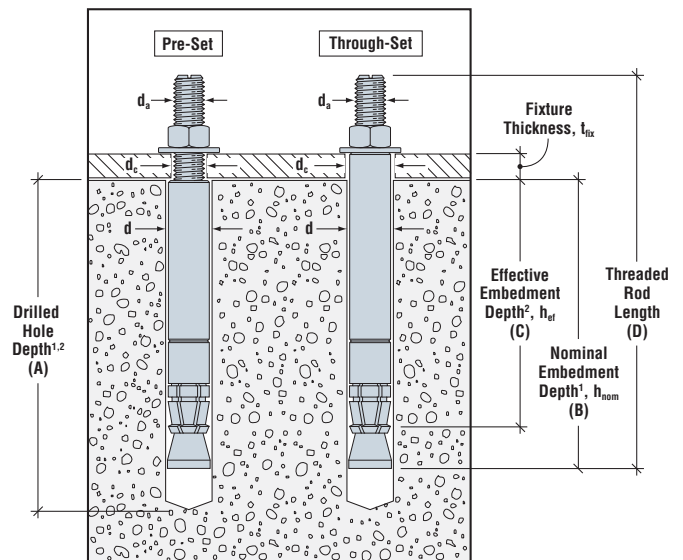

Figure 1
Drilled Hole Depth

Torq-Cut™ Design Information — Concrete

Torq-Cut™ Anchor Installation and Additional Data¹

Characteristic	Symbol	Units	Nominal Anchor Diameter (in.)		
			1/2	5/8	3/4
Installation Information					
Drill Bit Diameter	d	in.	7/8	1	1 1/4
Pre-Set Fixture Hole Diameter Range ²	d_c	in.	9/16–3/4	1 1/16–7/8	1 3/16–1 1/8
Through-Set Minimum Fixture Hole Diameter ²	d_c	in.	15/16	1 1/16	1 5/16
Installation Torque	T_{inst}	ft.-lb.	90	185	240
Minimum Nominal Embedment Depth	h_{nom}	in.	6 5/8	8 7/8	11 3/8
Minimum Overall Depth of Drilled Hole	h_{hole}	in.	7	9 1/2	12
Critical Edge Distance	c_{ac}	in.	8 5/8	12	15 3/8
Minimum Edge Distance	c_{min}	in.	7	10	7 3/4
Minimum Spacing	s_{min}	in.	7	9	7 3/4
Minimum Concrete Thickness	h_{min}	in.	8 5/8	12	15 3/8
Additional Data					
Anchor Category	Category	—	1	1	1
Yield Strength	f_{ya}	ksi	80	80	80
Tensile Strength	f_{uta}	ksi	100	100	100
Effective Tensile and Shear Stress Area	A_{se}	in ²	0.142	0.226	0.334
Axial Stiffness in Service Load Range – uncracked concrete	β_{uncr}	lb./in.	635,830		
Axial Stiffness in Service Load Range - cracked concrete	β_{cr}	lb./in.	346,694		

- The information presented in this table is to be used in conjunction with the design criteria of ACI 318 Appendix D.
- The clearance must comply with applicable code requirements for the connected element.



Torq-Cut™ Tension Strength Design Data¹

Characteristic	Symbol	Units	Nominal Anchor Diameter (in.)		
			1/2	5/8	3/4
Minimum Nominal Embedment Depth	h_{nom}	in.	6 5/8	8 7/8	11 3/8
Steel Strength in Tension					
Nominal Steel Strength in Tension	N_{sa}	lb.	14,190	22,600	33,450
Strength Reduction Factor – Steel Failure	ϕ_{sa}	—	0.75 ²		
Concrete Breakout Strength in Tension ⁶					
Minimum Effective Embedment Depth	h_{ef}	in.	5 3/4	8	10 1/4
Critical Edge Distance	c_{ac}	in.	8 5/8	12	15 3/8
Effectiveness Factor – Uncracked Concrete	k_{uncr}	—	24	24	24
Effectiveness Factor – Cracked Concrete	k_{cr}	—	21	17	21
Modification Factor	$\psi_{c,N}$	—	1.0	1.0	1.0
Strength Reduction Factor – Concrete Breakout Failure	ϕ_{cb}	—	0.65 ⁵		
Pullout Strength in Tension ⁶					
Pullout Strength Uncracked Concrete	$N_{p,uncr}$	lb	N/A ³	N/A ³	N/A ³
Pullout Strength Cracked Concrete	$N_{p,cr}$	lb	N/A ³	N/A ³	N/A ³
Strength Reduction Factor - Pullout Failure	ϕ_p	—	N/A ³	N/A ³	N/A ³
Tension Resistance for Seismic Applications ⁶					
Tension Resistance - Seismic Loads	N_{eq}	lb	14,190	22,600	33,450
Strength Reduction Factor – Steel Failure	ϕ_{sa}	—	0.75 ²		

- The information presented in this table must be used in conjunction with the design criteria of ACI 318 Appendix D, except as modified below.
- The tabulated value of ϕ_{sa} applies when the load combinations of Section 1605.2.1 of the IBC, or ACI 318 Section 9.2 are used. If the load combinations of ACI 318 Appendix C are used, the appropriate value of ϕ_{sa} must be determined in accordance with ACI 318 D.4.4. Torq-Cut™ anchors are ductile steel elements as defined in ACI 318 D.1.
- N/A (Not Applicable) denotes that pullout resistance does not need to be considered.
- The tabulated value of ϕ_p applies when the load combinations of Section 1605.2.1 of the IBC, or ACI 318 Section 9.2 are used and the requirements of ACI 318 D.4.3(c) for Condition B are met. If the load combinations of ACI 318 Appendix C are used, appropriate value of ϕ must be determined in accordance with ACI 318 Section D.4.4(c).
- The tabulated value of ϕ_{cb} applies when both the load combinations of Section 1605.2.1 of the IBC, or ACI 318 Section 9.2 are used and the requirements of ACI 318 Section D.4.3(c) for Condition B are met. Condition B applies where supplementary reinforcement is not provided. For installations where supplementary reinforcement can be verified, the ϕ_{cb} factors described in ACI 318 D.4.3 for Condition A are allowed. If the load combinations of ACI 318 Section 9.2 are used and the requirements of ACI 318 Section D.4.3 for Condition A are met, the appropriate value of ϕ_{cb} must be determined in accordance with ACI 318 D.4.3(c). If the load combinations of ACI 318 Appendix C are used, the appropriate value of ϕ_{cb} must be determined in accordance with ACI 318 D.4.4(c).
- For sand-lightweight concrete, in lieu of ACI 318 Section D.3.6, modify the value of concrete breakout strength, $N_{p,cr}$, $N_{p,uncr}$ and N_{eq} by 0.6. All-lightweight concrete is beyond the scope of this table.
- Pullout strength applies for 2,500 psi $\leq f'_c \leq$ 3,500 psi concrete. For $f'_c >$ 3,500 psi concrete, pullout strength need not be considered since steel controls for concrete strengths greater than 3,500 psi.

* See page 12 for an explanation of the load table icons.

Torq-Cut™ Design Information — Concrete

Torq-Cut™ Shear Strength Design Data¹

Characteristic	Symbol	Units	Nominal Anchor Diameter (in.)		
			1/2	5/8	3/4
Nominal Embedment Depth	h_{nom}	in.	6%	8%	11%
Steel Strength in Shear					
Pre-Set Configuration: Steel Strength in Shear	V_{sa}	lb.	8,515	13,560	20,070
Through-Set Configuration: Steel Strength in Shear	V_{sa}	lb.	26,065	38,720	49,235
Strength Reduction Factor – Steel Failure	ϕ_{sa}	—	0.65 ²		
Concrete Breakout Strength in Shear⁵					
Outside Diameter	d_a	in.	7/8	1	1 1/4
Load Bearing Length of Anchor in Shear	ℓ_e	in.	4.3	5.8	7.5
Strength Reduction Factor – Concrete Breakout Failure	ϕ_{cb}	—	0.70 ³		
Concrete Pryout Strength in Shear					
Coefficient for Pryout Strength	k_{cp}	lb.	2.0		
Strength Reduction Factor – Concrete Pryout Failure	ϕ_{cp}	—	0.70 ⁴		
Steel Strength in Shear for Seismic Applications					
Pre-Set Configuration: Steel Strength in Shear for Seismic Loads	V_{eq}	lb.	8,515	13,560	20,070
Through-Set Configuration: Steel Strength in Shear for Seismic Loads	V_{eq}	lb.	15,640	30,975	44,310
Strength Reduction Factor – Steel Failure	ϕ_{sa}	—	0.65 ²		

- The information presented in this table must be used in conjunction with the design criteria of ACI 318 Appendix D, except as modified below.
- The tabulated value of ϕ_{sa} applies when the load combinations of Section 1605.2.1 of the IBC or ACI 318 Section 9.2 are used and the requirements of ACI 318 D.4.3 (c) for Condition B are met. If the load combinations of ACI 318 Appendix C are used, the appropriate value of ϕ_{sa} must be determined in accordance with ACI 318 D.4.4. Torq-Cut™ anchors are ductile steel elements as defined in ACI 318 D.1.
- The tabulated value of ϕ_{cb} applies when both the load combinations of Section 1605.2.1 of the IBC or ACI 318 Section 9.2 are used and the requirements of ACI 318 D.4.3(c) for Condition B are met. Condition B applies where supplementary reinforcement is not provided. For installations where complying supplementary reinforcement can be verified, the ϕ_{cb} factors described in ACI 318 D.4.3 for Condition A are allowed. If the load combinations of ACI 318 Section 9.2 are used and the requirements of ACI 318 Section D.4.3 for Condition A are met, the appropriate value of ϕ_{cb} must be determined in accordance with ACI 318 D.4.3(c). If the load combinations of ACI 318 Appendix C are used, the appropriate value of ϕ_{cb} must be determined in accordance with ACI 318 D.4.4(c).
- The tabulated value of ϕ_{cp} applies when both the load combinations of Section 1605.2.1 of the IBC or ACI 318 Section 9.2 are used and the requirements of ACI 318 D.4.3(c) for Condition B are met. If the load combinations of ACI 318 Appendix C are used, appropriate value of ϕ_{cp} must be determined in accordance with ACI 318 Section D.4.4(c).
- For sand-lightweight concrete, in lieu of ACI 318 Section D.3.6, modify the value of concrete breakout strength by 0.6. All-lightweight concrete is beyond the scope of this table.

* See page 12 for an explanation of the load table icons.

Torq-Cut™ Design Information — Concrete

Torq-Cut™ Tension Design Strengths in Normal-Weight Concrete ($f'_c = 2,500$ psi)

Anchor Dia. (in.)	Nominal Embed. Depth (in.)	Min. Concrete Thickness h_{min} (in.)	Critical Edge Distance c_{ac} (in.)	Minimum Edge Distance c_{min} (in.)	Tension Design Strength (lb.)							
					Edge Distances = c_{ac} on all sides				Edge Distances = c_{min} on one side and c_{ac} on three sides			
					SDC A-B ⁵		SDC C-F ^{6,7}		SDC A-B ⁵		SDC C-F ^{6,7}	
					Uncracked	Cracked	Uncracked	Cracked	Uncracked	Cracked	Uncracked	Cracked
1/2	6%	8%	8%	7	10,645	9,410	8,065	7,060	9,190	8,040	6,895	6,030
5/8	8%	12	12	10	16,950	12,500	13,235	9,375	15,370	10,885	11,525	8,165
3/4	11%	15%	15%	7 3/4	25,090	22,395	19,195	16,800	16,385	14,335	12,290	10,755

1. Tension design strengths are based on the strength design provisions of ACI 318-11 Appendix D.
2. Tabulated values are for a single anchor with no influence of another anchor.
3. Interpolation between embedment depths is not permitted.
4. Strength reduction factor, ϕ , is based on using a load combination from ACI 318-11 Section 9.2.
5. The tension design strength listed for SDC (Seismic Design Category) A-B may also be used in SDC C-F when the tension component of the strength-level seismic design load on the anchor does not exceed 20% of the total factored tension load on the anchor associated with the same load combination.
6. When designing anchorages in SDC C-F, the designer shall consider the ductility requirements of ACI 318-11 Section D.3.3.
7. Tension design strengths in SDC C-F have been adjusted by 0.75 factor in accordance with ACI 318-11 Section D.3.3.4.4.

Torq-Cut™ Allowable Tension Loads in Normal-Weight Concrete ($f'_c = 2,500$ psi) — Static Load

Anchor Dia. (in.)	Nominal Embed. Depth (in.)	Min. Concrete Thickness h_{min} (in.)	Critical Edge Distance c_{ac} (in.)	Minimum Edge Distance c_{min} (in.)	Allowable Tension Load (lb.)			
					Edge Distances = c_{ac} on all sides		Edge Distances = c_{min} on one side and c_{ac} on three sides	
					Uncracked	Cracked	Uncracked	Cracked
1/2	6%	8%	8%	7	7,605	6,720	6,565	5,745
5/8	8%	12	12	10	12,105	8,930	10,980	7,775
3/4	11%	15%	15%	7 3/4	17,920	15,995	11,705	10,240

1. Allowable tension loads are calculated based on the strength design provision of ACI 318-11 Appendix D using a conversion factor of $\alpha = 1.4$. The conversion factor α is based on the load combination 1.2D + 1.6L assuming 50% dead load and 50% live load: $1.2(0.5) + 1.6(0.5) = 1.4$.
2. Tabulated values are for a single anchor with no influence of another anchor.
3. Interpolation between embedment depths is not permitted.

* See page 12 for an explanation of the load table icons.

Torq-Cut™ Design Information — Concrete

Torq-Cut™ Allowable Tension Loads in Normal-Weight Concrete
($f'_c = 2,500$ psi) — Wind Load

Anchor Dia. (in.)	Nominal Embed. Depth (in.)	Min. Concrete Thickness h_{min} (in.)	Critical Edge Distance c_{ac} (in.)	Minimum Edge Distance c_{min} (in.)	Allowable Tension Load (lb.)			
					Edge Distances = c_{ac} on all sides		Edge Distances = c_{min} on one side and c_{ac} on three sides	
					Uncracked	Cracked	Uncracked	Cracked
1/2	6%	8%	8%	7	6,385	5,645	5,515	4,825
5/8	8%	12	12	10	10,170	7,500	9,220	6,530
3/4	11%	15%	15%	7 3/4	15,055	13,435	9,830	8,600

1. Allowable tension loads are calculated based on the strength design provision of ACI 318-11 Appendix D using a conversion factor of $\alpha = 1/0.6 = 1.67$. The conversion factor α is based on the load combination assuming 100% wind load.
2. Tabulated values are for a single anchor with no influence of another anchor.
3. Interpolation between embedment depths is not permitted.

Torq-Cut™ Allowable Tension Loads in Normal-Weight Concrete
($f'_c = 2,500$ psi) — Seismic Load

Anchor Dia. (in.)	Nominal Embed. Depth (in.)	Min. Concrete Thickness h_{min} (in.)	Critical Edge Distance c_{ac} (in.)	Minimum Edge Distance c_{min} (in.)	Allowable Tension Load (lb.)							
					Edge Distances = c_{ac} on all sides				Edge Distances = c_{min} on one side and c_{ac} on three sides			
					SDC A-B ⁴		SDC C-F ^{5,6}		SDC A-B ⁴		SDC C-F ^{5,6}	
					Uncracked	Cracked	Uncracked	Cracked	Uncracked	Cracked	Uncracked	Cracked
1/2	6%	8%	8%	7	7,450	6,585	5,645	4,940	6,435	5,630	4,825	4,220
5/8	8%	12	12	10	11,865	8,750	9,265	6,565	10,760	7,620	8,070	5,715
3/4	11%	15%	15%	7 3/4	17,565	15,675	13,435	11,760	11,470	10,035	8,605	7,530

1. Allowable tension loads are calculated based on the strength design provision of ACI 318-11 Appendix D using a conversion factor of $\alpha = 1/0.7 = 1.43$. The conversion factor α is based on the load combination assuming 100% seismic load.
2. Tabulated values are for a single anchor with no influence of another anchor.
3. Interpolation between embedment depths is not permitted.
4. The allowable tension load listed for SDC (Seismic Design Category) A-B may also be used in SDC C-F when the tension component of the strength-level seismic design load on the anchor does not exceed 20% of the total factored tension load on the anchor associated with the same load combination.
5. When designing anchorages in SDC C-F, the designer shall consider the ductility requirements of ACI 318-11 Section D.3.3.
6. Tension design strengths in SDC C-F have been adjusted by 0.75 factor in accordance with ACI 318-11 Section D.3.3.4.4.

* See page 12 for an explanation of the load table icons.

Strong-Bolt® 2 Wedge Anchor

A wedge-type expansion anchor designed for optimal performance in cracked and uncracked concrete as well as uncracked masonry. The Strong-Bolt® 2 is available in carbon steel (¼" through 1" diameter), Type 304 (¼" diameter only) and Type 316 stainless steel (¼" through ¾" diameter).



Features

- Code listed under IBC/IRC for cracked and uncracked concrete per ICC-ES ESR-3037
- Code listed under IBC/IRC for masonry per IAPMO UES ER-240
- Qualified for static and seismic loading conditions (seismic design categories A through F)
- Suitable for horizontal, vertical and overhead applications
- Qualified for minimum concrete thickness of 3¼", and lightweight concrete-over-metal deck thickness of 2½" and 3¼"
- Standard (ANSI) fractional sizes: fits standard fixtures and installs with common drill bit and tool sizes

Codes: ICC-ES ESR-3037 (concrete); IAPMO UES ER-240 (carbon steel in CMU); City of L.A. RR25891 (concrete), RR25936 (carbon steel in CMU); Florida FL-15731.2; FL-16230.4; UL File Ex3605; FM 3043342 and 3047639; Multiple DOT listings; meets the requirements of Federal Specifications A-A-1923A, Type 4

Material: Carbon-steel stud with special alloy clip; stainless-steel stud with stainless-steel clip

Coating: Zinc plated



Strong-Bolt® 2 Wedge Anchor



Head Stamp

The head is stamped with the length identification letter, bracketed top and bottom by horizontal lines.

Material Specifications

Anchor Body	Nut	Washer	Clip
Carbon Steel ¹	Carbon Steel, ASTM A 563, Grade A	Carbon Steel ASTM F844	Carbon Steel ASTM A 568
Type 304 Stainless Steel	Type 304 Stainless Steel	Type 304 Stainless Steel	Type 316 Stainless Steel
Type 316 Stainless Steel	Type 316 Stainless Steel	Type 316 Stainless Steel	Type 316 Stainless Steel

1. Zinc meets ASTM B 633, Class SC 1 (Fe / Zn 5), Type III.

Strong-Bolt® 2 Anchor Installation Data

Strong-Bolt 2 Dia. (in.)	¼	⅜	½	⅝	¾	⅞	1
Drill Bit Size (in.)	¼	⅜	½	⅝	¾	⅞	1
Min. Fixture Hole (in.)	⅝	⅞	9/16	11/16	7/8	1	1 1/8
Wrench Size (in.)	7/16	9/16	¾	15/16	1 1/8	1 5/16	1 ½

Length Identification Head Marks on Strong-Bolt® 2 Wedge Anchors (corresponds to length of anchor – inches)

Mark	Units	A	B	C	D	E	F	G	H	I	J	K	L	M	N	O	P	Q	R	S	T	U	V	W	X	Y	Z
From	in.	1 ½	2	2 ½	3	3 ½	4	4 ½	5	5 ½	6	6 ½	7	7 ½	8	8 ½	9	9 ½	10	11	12	13	14	15	16	17	18
Up To But Not Including	in.	2	2 ½	3	3 ½	4	4 ½	5	5 ½	6	6 ½	7	7 ½	8	8 ½	9	9 ½	10	11	12	13	14	15	16	17	18	19

Strong-Bolt® 2 Wedge Anchor

Strong-Bolt® 2 Anchor Product Data

Size (in.)	Carbon Steel Model No.	Type 304 Stainless Steel Model No.	Type 316 Stainless Steel Model No.	Drill Bit Dia. (in.)	Thread Length (in.)	Quantity	
						Box	Carton
¼ x 1¾	STB2-25134	STB2-251344SS	STB2-251346SS	¼	1 ⁵ / ₁₆	100	500
¼ x 2¼	STB2-25214	STB2-252144SS	STB2-252146SS	¼	1 ⁷ / ₁₆	100	500
¼ x 3¼	STB2-25314	STB2-253144SS	STB2-253146SS	¼	2 ⁷ / ₁₆	100	500
⅜ x 2¾	STB2-37234	—	STB2-372346SS	⅜	1 ⁵ / ₁₆	50	250
⅜ x 3	STB2-37300	—	STB2-373006SS	⅜	1 ⁹ / ₁₆	50	250
⅜ x 3½	STB2-37312	—	STB2-373126SS	⅜	2 ¹ / ₁₆	50	250
⅜ x 3¾	STB2-37334	—	STB2-373346SS	⅜	2 ⁵ / ₁₆	50	250
⅜ x 5	STB2-37500	—	STB2-375006SS	⅜	3 ⁹ / ₁₆	50	200
⅜ x 7	STB2-37700	—	STB2-377006SS	⅜	5 ⁹ / ₁₆	50	200
½ x 3¾	STB2-50334	—	STB2-503346SS	½	2 ¹ / ₁₆	25	125
½ x 4¾	STB2-50434	—	STB2-504346SS	½	3 ¹ / ₁₆	25	100
½ x 5½	STB2-50512	—	STB2-505126SS	½	3 ¹³ / ₁₆	25	100
½ x 7	STB2-50700	—	STB2-507006SS	½	5 ⁵ / ₁₆	25	100
½ x 8½	STB2-50812	—	STB2-508126SS	½	6	25	50
½ x 10	STB2-50100	—	STB2-501006SS	½	6	25	50
⅝ x 4½	STB2-62412	—	STB2-624126SS	⅝	2 ⁷ / ₁₆	20	80
⅝ x 5	STB2-62500	—	STB2-625006SS	⅝	2 ¹⁵ / ₁₆	20	80
⅝ x 6	STB2-62600	—	STB2-626006SS	⅝	3 ¹⁵ / ₁₆	20	80
⅝ x 7	STB2-62700	—	STB2-627006SS	⅝	4 ¹⁵ / ₁₆	20	80
⅝ x 8½	STB2-62812	—	STB2-628126SS	⅝	6	20	40
⅝ x 10	STB2-62100	—	STB2-621006SS	⅝	6	10	20
¾ x 5½	STB2-75512	—	STB2-755126SS	¾	3 ³ / ₁₆	10	40
¾ x 6¼	STB2-75614	—	STB2-756146SS	¾	3 ¹⁵ / ₁₆	10	40
¾ x 7	STB2-75700	—	STB2-757006SS	¾	4 ¹¹ / ₁₆	10	40
¾ x 8½	STB2-75812	—	STB2-758126SS	¾	6	10	20
¾ x 10	STB2-75100	—	—	¾	6	10	20
1 x 7	STB2-100700	—	—	1	3½	5	20
1 x 10	STB2-1001000	—	—	1	3½	5	10
1 x 13	STB2-1001300	—	—	1	3½	5	10

Installation:

 Do not use an impact wrench to set or tighten the Strong-Bolt 2 anchor

 **Caution:** Oversized holes in the base material will make it difficult to set the anchor and will reduce the anchor's load capacity.

1. Drill a hole in the base material using a carbide drill bit the same diameter as the nominal diameter of the anchor to be installed. Drill the hole to the specified minimum hole depth, and blow it clean using compressed air. (Overhead installations need not be blown clean.) Alternatively, drill the hole deep enough to accommodate embedment depth and dust from drilling.
2. Assemble the anchor with nut and washer so the top of the nut is flush with the top of the anchor. Place the anchor in the fixture, and drive it into the hole until the washer and nut are tight against the fixture.
3. Tighten to the required installation torque.

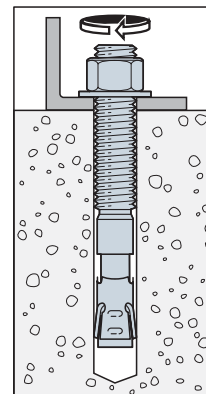
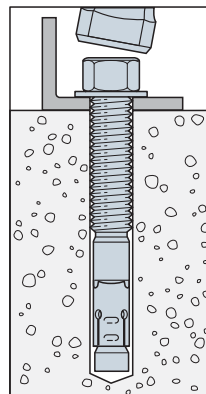
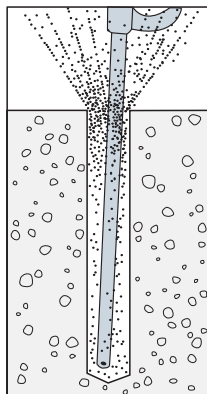
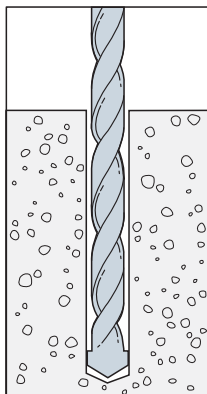
Installation Sequence:

Strong-Bolt® 2 Design Information — Concrete

Carbon Steel Strong-Bolt® 2 Installation Information¹

Characteristic	Symbol	Units	Nominal Anchor Diameter, d_a (in.)											
			¼ ⁴	⅜ ⁵		½ ⁵		⅝ ⁵		¾ ⁵		1 ⁵		
Installation Information														
Nominal Diameter	d_a	in.	¼	⅜		½		⅝		¾		1		
Drill Bit Diameter	d	in.	¼	⅜		½		⅝		¾		1		
Baseplate Clearance Hole Diameter ²	d_c	in.	5/16	7/16		9/16		11/16		7/8		1 1/8		
Installation Torque	T_{inst}	ft-lbf	4	30		60		90		150		230		
Nominal Embedment Depth	h_{nom}	in.	1 ¾	1 7/8	2 7/8	2 ¾	3 7/8	3 ¾	5 1/8	4 1/8	5 ¾	5 ¼	9 ¾	
Effective Embedment Depth	h_{ef}	in.	1 ½	1 ½	2 ½	2 ¼	3 ¾	2 ¾	4 ½	3 ¾	5	4 ½	9	
Minimum Hole Depth	h_{hole}	in.	1 7/8	2	3	3	4 1/8	3 5/8	5 3/8	4 3/8	6	5 ½	10	
Minimum Overall Anchor Length	ℓ_{anch}	in.	2 ¼	2 ¾	3 ½	3 ¾	5 ½	4 ½	6	5 ½	7	7	13	
Critical Edge Distance	c_{ac}	in.	2 ½	6 ½	6	6 ½	6 ½	7 ½	7 ½	9	9	8	18	13 ½
Minimum Edge Distance	c_{min}	in.	1 ¾	6		7	4	4	6 ½		6 ½		8	
	for $s \geq$	in.	—	—		—	—	—	—		8		—	
Minimum Spacing	s_{min}	in.	2 ¼	3		7	4	4	5		7		8	
	for $c \geq$	in.	—	—		—	—	—	—		—		—	
Minimum Concrete Thickness	h_{min}	in.	3 ¼	3 ¼	4 ½	4 ½	5 ½	6	5 ½	7 7/8	6 ¾	8 ¾	9	13 ½
Additional Data														
Yield Strength	f_{ya}	psi	56,000		92,000		85,000				70,000		60,000	
Tensile Strength	f_{uta}	psi	70,000		115,000						110,000		78,000	
Minimum Tensile and Shear Stress Area	A_{se}	in. ²	0.0318		0.0514		0.105		0.166		0.270		0.472	
Axial Stiffness in Service Load Range — Cracked and Uncracked Concrete	β	lb./in.	73,700 ³		34,820		63,570		91,370		118,840		299,600	

1. The information presented in this table is to be used in conjunction with the design criteria of ACI 318 Appendix D.

2. The clearance must comply with applicable code requirements for the connected element.

3. The tabulated value of β for ¼-inch diameter carbon steel Strong-Bolt 2 anchor is for installations in uncracked concrete only.

4. The ¼-inch-diameter (6.4mm) anchor may be installed in top of uncracked normal-weight and sand-lightweight concrete over profile steel deck, where concrete thickness above upper flute meets the minimum thickness specified in this table.

5. The ⅜-inch-through 1-inch-diameter (9.5mm through 25.4mm) anchors may be installed in top of cracked and uncracked normal-weight and sand-lightweight concrete over profile steel deck, where concrete thickness above upper flute meets the minimum thickness specified in this table.

Strong-Bolt® 2 Design Information — Concrete

Stainless-Steel Strong-Bolt® 2 Installation Information¹

Characteristic	Symbol	Units	Nominal Anchor Diameter, d_a (in.)									
			$\frac{1}{4}$ ⁴		$\frac{3}{8}$ ⁵		$\frac{1}{2}$ ⁵		$\frac{5}{8}$ ⁵		$\frac{3}{4}$ ⁵	
Installation Information												
Nominal Diameter	d_a	in.	$\frac{1}{4}$		$\frac{3}{8}$		$\frac{1}{2}$		$\frac{5}{8}$		$\frac{3}{4}$	
Drill Bit Diameter	d	in.	$\frac{1}{4}$		$\frac{3}{8}$		$\frac{1}{2}$		$\frac{5}{8}$		$\frac{3}{4}$	
Baseplate Clearance Hole Diameter ²	d_c	in.	$\frac{5}{16}$		$\frac{7}{16}$		$\frac{9}{16}$		$\frac{11}{16}$		$\frac{7}{8}$	
Installation Torque	T_{inst}	ft-lbf	4		30		60		80		150	
Nominal Embedment Depth	h_{nom}	in.	$1\frac{3}{4}$		$1\frac{7}{8}$ $2\frac{7}{8}$		$2\frac{3}{4}$ $3\frac{7}{8}$		$3\frac{3}{8}$ $5\frac{1}{8}$		$4\frac{1}{8}$ $5\frac{3}{4}$	
Effective Embedment Depth	h_{ef}	in.	$1\frac{1}{2}$		$1\frac{1}{2}$ $2\frac{1}{2}$		$2\frac{1}{4}$ $3\frac{3}{8}$		$2\frac{3}{4}$ $4\frac{1}{2}$		$3\frac{3}{8}$ 5	
Minimum Hole Depth	h_{hole}	in.	$1\frac{7}{8}$		2 3		3 $4\frac{1}{8}$		$3\frac{5}{8}$ $5\frac{3}{8}$		$4\frac{3}{8}$ 6	
Minimum Overall Anchor Length	ℓ_{anch}	in.	$2\frac{1}{4}$		$2\frac{3}{4}$ $3\frac{1}{2}$		$3\frac{3}{4}$ $5\frac{1}{2}$		$4\frac{1}{2}$ 6		$5\frac{1}{2}$ 7	
Critical Edge Distance	c_{ac}	in.	$2\frac{1}{2}$		$6\frac{1}{2}$ $8\frac{1}{2}$		$4\frac{1}{2}$ 7		$7\frac{1}{2}$ 9		8 8	
Minimum Edge Distance	c_{min}	in.	$1\frac{3}{4}$		6		$6\frac{1}{2}$ 5 4		4		6	
	for $s \geq$	in.	—		10		— — 8		8		—	
Minimum Spacing	s_{min}	in.	$2\frac{1}{4}$		3		8 $5\frac{1}{2}$ 4		$6\frac{1}{4}$		$6\frac{1}{2}$	
	for $c \geq$	in.	—		10		— 8		$5\frac{1}{2}$		—	
Minimum Concrete Thickness	h_{min}	in.	$3\frac{1}{4}$		$3\frac{1}{4}$ $4\frac{1}{2}$		$4\frac{1}{2}$ 6		$5\frac{1}{2}$ $7\frac{7}{8}$		$6\frac{3}{4}$ $8\frac{3}{4}$	
Additional Data												
Yield Strength	f_{ya}	psi	96,000		80,000		92,000		82,000		68,000	
Tensile Strength	f_{uta}	psi	120,000		100,000		115,000		108,000		95,000	
Minimum Tensile and Shear Stress Area	A_{se}	in. ²	0.0255		0.0514		0.105		0.166		0.270	
Axial Stiffness in Service Load Range — Cracked and Uncracked Concrete	β	lb./in.	54,430 ³		29,150		54,900		61,270		154,290	

1. The information presented in this table is to be used in conjunction with the design criteria of ACI 318 Appendix D.

2. The clearance must comply with applicable code requirements for the connected element.

3. The tabulated value of β for $\frac{1}{4}$ -inch diameter stainless steel Strong-Bolt 2 anchor is for installations in uncracked concrete only.

4. The $\frac{1}{4}$ -inch-diameter (6.4mm) anchor may be installed in top of uncracked normal-weight and sand-lightweight concrete over profile steel deck, where concrete thickness above upper flute meets the minimum thickness specified in this table.

5. The $\frac{3}{8}$ -inch-through $\frac{3}{4}$ -inch-diameter (9.5mm through 19.1mm) anchors may be installed in top of cracked and uncracked normal-weight and sand-lightweight concrete over profile steel deck, where concrete thickness above upper flute meets the minimum thickness specified in this table.

Strong-Bolt® 2 Design Information — Concrete

Carbon Steel Strong-Bolt® 2 Tension Strength Design Data¹

Characteristic	Symbol	Units	Nominal Anchor Diameter, d_a (in.)										
			$\frac{1}{4}^8$	$\frac{3}{8}^9$	$\frac{1}{2}^9$	$\frac{5}{8}^9$	$\frac{3}{4}^9$	1^9					
Anchor Category	1, 2 or 3	—	1										2
Nominal Embedment Depth	h_{nom}	in.	$1\frac{1}{4}$	$1\frac{1}{8}$	$2\frac{1}{8}$	$2\frac{1}{4}$	$3\frac{1}{8}$	$3\frac{1}{2}$	$4\frac{1}{8}$	$4\frac{1}{2}$	$5\frac{1}{4}$	$5\frac{1}{2}$	$6\frac{1}{4}$
Steel Strength in Tension (ACI 318 Section D.5.1)													
Steel Strength in Tension	N_{sa}	lb.	2,225	5,600	12,100	19,070	29,700	36,815					
Strength Reduction Factor — Steel Failure ²	ϕ_{sa}	—	0.75										0.65
Concrete Breakout Strength in Tension (ACI 318 Section D.5.2)¹⁰													
Effective Embedment Depth	h_{ef}	in.	$1\frac{1}{2}$	$1\frac{1}{2}$	$2\frac{1}{2}$	$2\frac{1}{4}$	$3\frac{3}{8}$	$2\frac{3}{4}$	$4\frac{1}{2}$	$3\frac{3}{4}$	5	$4\frac{1}{2}$	9
Critical Edge Distance	c_{ac}	in.	$2\frac{1}{2}$	$6\frac{1}{2}$	6	$6\frac{1}{2}$	$7\frac{1}{2}$	$7\frac{1}{2}$	9	9	8	18	$13\frac{1}{2}$
Effectiveness Factor — Uncracked Concrete	k_{uncr}	—	24										
Effectiveness Factor — Cracked Concrete	k_{cr}	—	— ⁷										
Modification Factor	$\psi_{c,N}$	—	— ⁷										
Strength Reduction Factor — Concrete Breakout Failure ³	ϕ_{cb}	—	0.65										0.55
Pullout Strength in Tension (ACI 318 Section D.5.3)¹⁰													
Pullout Strength, Cracked Concrete ($f'_c=2,500$ psi)	$N_{p,cr}$	lb.	— ⁷	1,300 ⁵	2,775 ⁵	N/A ⁴	3,735 ⁵	N/A ⁴	6,985 ⁵	N/A ⁴	8,500 ⁵	7,700 ⁵	11,185 ⁵
Pullout Strength, Uncracked Concrete ($f'_c=2,500$ psi)	$N_{p,uncr}$	lb.	N/A ⁴	N/A ⁴	3,340 ⁵	3,615 ⁵	5,255 ⁵	N/A ⁴	9,025 ⁵	7,115 ⁵	8,870 ⁵	8,360 ⁵	9,690 ⁵
Strength Reduction Factor — Pullout Failure ⁶	ϕ_p	—	0.65										0.55
Tensile Strength for Seismic Applications (ACI 318 Section D.3.3.)¹⁰													
Tension Strength of Single Anchor for Seismic Loads ($f'_c=2,500$ psi)	$N_{p,eq}$	lb.	— ⁷	1,300 ⁵	2,775 ⁵	N/A ⁴	3,735 ⁵	N/A ⁴	6,985 ⁵	N/A ⁴	8,500 ⁵	7,700 ⁵	11,185 ⁵
Strength Reduction Factor — Pullout Failure ⁶	ϕ_{eq}	—	0.65										0.55

- The information presented in this table must be used in conjunction with the design criteria of ACI 318 Appendix D, except as modified below.
- The tabulated value of ϕ_{sa} applies when the load combinations of Section 1605.2.1 of the IBC or ACI 318 Section 9.2 are used. If the load combinations of ACI 318 Appendix C are used, the appropriate value of ϕ_{sa} must be determined in accordance with ACI 318 D.4.4. Strong-Bolt 2 anchors are ductile steel elements as defined in ACI 318 D.1.
- The tabulated value of ϕ_{cb} applies when both the load combinations of Section 1605.2.1 of the IBC or ACI 318 Section 9.2 are used and the requirements of ACI 318 D.4.3(c) for Condition B are met. Condition B applies where supplementary reinforcement is not provided. For installations where complying supplementary reinforcement can be verified, the ϕ_{cb} factors described in ACI 318 D.4.3 for Condition A are allowed. If the load combinations of ACI 318 Section 9.2 are used and the requirements of ACI 318 Section D.4.3 for Condition A are met, the appropriate value of ϕ_{cb} must be determined in accordance with ACI 318 D.4.3(c). If the load combinations of ACI 318 Appendix C are used, the appropriate value of ϕ_{cb} must be determined in accordance with ACI 318 D.4.4(c).
- N/A (not applicable) denotes that pullout resistance does not need to be considered.
- The characteristic pullout strength for greater concrete compressive strengths shall be increased by multiplying the tabular value by $(f'_c/2,500 \text{ psi})^{0.5}$.
- The tabulated value of ϕ_p or ϕ_{eq} applies when the load combinations of Section 1605.2.1 of the IBC or ACI 318 Section 9.2 are used and the requirements of ACI 318 D.4.3(c) for Condition B are met. If the load combinations of ACI 318 Appendix C are used, appropriate value of ϕ must be determined in accordance with ACI 318 Section D.4.4(c).
- The $\frac{1}{4}$ -inch diameter carbon steel Strong-Bolt 2 anchor installation in cracked concrete is beyond the scope of this report.
- The $\frac{1}{4}$ -inch diameter (6.4mm) anchor may be installed in top of uncracked normal-weight and sand-lightweight concrete over profile steel deck, where concrete thickness above upper flute meets the minimum thickness specified in the table on page 146.
- The $\frac{3}{8}$ -inch through 1-inch diameter (9.5mm through 25.4mm) anchors may be installed in top of cracked and uncracked normal-weight and sand-lightweight concrete over profile steel deck, where concrete thickness above upper flute meets the minimum thickness specified in the table on page 146.
- For sand-lightweight concrete, in lieu of ACI 318 Section D.3.6, modify the value of concrete breakout strength $N_{p,cr}$, $N_{p,uncr}$ and N_{eq} by 0.6. All-lightweight concrete is beyond the scope of this table.

* See page 12 for an explanation of the load table icons.

Strong-Bolt® 2 Design Information — Concrete

Stainless-Steel Strong-Bolt® 2 Tension Strength Design Data¹

Characteristic	Symbol	Units	Nominal Anchor Diameter, d_a (in.)								
			1/4" ¹⁰	3/8" ¹¹	1/2"	5/8"	3/4"	1"	1 1/8"	1 1/4"	1 1/2"
Anchor Category	1, 2 or 3	—	1								
Nominal Embedment Depth	h_{nom}	in.	1 3/4	1 7/8	2 1/8	2 3/8	2 7/8	3 1/8	3 5/8	4 1/8	4 5/8
Steel Strength in Tension (ACI 318 Section D.5.1)											
Steel Strength in Tension	N_{sa}	lb.	3,060	5,140	12,075	17,930	25,650				
Strength Reduction Factor — Steel Failure ²	ϕ_{sa}	—	0.75								
Concrete Breakout Strength in Tension (ACI 318 Section D.5.2)¹²											
Effective Embedment Depth	h_{ef}	in.	1 1/2	1 1/2	2 1/2	2 1/4	3 3/8	2 3/4	4 1/2	3 3/8	5
Critical Edge Distance	c_{ac}	in.	2 1/2	6 1/2	8 1/2	4 1/2	7	7 1/2	9	8	8
Effectiveness Factor — Uncracked Concrete	k_{uncr}	—	24								
Effectiveness Factor — Cracked Concrete	k_{cr}	—	17								
Modification Factor	$\psi_{c,N}$	—	1.00								
Strength Reduction Factor — Concrete Breakout Failure ³	ϕ_{cb}	—	0.65								
Pullout Strength in Tension (ACI 318 Section D.5.3)¹²											
Pullout Strength, Cracked Concrete ($f'_c=2,500$ psi)	$N_{p,cr}$	lb.	— ⁹	1,720 ⁶	3,145 ⁶	2,560 ⁵	4,305 ⁵	N/A ⁴	6,545 ⁷	N/A ⁴	8,230 ⁵
Pullout Strength, Uncracked Concrete ($f'_c=2,500$ psi)	$N_{p,uncr}$	lb.	1,925 ⁷	N/A ⁴	4,770 ⁶	3,230 ⁵	4,495 ⁵	N/A ⁴	7,615 ⁷	7,725 ⁷	9,625 ⁷
Strength Reduction Factor — Pullout Failure ⁸	ϕ_p	—	0.65								
Tensile Strength for Seismic Applications (ACI 318 Section D.3.3.)¹²											
Tension Strength of Single Anchor for Seismic Loads ($f'_c=2,500$ psi)	$N_{p,eq}$	lb.	— ⁹	1,720 ⁶	2,830 ⁶	2,560 ⁵	4,305 ⁵	N/A ⁴	6,545 ⁷	N/A ⁴	8,230 ⁵
Strength Reduction Factor — Pullout Failure ⁸	ϕ_{eq}	—	0.65								

- The information presented in this table must be used in conjunction with the design criteria of ACI 318 Appendix D, except as modified below.
- The tabulated value of ϕ_{sa} applies when the load combinations of Section 1605.2.1 of the IBC or ACI 318 Section 9.2 are used, if the load combinations of ACI 318 Appendix C are used, the appropriate value of ϕ_{sa} must be determined in accordance with ACI 318 D.4.4. Strong-Bolt 2 anchors are ductile steel elements as defined in ACI 318 D.1.
- The tabulated value of ϕ_{cb} applies when both the load combinations of Section 1605.2.1 of the IBC or ACI 318 Section 9.2 are used and the requirements of ACI 318 D.4.3(c) for Condition B are met. Condition B applies where supplementary reinforcement is not provided. For installations where complying supplementary reinforcement can be verified, the ϕ_{cb} factors described in ACI 318 D.4.3 for Condition A are allowed. If the load combinations of ACI 318 Section 9.2 are used and the requirements of ACI 318 Section D.4.3 for Condition A are met, the appropriate value of ϕ_{cb} must be determined in accordance with ACI 318 D.4.3(c). If the load combinations of ACI 318 Appendix C are used, the appropriate value of ϕ_{cb} must be determined in accordance with ACI 318 D.4.4(c).
- N/A (not applicable) denotes that pullout resistance does not need to be considered.
- The characteristic pullout strength for greater concrete compressive strengths shall be increased by multiplying the tabular value by $(f'_c/2,500 \text{ psi})^{0.5}$.
- The characteristic pullout strength for greater concrete compressive strengths shall be increased by multiplying the tabular value by $(f'_c/2,500 \text{ psi})^{0.3}$.
- The characteristic pullout strength for greater concrete compressive strengths shall be increased by multiplying the tabular value by $(f'_c/2,500 \text{ psi})^{0.4}$.
- The tabulated value of ϕ_p or ϕ_{eq} applies when the load combinations of Section 1605.2.1 of the IBC or ACI 318 Section 9.2 are used and the requirements of ACI 318 D.4.3(c) for Condition B are met. If the load combinations of ACI 318 Appendix C are used, appropriate value of ϕ must be determined in accordance with ACI 318 Section D.4.4(c).
- The 1/4-inch diameter stainless steel Strong-Bolt 2 anchor installation in cracked concrete is beyond the scope of this report.
- The 1/4-inch diameter (6.4mm) anchor may be installed in top of uncracked normal-weight and sand-lightweight concrete over profile steel deck, where concrete thickness above upper flute meets the minimum thickness specified in the table on page 147.
- The 3/8-inch through 3/4-inch diameter (9.5mm through 19.1mm) anchors may be installed in top of cracked and uncracked normal-weight and sand-lightweight concrete over profile steel deck, where concrete thickness above upper flute meets the minimum thickness specified in the table on page 147.
- For sand-lightweight concrete, in lieu of ACI 318 Section D.3.6, modify the value of concrete breakout strength $N_{p,cr}$, $N_{p,uncr}$ and N_{eq} by 0.6. All-lightweight concrete is beyond the scope of this table.

* See page 12 for an explanation of the load table icons.

Strong-Bolt® 2 Design Information — Concrete

Carbon Steel Strong-Bolt® 2 Shear Strength Design Data¹

Characteristic	Symbol	Units	Nominal Anchor Diameter, d_a (in.)										
			$\frac{1}{4}^6$	$\frac{3}{8}^7$	$\frac{1}{2}^7$	$\frac{5}{8}^7$	$\frac{3}{4}^7$	1^7					
Anchor Category	1, 2 or 3	—	1									2	
Nominal Embedment Depth	h_{nom}	in.	1 $\frac{3}{4}$	1 $\frac{7}{8}$	2 $\frac{7}{8}$	2 $\frac{3}{4}$	3 $\frac{7}{8}$	3 $\frac{3}{8}$	5 $\frac{1}{8}$	4 $\frac{1}{8}$	5 $\frac{3}{4}$	5 $\frac{1}{4}$	9 $\frac{3}{4}$
Steel Strength in Shear (ACI 318 Section D.6.1)													
Steel Strength in Shear	V_{sa}	lb.	965	1,800	7,235	11,035	14,480	15,020					
Strength Reduction Factor — Steel Failure ²	ϕ_{sa}	—	0.65									0.60	
Concrete Breakout Strength in Shear (ACI 318 Section D.6.2)⁸													
Outside Diameter	d_a	in.	0.25	0.375	0.500	0.625	0.750	1.00					
Load-Bearing Length of Anchor in Shear	ℓ_e	in.	1.500	1.500	2.500	2.250	3.375	2.750	4.500	3.375	5.000	4.500	8.000
Strength Reduction Factor — Concrete Breakout Failure ²	ϕ_{cb}	—	0.70										
Concrete Pryout Strength in Shear (ACI 318 Section D.6.3)													
Coefficient for Pryout Strength	k_{cp}	—	1.0	2.0	1.0	2.0							
Effective Embedment Depth	h_{ef}	in.	1 $\frac{1}{2}$	1 $\frac{1}{2}$	2 $\frac{1}{2}$	2 $\frac{1}{4}$	3 $\frac{3}{8}$	2 $\frac{3}{4}$	4 $\frac{1}{2}$	3 $\frac{3}{8}$	5	4 $\frac{1}{2}$	9
Strength Reduction Factor — Concrete Pryout Failure ⁴	ϕ_{cp}	—	0.70										
Steel Strength in Shear for Seismic Applications(ACI 318 Section D.3.3.)													
Shear Strength of Single Anchor for Seismic Loads ($f'_c=2,500$ psi)	$V_{sa,eq}$	lb.	— ⁵	1,800	6,510	9,930	11,775	15,020					
Strength Reduction Factor — Steel Failure ²	ϕ_{sa}	—	0.65									0.60	

- The information presented in this table must be used in conjunction with the design criteria of ACI 318 Appendix D, except as modified below.
- The tabulated value of ϕ_{sa} applies when the load combinations of Section 1605.2.1 of the IBC or ACI 318 Section 9.2 are used and the requirements of ACI 318 D.4.3(c) for Condition B are met. If the load combinations of ACI 318 Appendix C are used, the appropriate value of ϕ_{sa} must be determined in accordance with ACI 318 D.4.4. Strong-Bolt 2 anchors are ductile steel elements as defined in ACI 318 D.1.
- The tabulated value of ϕ_{cb} applies when both the load combinations of Section 1605.2.1 of the IBC or ACI 318 Section 9.2 are used and the requirements of ACI 318 D.4.3(c) for Condition B are met. Condition B applies where supplementary reinforcement is not provided. For installations where complying supplementary reinforcement can be verified, the ϕ_{cb} factors described in ACI 318 D.4.3 for Condition A are allowed. If the load combinations of ACI 318 Section 9.2 are used and the requirements of ACI 318 Section D.4.3 for Condition A are met, the appropriate value of ϕ_{cb} must be determined in accordance with ACI 318 D.4.3(c). If the load combinations of ACI 318 Appendix C are used, the appropriate value of ϕ_{cb} must be determined in accordance with ACI 318 D.4.4(c).
- The tabulated value of ϕ_{cp} applies when both the load combinations of ACI 318 Section 9.2 are used and the requirements of ACI 318 D.4.3(c) for Condition B are met. If the load combinations of ACI 318 Appendix C are used, appropriate value of ϕ_{cp} must be determined in accordance with ACI 318 Section D.4.4(c).
- The $\frac{1}{4}$ -inch diameter carbon steel Strong-Bolt 2 anchor installation in cracked concrete is beyond the scope of this report.
- The $\frac{1}{4}$ -inch diameter (6.4mm) anchor may be installed in top of uncracked normal-weight and sand-lightweight concrete over profile steel deck, where concrete thickness above upper flute meets the minimum thickness specified in the table on page 146.
- The $\frac{3}{8}$ -inch through 1-inch diameter (9.5mm through 25.4mm) anchors may be installed in top of cracked and uncracked normal-weight and sand-lightweight concrete over profile steel deck, where concrete thickness above upper flute meets the minimum thickness specified in the table on page 146.
- For sand-lightweight concrete, in lieu of ACI 318 Section D.3.6, modify the value of concrete breakout by 0.6. All-lightweight concrete is beyond the scope of this table.

* See page 12 for an explanation of the load table icons.

Strong-Bolt® 2 Design Information — Concrete

Stainless-Steel Strong-Bolt® 2 Shear Strength Design Data¹

Characteristic	Symbol	Units	Nominal Anchor Diameter, d_a (in.)									
			$\frac{1}{4}$ ⁶	$\frac{3}{8}$ ⁷	$\frac{1}{2}$ ⁷	$\frac{5}{8}$ ⁷	$\frac{3}{4}$ ⁷	$\frac{7}{8}$ ⁷	1 ⁷	$1\frac{1}{8}$ ⁷	$1\frac{1}{4}$ ⁷	$1\frac{3}{8}$ ⁷
Anchor Category	1, 2 or 3	—	1									
Nominal Embedment Depth	h_{nom}	in.	1 $\frac{3}{4}$	1 $\frac{7}{8}$	2 $\frac{7}{8}$	2 $\frac{3}{4}$	3 $\frac{7}{8}$	3 $\frac{3}{8}$	5 $\frac{1}{8}$	4 $\frac{1}{8}$	5 $\frac{1}{4}$	5 $\frac{3}{4}$
Steel Strength in Shear (ACI 318 Section D.6.1)												
Steel Strength in Shear	V_{sa}	lb.	1,605	3,085	7,245	6,745	10,760	15,045				
Strength Reduction Factor — Steel Failure ²	ϕ_{sa}	—	0.65									
Concrete Breakout Strength in Shear (ACI 318 Section D.6.2)⁸												
Outside Diameter	d_a	in.	0.250	0.375	0.500	0.625	0.750					
Load Bearing Length of Anchor in Shear	ℓ_e	in.	1.500	1.500	2.500	2.250	3.375	2.750	4.500	3.375	5.000	
Strength Reduction Factor — Concrete Breakout Failure ³	ϕ_{cb}	—	0.70									
Concrete Pryout Strength in Shear (ACI 318 Section D.6.3)												
Coefficient for Pryout Strength	k_{cp}	—	1.0	2.0	1.0	2.0						
Effective Embedment Depth	h_{ef}	in.	1 $\frac{1}{2}$	1 $\frac{1}{2}$	2 $\frac{1}{2}$	2 $\frac{1}{4}$	3 $\frac{3}{8}$	2 $\frac{3}{4}$	4 $\frac{1}{2}$	3 $\frac{3}{8}$	5	
Strength Reduction Factor — Concrete Pryout Failure ⁴	ϕ_{cp}	—	0.70									
Steel Strength in Shear for Seismic Applications (ACI 318 Section D.3.3.)												
Shear Strength of Single Anchor for Seismic Loads ($f'_c=2,500$ psi)	$V_{sa,eq}$	lb.	— ⁵	3,085	6,100	6,745	10,760	13,620				
Strength Reduction Factor — Steel Failure ²	ϕ_{sa}	—	0.65									

- The information presented in this table must be used in conjunction with the design criteria of ACI 318 Appendix D, except as modified below.
- The tabulated value of ϕ_{sa} applies when the load combinations of Section 1605.2.1 of the IBC or ACI 318 Section 9.2 are used and the requirements of ACI 318 D.4.3(c) Condition B are met. If the load combinations of ACI 318 Appendix C are used, the appropriate value of ϕ_{sa} must be determined in accordance with ACI 318 D.4.3.(c) for Strong-Bolt 2 anchors are ductile steel elements as defined in ACI 318 D.1.
- The tabulated value of ϕ_{cb} applies when both the load combinations of Section 1605.2.1 of the IBC or ACI 318 Section 9.2 are used and the requirements of ACI 318 D.4.3(c) for Condition B are met. Condition B applies where supplementary reinforcement is not provided. For installations where complying supplementary reinforcement can be verified, the ϕ_{cb} factors described in ACI 318 D.4.3 for Condition A are allowed. If the load combinations of ACI 318 Section 9.2 are used and the requirements of ACI 318 Section D.4.3 for Condition A are met, the appropriate value of ϕ_{cb} must be determined in accordance with ACI 318 D.4.3.(c). If the load combinations of ACI 318 Appendix C are used, the appropriate value of ϕ_{cb} must be determined in accordance with ACI 318 D.4.4.(c).
- The tabulated value of ϕ_{cp} applies when both the load combinations of ACI 318 Section 9.2 are used and the requirements of ACI 318 D.4.3(c) for Condition B are met. If the load combinations of ACI 318 Appendix C are used, appropriate value of ϕ_{cp} must be determined in accordance with ACI 318 Section D.4.4.(c).
- The $\frac{1}{4}$ -inch diameter stainless-steel Strong-Bolt 2 anchor installation in cracked concrete is beyond the scope of this report.
- The $\frac{1}{4}$ -inch diameter (6.4mm) anchor may be installed in top of uncracked normal-weight and sand-lightweight concrete over profile steel deck, where concrete thickness above upper flute meets the minimum thickness specified in the table on page 147.
- The $\frac{3}{8}$ -inch through $\frac{3}{4}$ -inch diameter (9.5mm through 19.1mm) anchors may be installed in top of cracked and uncracked normal-weight and sand-lightweight concrete over profile steel deck, where concrete thickness above upper flute meets the minimum thickness specified in the table on page 147.
- For sand-lightweight concrete, in lieu of ACI 318 Section D.3.6, modify the value of concrete breakout by 0.6. All-lightweight concrete is beyond the scope of this table.

* See page 12 for an explanation of the load table icons.

Strong-Bolt® 2 Design Information — Concrete

Carbon Steel Strong-Bolt® 2 Information for Installation in the Topside of Concrete-Filled Profile Steel Deck Floor and Roof Assemblies^{1,2,3,4}



Design Information	Symbol	Units	Nominal Anchor Diameter (in.)	
			3/8	1/2
Nominal Embedment Depth	h_{nom}	in.	1 7/8	2 3/4
Effective Embedment Depth	h_{ef}	in.	1 1/2	2 1/4
Minimum Concrete Thickness ⁵	$h_{min,deck}$	in.	2 1/2	3 1/4
Critical Edge Distance	$c_{ac,deck,top}$	in.	4 3/4	4
Minimum Edge Distance	$c_{min,deck,top}$	in.	4 3/4	4 1/2
Minimum Spacing	$s_{min,deck,top}$	in.	7	6 1/2

For SI: 1 inch = 25.4mm; 1 lbf = 4.45N

1. Installation must comply with the table on page 146 and Figure 1 below.
2. Design capacity shall be based on calculations according to values in the tables on pages 148 and 150.
3. Minimum flute depth (distance from top of flute to bottom of flute) is 1 1/2 inches.
4. Steel deck thickness shall be a minimum 20 gauge.
5. Minimum concrete thickness ($h_{min,deck}$) refers to concrete thickness above upper flute.

Stainless-Steel Strong-Bolt® 2 Information for Installation in the Topside of Concrete-Filled Profile Steel Deck Floor and Roof Assemblies^{1,2,3,4}



Design Information	Symbol	Units	Nominal Anchor Diameter (in.)	
			3/8	1/2
Nominal Embedment Depth	h_{nom}	in.	1 7/8	2 3/4
Effective Embedment Depth	h_{ef}	in.	1 1/2	2 1/4
Minimum Concrete Thickness ⁵	$h_{min,deck}$	in.	2 1/2	3 1/4
Critical Edge Distance	$c_{ac,deck,top}$	in.	4 3/4	4
Minimum Edge Distance	$c_{min,deck,top}$	in.	4 3/4	6
Minimum Spacing	$s_{min,deck,top}$	in.	6 1/2	8

For SI: 1 inch = 25.4mm; 1 lbf = 4.45N

1. Installation must comply with the table on page 147 and Figure 1 below.
2. Design capacity shall be based on calculations according to values in the tables on pages 149 and 151.
3. Minimum flute depth (distance from top of flute to bottom of flute) is 1 1/2 inches.
4. Steel deck thickness shall be a minimum 20 gauge.
5. Minimum concrete thickness ($h_{min,deck}$) refers to concrete thickness above upper flute.

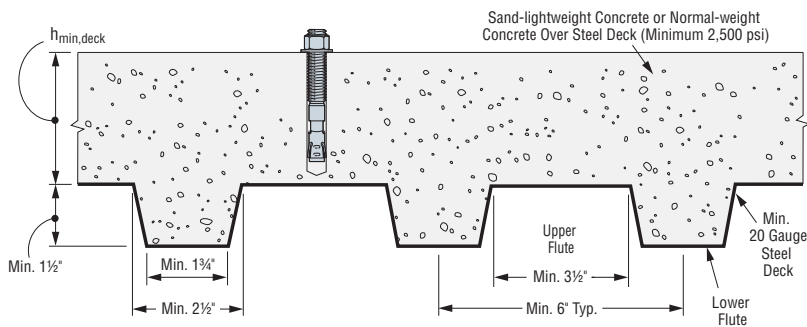

Figure 1

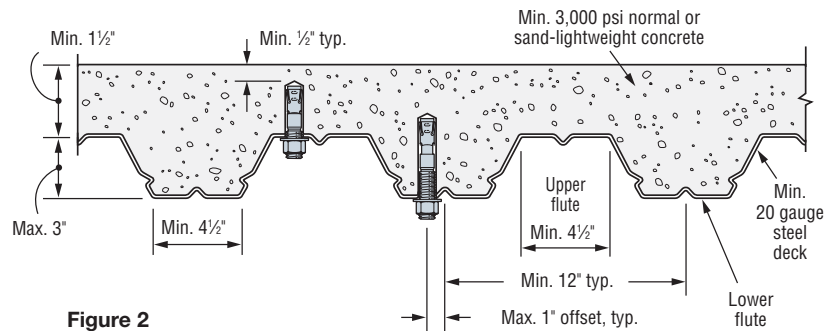

Figure 2

* See page 12 for an explanation of the load table icons.

Strong-Bolt® 2 Design Information — Concrete

Carbon Steel Strong-Bolt® 2 Tension and Shear Strength Design
Data for the Soffit of Concrete over Profile Steel Deck Floor and Roof Assemblies^{1,2,6,8,9}



Characteristic	Symbol	Units	Nominal Anchor Diameter (in.)								
			Carbon Steel								
			Lower Flute					Upper Flute			
			3/8	1/2	5/8	3/4	3/8	1/2			
Nominal Embedment Depth	h_{nom}	in.	2	3 3/8	2 3/4	4 1/2	3 3/8	5 5/8	4 1/8	2	2 3/4
Effective Embedment Depth	h_{ef}	in.	1 5/8	3	2 1/4	4	2 3/4	5	3 3/8	1 5/8	2 1/4
Installation Torque	T_{inst}	ft.-lbf.	30		60		90		150	30	60
Pullout Strength, concrete on metal deck (cracked) ^{3,4}	$N_{p,deck,cr}$	lb.	1,040 ⁷	2,615 ⁷	2,040 ⁷	2,730 ⁷	2,615 ⁷	4,990 ⁷	2,815 ⁷	1,340 ⁷	3,785 ⁷
Pullout Strength, concrete on metal deck (uncracked) ^{3,4}	$N_{p,deck,uncr}$	lb.	1,765 ⁷	3,150 ⁷	2,580 ⁷	3,840 ⁷	3,685 ⁷	6,565 ⁷	3,800 ⁷	2,275 ⁷	4,795 ⁷
Pullout Strength, concrete on metal deck (seismic) ^{3,4}	$N_{p,deck,eq}$	lb.	1,040 ⁷	2,615 ⁷	2,040 ⁷	2,730 ⁷	2,615 ⁷	4,990 ⁷	2,815 ⁷	1,340 ⁷	3,785 ⁷
Steel Strength in Shear, concrete on metal deck ⁵	$V_{sa,deck}$	lb.	1,595	3,490	2,135	4,580	2,640	7,000	4,535	3,545	5,920
Steel Strength in Shear, concrete on metal deck (seismic) ⁵	$V_{sa,deck,eq}$	lb.	1,595	3,490	1,920	4,120	2,375	6,300	3,690	3,545	5,330

- The information presented in this table must be used in conjunction with the design criteria of ACI 318 Appendix D, except as modified below.
- Profile steel deck must comply with the configuration in Figure 2 on the previous page, and have a minimum base-steel thickness of 0.035 inch [20 gauge]. Steel must comply with ASTM A 653/A 653M SS Grade 33 with minimum yield strength of 33,000 psi. Concrete compressive strength shall be 3,000 psi minimum.
- For anchors installed in the soffit of sand-lightweight or normal-weight concrete over metal deck floor and roof assemblies, calculation of the concrete breakout strength may be omitted.
- In accordance with ACI 318 Section D.5.3.2, the nominal pullout strength in cracked concrete for anchors installed in the soffit of sand-lightweight or normal-weight concrete over metal deck floor and roof assemblies $N_{p,deck,cr}$ shall be substituted for $N_{p,cr}$. Where analysis indicates no cracking at service loads, the normal pullout strength in uncracked concrete $N_{p,deck,uncr}$ shall be substituted for $N_{p,uncr}$. For seismic loads, $N_{p,deck,eq}$ shall be substituted for $N_{p,cr}$.
- In accordance with ACI 318 Section D.6.1.2(c), the shear strength for anchors installed in the soffit of sand-lightweight or normal-weight concrete over metal deck floor and roof assemblies $V_{sa,deck}$ shall be substituted for V_{sa} . For seismic loads, $V_{sa,deck,eq}$ shall be substituted for V_{sa} .
- The minimum anchor spacing along the flute must be the greater of $3.0h_{ef}$ or 1.5 times the flute width.
- The characteristic pull-out strength for greater concrete compressive strengths shall be increased by multiplying the tabular value by $(f'_c / 3,000 \text{ psi})^{0.5}$.
- Concrete shall be normal-weight or structural sand-lightweight concrete having a minimum specified compressive strength, f'_c , of 3,000 psi.
- Minimum distance to edge of panel is $2h_{ef}$.

Mechanical Anchors

Stainless Steel Strong-Bolt® 2 Tension and Shear Strength Design Data
for the Soffit of Concrete over Profile Steel Deck Floor and Roof Assemblies^{1,2,6,10,11}



Characteristic	Symbol	Units	Stainless Steel								
			Lower Flute								
			Lower Flute					Upper Flute			
			3/8	1/2	5/8	3/4	3/8	1/2			
Nominal Embedment Depth	h_{nom}	in.	2	3 3/8	2 3/4	4 1/2	3 3/8	5 5/8	4 1/8	2	2 3/4
Effective Embedment Depth	h_{ef}	in.	1 5/8	3	2 1/4	4	2 3/4	5	3 3/8	1 5/8	2 1/4
Installation Torque	T_{inst}	ft.-lbf.	30		60		80		150	30	60
Pullout Strength, concrete on metal deck (cracked) ³	$N_{p,deck,cr}$	lb.	1,230 ⁸	2,605 ⁸	1,990 ⁷	2,550 ⁷	1,750 ⁹	4,020 ⁹	3,030 ⁷	1,550 ⁸	2,055 ⁷
Pullout Strength, concrete on metal deck (uncracked) ³	$N_{p,deck,uncr}$	lb.	1,580 ⁸	3,950 ⁸	2,475 ⁷	2,660 ⁷	2,470 ⁷	5,000 ⁷	4,275 ⁹	1,990 ⁸	2,560 ⁷
Pullout Strength, concrete on metal deck (seismic) ⁵	$N_{p,deck,eq}$	lb.	1,230 ⁸	2,345 ⁸	1,990 ⁷	2,550 ⁷	1,750 ⁹	4,020 ⁹	3,030 ⁷	1,550 ⁸	2,055 ⁷
Steel Strength in Shear, concrete on metal deck ⁴	$V_{sa,deck}$	lb.	2,285	3,085	3,430	4,680	3,235	5,430	6,135	3,085	5,955
Steel Strength in Shear, concrete on metal deck (seismic) ⁵	$V_{sa,deck,eq}$	lb.	2,285	3,085	2,400	3,275	3,235	5,430	5,520	3,085	4,170

- The information presented in this table must be used in conjunction with the design criteria of ACI 318 Appendix D, except as modified below.
- Profile steel deck must comply with the configuration in Figure 2 on the previous page, and have a minimum base-steel thickness of 0.035 inch [20 gauge]. Steel must comply with ASTM A 653/A 653M SS Grade 33 with minimum yield strength of 33,000 psi. Concrete compressive strength shall be 3,000 psi minimum.
- For anchors installed in the soffit of sand-lightweight or normal-weight concrete over metal deck floor and roof assemblies, calculation of the concrete breakout strength may be omitted.
- In accordance with ACI 318 Section D.5.3.2, the nominal pullout strength in cracked concrete for anchors installed in the soffit of sand-lightweight or normal-weight concrete over metal deck floor and roof assemblies $N_{p,deck,cr}$ shall be substituted for $N_{p,cr}$. Where analysis indicates no cracking at service loads, the normal pullout strength in uncracked concrete $N_{p,deck,uncr}$ shall be substituted for $N_{p,uncr}$. For seismic loads, $N_{p,deck,eq}$ shall be substituted for $N_{p,cr}$.
- In accordance with ACI 318 Section D.6.1.2(c), the shear strength for anchors installed in the soffit of sand-lightweight or normal-weight concrete over metal deck floor and roof assemblies $V_{sa,deck}$ shall be substituted for V_{sa} . For seismic loads, $V_{sa,deck,eq}$ shall be substituted for V_{sa} .
- The minimum anchor spacing along the flute must be the greater of $3.0h_{ef}$ or 1.5 times the flute width.
- The characteristic pull-out strength for greater concrete compressive strengths shall be increased by multiplying the tabular value by $(f'_c / 3,000 \text{ psi})^{0.5}$.
- The characteristic pull-out strength for greater concrete compressive strengths shall be increased by multiplying the tabular value by $(f'_c / 3,000 \text{ psi})^{0.3}$.
- The characteristic pull-out strength for greater concrete compressive strengths shall be increased by multiplying the tabular value by $(f'_c / 3,000 \text{ psi})^{0.4}$.
- Concrete shall be normal-weight or structural sand-lightweight concrete having a minimum specified compressive strength, f'_c , of 3,000 psi.
- Minimum distance to edge of panel is $2h_{ef}$.

* See page 12 for an explanation of the load table icons.

Strong-Bolt® 2 Design Information — Concrete

Carbon Steel Strong-Bolt® 2 Tension Design Strengths
in Normal-Weight Concrete ($f'_c = 2,500$ psi)



Anchor Dia. (in.)	Nominal Embed. Depth (in.)	Min. Concrete Thickness h_{min} (in.)	Critical Edge Distance c_{ac} (in.)	Minimum Edge Distance c_{min} (in.)	Tension Design Strength (lb.)							
					Edge Distances = c_{ac} on all sides				Edge Distances = c_{min} on one side and c_{ac} on three sides			
					SDC A-B ⁵		SDC C-F ^{6,7}		SDC A-B ⁵		SDC C-F ^{6,7}	
					Uncracked	Cracked	Uncracked	Cracked	Uncracked	Cracked	Uncracked	Cracked
1/4	1 3/4	3 1/4	2 1/2	1 3/4	1,435	—	—	—	1,070	—	—	—
3/8	1 7/8	3 1/4	6 1/2	6	1,435	845	1,075	635	1,325	845	990	635
	2 7/8	4 1/2	6	6	2,170	1,805	1,630	1,355	2,170	1,805	1,630	1,355
1/2	2 3/4	4 1/2	7	7	2,350	1,865	1,760	1,400	2,350	1,865	1,760	1,400
	3 7/8	6	7 1/2	4	3,415	2,430	2,560	1,820	2,740	2,430	2,055	1,820
5/8	3 3/8	5 1/2	7 1/2	6 1/2	3,555	2,520	2,665	1,890	3,085	2,520	2,310	1,890
	5 1/8	7 7/8	9	6 1/2	5,865	4,480	4,400	3,360	5,420	4,480	4,065	3,360
3/4	4 1/8	6 3/4	9	6 1/2	4,625	3,425	3,470	2,570	3,495	3,425	2,620	2,570
	5 3/4	8 3/4	8	6 1/2	5,765	5,525	4,325	4,145	5,765	5,525	4,325	4,145
1	5 1/4	9	18	8	4,600	4,235	3,450	3,175	2,800	4,235	2,100	3,175
	9 3/4	13 1/2	13 1/2	8	5,330	6,150	3,995	4,615	5,330	6,150	3,995	4,615

- Tension design strengths are based on the strength design provisions of ACI 318-11 Appendix D.
- Tabulated values are for a single anchor with no influence of another anchor.
- Interpolation between embedment depths is not permitted.
- Strength reduction factor, ϕ , is based on using a load combination from ACI 318-11 Section 9.2.
- The tension design strength listed for SDC (Seismic Design Category) A-B may also be used in SDC C-F when the tension component of the strength-level seismic design load on the anchor does not exceed 20% of the total factored tension load on the anchor associated with the same load combination.
- When designing anchorages in SDC C-F, the designer shall consider the ductility requirements of ACI 318-11 Section D.3.3.
- Tension design strengths in SDC C-F have been adjusted by 0.75 factor in accordance with ACI 318-11 Section D.3.3.4.4.

Carbon Steel Strong-Bolt® 2 Allowable Tension Loads
in Normal-Weight Concrete ($f'_c = 2,500$ psi) — Static Load



Anchor Dia. (in.)	Nominal Embed. Depth (in.)	Min. Concrete Thickness h_{min} (in.)	Critical Edge Distance c_{ac} (in.)	Minimum Edge Distance c_{min} (in.)	Allowable Tension Load (lb.)			
					Edge Distances = c_{ac} on all sides		Edge Distances = c_{min} on one side and c_{ac} on three sides	
					Uncracked	Cracked	Uncracked	Cracked
1/4	1 3/4	3 1/4	2 1/2	1 3/4	1,025	—	765	—
3/8	1 7/8	3 1/4	6 1/2	6	1,025	605	945	605
	2 7/8	4 1/2	6	6	1,550	1,290	1,550	1,290
1/2	2 3/4	4 1/2	7	7	1,680	1,330	1,680	1,330
	3 7/8	6	7 1/2	4	2,440	1,735	1,955	1,735
5/8	3 3/8	5 1/2	7 1/2	6 1/2	2,540	1,800	2,205	1,800
	5 1/8	7 7/8	9	6 1/2	4,190	3,200	3,870	3,200
3/4	4 1/8	6 3/4	9	6 1/2	3,305	2,445	2,495	2,445
	5 3/4	8 3/4	8	6 1/2	4,120	3,945	4,120	3,945
1	5 1/4	9	18	8	3,285	3,025	2,000	3,025
	9 3/4	13 1/2	13 1/2	8	3,805	4,395	3,805	4,395

- Allowable tension loads are calculated based on the strength design provision of ACI 318-11 Appendix D using a conversion factor of $\alpha = 1.4$. The conversion factor α is based on the load combination 1.2D + 1.6L assuming 50% dead load and 50% live load: $1.2(0.5) + 1.6(0.5) = 1.4$.
- Tabulated values are for a single anchor with no influence of another anchor.
- Interpolation between embedment depths is not permitted.

* See page 12 for an explanation of the load table icons.

Strong-Bolt® 2 Design Information — Concrete

Carbon Steel Strong-Bolt® 2 Allowable Tension Loads in Normal-Weight Concrete ($f'_c = 2,500$ psi) — Wind Load



Anchor Dia. (in.)	Nominal Embed. Depth (in.)	Min. Concrete Thickness h_{min} (in.)	Critical Edge Distance c_{ac} (in.)	Minimum Edge Distance c_{min} (in.)	Allowable Tension Load (lb.)			
					Edge Distances = c_{ac} on all sides		Edge Distances = c_{min} on one side and c_{ac} on three sides	
					Uncracked	Cracked	Uncracked	Cracked
1/4	1 3/4	3 1/4	2 1/2	1 3/4	860	—	640	—
3/8	1 7/8	3 1/4	6 1/2	6	860	505	795	505
	2 7/8	4 1/2	6	6	1,300	1,085	1,300	1,085
1/2	2 3/4	4 1/2	7	7	1,410	1,120	1,410	1,120
	3 7/8	6	7 1/2	4	2,050	1,460	1,645	1,460
5/8	3 3/8	5 1/2	7 1/2	6 1/2	2,135	1,510	1,850	1,510
	5 1/8	7 7/8	9	6 1/2	3,520	2,690	3,250	2,690
3/4	4 1/8	6 3/4	9	6 1/2	2,775	2,055	2,095	2,055
	5 3/4	8 3/4	8	6 1/2	3,460	3,315	3,460	3,315
1	5 1/4	9	18	8	2,760	2,540	1,680	2,540
	9 3/4	13 1/2	13 1/2	8	3,200	3,690	3,200	3,690

1. Allowable tension loads are calculated based on the strength design provision of ACI 318-11 Appendix D using a conversion factor of $\alpha = 1/6.6 = 1.67$. The conversion factor α is based on the load combination assuming 100% wind load.
2. Tabulated values are for a single anchor with no influence of another anchor.
3. Interpolation between embedment depths is not permitted.

Carbon Steel Strong-Bolt® 2 Allowable Tension Loads in Normal-Weight Concrete ($f'_c = 2,500$ psi) — Seismic Load



Anchor Dia. (in.)	Nominal Embed. Depth (in.)	Min. Concrete Thickness h_{min} (in.)	Critical Edge Distance c_{ac} (in.)	Minimum Edge Distance c_{min} (in.)	Allowable Tension Load (lb.)							
					Edge Distances = c_{ac} on all sides				Edge Distances = c_{min} on one side and c_{ac} on three sides			
					SDC A-B ⁴		SDC C-F ^{5,6}		SDC A-B ⁴		SDC C-F ^{5,6}	
					Uncracked	Cracked	Uncracked	Cracked	Uncracked	Cracked	Uncracked	Cracked
1/4	1 3/4	3 1/4	2 1/2	1 3/4	1,005	—	—	—	750	—	—	—
3/8	1 7/8	3 1/4	6 1/2	6	1,005	590	755	445	930	590	695	445
	2 7/8	4 1/2	6	6	1,520	1,265	1,140	950	1,520	1,265	1,140	950
1/2	2 3/4	4 1/2	7	7	1,645	1,305	1,230	980	1,645	1,305	1,230	980
	3 7/8	6	7 1/2	4	2,390	1,700	1,790	1,275	1,920	1,700	1,440	1,275
5/8	3 3/8	5 1/2	7 1/2	6 1/2	2,490	1,765	1,865	1,325	2,160	1,765	1,615	1,325
	5 1/8	7 7/8	9	6 1/2	4,105	3,135	3,080	2,350	3,795	3,135	2,845	2,350
3/4	4 1/8	6 3/4	9	6 1/2	3,240	2,400	2,430	1,800	2,445	2,400	1,835	1,800
	5 3/4	8 3/4	8	6 1/2	4,035	3,870	3,030	2,900	4,035	3,870	3,030	2,900
1	5 1/4	9	18	8	3,220	2,965	2,415	2,225	1,960	2,965	1,470	2,225
	9 3/4	13 1/2	13 1/2	8	3,730	4,305	2,795	3,230	3,730	4,305	2,795	3,230

1. Allowable tension loads are calculated based on the strength design provision of ACI 318-11 Appendix D using a conversion factor of $\alpha = 1/6.7 = 1.43$. The conversion factor α is based on the load combination assuming 100% seismic load.
2. Tabulated values are for a single anchor with no influence of another anchor.
3. Interpolation between embedment depths is not permitted.
4. The allowable tension load listed for SDC (Seismic Design Category) A-B may also be used in SDC C-F when the tension component of the strength-level seismic design load on the anchor does not exceed 20% of the total factored tension load on the anchor associated with the same load combination.
5. When designing anchorages in SDC C-F, the designer shall consider the ductility requirements of ACI 318-11 Section D.3.3.
6. Tension design strengths in SDC C-F have been adjusted by 0.75 factor in accordance with ACI 318-11 Section D.3.3.4.4.

* See page 12 for an explanation of the load table icons.

Strong-Bolt® 2 Design Information — Concrete



Stainless Steel Strong-Bolt® 2 Tension Design Strengths in Normal-Weight Concrete ($f'_c = 2,500$ psi)

Anchor Dia. (in.)	Nominal Embed. Depth (in.)	Min. Concrete Thickness h_{min} (in.)	Critical Edge Distance c_{ac} (in.)	Minimum Edge Distance c_{min} (in.)	Tension Design Strength (lb.)							
					Edge Distances = c_{ac} on all sides				Edge Distances = c_{min} on one side and c_{ac} on three sides			
					SDC A-B ⁵		SDC C-F ^{6,7}		SDC A-B ⁵		SDC C-F ^{6,7}	
					Uncracked	Cracked	Uncracked	Cracked	Uncracked	Cracked	Uncracked	Cracked
1/4	1 3/4	3 1/4	2 1/2	1 3/4	1,250	—	—	—	1,070	—	—	—
3/8	1 7/8	3 1/4	6 1/2	6	1,435	1,015	1,075	760	1,325	1,015	990	760
	2 7/8	4 1/2	8 1/2	6	3,085	2,045	2,090	1,380	2,175	2,045	1,630	1,380
1/2	2 3/4	4 1/2	6 1/2	6 1/2	2,100	1,665	1,575	1,250	2,100	1,665	1,575	1,250
	3 7/8	6	7	5	2,920	2,800	2,190	2,100	2,920	2,800	2,190	2,100
5/8	3 3/8	5 1/2	7 1/2	4	3,555	2,520	2,665	1,890	1,910	2,460	1,430	1,845
	5 1/8	7 7/8	9	4	4,950	4,255	3,710	3,190	3,905	3,685	2,925	2,765
3/4	4 1/8	6 3/4	8	6	4,835	3,425	3,625	2,570	3,625	3,425	2,720	2,570
	5 3/4	8 3/4	8	6	6,255	5,350	4,690	4,010	6,255	5,225	4,690	3,920

1. Tension design strengths are based on the strength design provisions of ACI 318-11 Appendix D.
2. Tabulated values are for a single anchor with no influence of another anchor.
3. Interpolation between embedment depths is not permitted.
4. Strength reduction factor, ϕ , is based on using a load combination from ACI 318-11 Section 9.2.
5. The tension design strength listed for SDC (Seismic Design Category) A-B may also be used in SDC C-F when the tension component of the strength-level seismic design load on the anchor does not exceed 20% of the total factored tension load on the anchor associated with the same load combination.
6. When designing anchorages in SDC C-F, the designer shall consider the ductility requirements of ACI 318-11 Section D.3.3.
7. Tension design strengths in SDC C-F have been adjusted by 0.75 factor in accordance with ACI 318-11 Section D.3.3.4.4.

Mechanical Anchors

Stainless Steel Strong-Bolt® 2 Allowable Tension Loads in Normal-Weight Concrete ($f'_c = 2,500$ psi) — Static Load



Anchor Dia. (in.)	Nominal Embed. Depth (in.)	Min. Concrete Thickness h_{min} (in.)	Critical Edge Distance c_{ac} (in.)	Minimum Edge Distance c_{min} (in.)	Allowable Tension Load (lb.)			
					Edge Distances = c_{ac} on all sides		Edge Distances = c_{min} on one side and c_{ac} on three sides	
					Uncracked	Cracked	Uncracked	Cracked
1/4	1 3/4	3 1/4	2 1/2	1 3/4	895	—	765	—
3/8	1 7/8	3 1/4	6 1/2	6	1,025	725	945	725
	2 7/8	4 1/2	8 1/2	6	2,205	1,460	1,555	1,460
1/2	2 3/4	4 1/2	6 1/2	6 1/2	1,500	1,190	1,500	1,190
	3 7/8	6	7	5	2,085	2,000	2,085	2,000
5/8	3 3/8	5 1/2	7 1/2	4	2,540	1,800	1,365	1,755
	5 1/8	7 7/8	9	4	3,535	3,040	2,790	2,630
3/4	4 1/8	6 3/4	8	6	3,455	2,445	2,590	2,445
	5 3/4	8 3/4	8	6	4,470	3,820	4,470	3,730

1. Allowable tension loads are calculated based on the strength design provision of ACI 318-11 Appendix D using a conversion factor of $\alpha = 1.4$. The conversion factor α is based on the load combination $1.2D + 1.6L$ assuming 50% dead load and 50% live load: $1.2(0.5) + 1.6(0.5) = 1.4$.
2. Tabulated values are for a single anchor with no influence of another anchor.
3. Interpolation between embedment depths is not permitted.

* See page 12 for an explanation of the load table icons.

Strong-Bolt® 2 Design Information — Concrete

Stainless Steel Strong-Bolt® 2 Allowable Tension Loads in Normal-Weight Concrete ($f'_c = 2,500$ psi) — Wind Load



Anchor Dia. (in.)	Nominal Embed. Depth (in.)	Min. Concrete Thickness h_{min} (in.)	Critical Edge Distance c_{ac} (in.)	Minimum Edge Distance c_{min} (in.)	Allowable Tension Load (lb.)			
					Edge Distances = c_{ac} on all sides		Edge Distances = c_{min} on one side and c_{ac} on three sides	
					Uncracked	Cracked	Uncracked	Cracked
1/4	1 3/4	3 1/4	2 1/2	1 3/4	750	—	640	—
3/8	1 7/8	3 1/4	6 1/2	6	860	610	795	610
	2 7/8	4 1/2	8 1/2	6	1,850	1,225	1,305	1,225
1/2	2 3/4	4 1/2	6 1/2	6 1/2	1,260	1,000	1,260	1,000
	3 7/8	6	7	5	1,750	1,680	1,750	1,680
5/8	3 3/8	5 1/2	7 1/2	4	2,135	1,510	1,145	1,475
	5 1/8	7 7/8	9	4	2,970	2,555	2,345	2,210
3/4	4 1/8	6 3/4	8	6	2,900	2,055	2,175	2,055
	5 3/4	8 3/4	8	6	3,755	3,210	3,755	3,135

1. Allowable tension loads are calculated based on the strength design provision of ACI 318-11 Appendix D using a conversion factor of $\alpha = 1/0.6 = 1.67$. The conversion factor α is based on the load combination assuming 100% wind load.
2. Tabulated values are for a single anchor with no influence of another anchor.
3. Interpolation between embedment depths is not permitted.

Stainless Steel Strong-Bolt® 2 Allowable Tension Loads in Normal-Weight Concrete ($f'_c = 2,500$ psi) — Seismic Load



Anchor Dia. (in.)	Nominal Embed. Depth (in.)	Min. Concrete Thickness h_{min} (in.)	Critical Edge Distance c_{ac} (in.)	Minimum Edge Distance c_{min} (in.)	Allowable Tension Load (lb.)							
					Edge Distances = c_{ac} on all sides				Edge Distances = c_{min} on one side and c_{ac} on three sides			
					SDC A-B ⁴		SDC C-F ^{5,6}		SDC A-B ⁴		SDC C-F ^{5,6}	
					Uncracked	Cracked	Uncracked	Cracked	Uncracked	Cracked	Uncracked	Cracked
1/4	1 3/4	3 1/4	2 1/2	1 3/4	875	—	—	—	750	—	—	—
3/8	1 7/8	3 1/4	6 1/2	6	1,005	710	755	530	930	710	695	530
	2 7/8	4 1/2	8 1/2	6	2,160	1,430	1,465	965	1,525	1,430	1,140	965
1/2	2 3/4	4 1/2	6 1/2	6 1/2	1,470	1,165	1,105	875	1,470	1,165	1,105	875
	3 7/8	6	7	5	2,045	1,960	1,535	1,470	2,045	1,960	1,535	1,470
5/8	3 3/8	5 1/2	7 1/2	4	2,490	1,765	1,865	1,325	1,335	1,720	1,000	1,290
	5 1/8	7 7/8	9	4	3,465	2,980	2,595	2,235	2,735	2,580	2,050	1,935
3/4	4 1/8	6 3/4	8	6	3,385	2,400	2,540	1,800	2,540	2,400	1,905	1,800
	5 3/4	8 3/4	8	6	4,380	3,745	3,285	2,805	4,380	3,660	3,285	2,745

1. Allowable tension loads are calculated based on the strength design provision of ACI 318-11 Appendix D using a conversion factor of $\alpha = 1/0.7 = 1.43$. The conversion factor α is based on the load combination assuming 100% seismic load.
2. Tabulated values are for a single anchor with no influence of another anchor.
3. Interpolation between embedment depths is not permitted.
4. The allowable tension load listed for SDC (Seismic Design Category) A-B may also be used in SDC C-F when the tension component of the strength-level seismic design load on the anchor does not exceed 20% of the total factored tension load on the anchor associated with the same load combination.
5. When designing anchorages in SDC C-F, the designer shall consider the ductility requirements of ACI 318-11 Section D.3.3.
6. Tension design strengths in SDC C-F have been adjusted by 0.75 factor in accordance with ACI 318-11 Section D.3.3.4.4.

C-A-2016 © 2015 SIMPSON STRONG-TIE COMPANY, INC.

Mechanical Anchors

* See page 12 for an explanation of the load table icons.

Strong-Bolt® 2 Design Information — Concrete

Carbon Steel Strong-Bolt® 2 Tension Design Strengths in Soffit of Normal-Weight or Sand-Lightweight Concrete-Filled Profile Steel Deck Assemblies ($f'_c = 3,000$ psi)



Anchor Dia. (in.)	Nominal Embed. Depth (in.)	Minimum End Distance c_{min} (in.)	Tension Design Strength (lb.)							
			Lower Flute				Upper Flute			
			SDC A-B ⁵		SDC C-F ^{6,7}		SDC A-B ⁵		SDC C-F ^{6,7}	
Uncracked	Cracked	Uncracked	Cracked	Uncracked	Cracked	Uncracked	Cracked			
3/8	2	3 1/4	1,145	675	860	505	1,480	870	1,110	655
	3 3/8	6	2,050	1,700	1,535	1,275	—	—	—	—
1/2	2 3/4	4 1/2	1,675	1,325	1,260	995	3,115	2,460	2,340	1,845
	4 1/2	8	2,495	1,775	1,870	1,330	—	—	—	—
5/8	3 3/8	5 1/2	2,395	1,700	1,795	1,275	—	—	—	—
	5 5/8	10	4,265	3,245	3,200	2,435	—	—	—	—
3/4	4 1/8	6 3/4	2,470	1,830	1,855	1,370	—	—	—	—

1. Tension design strengths are based on the strength design provisions of ACI 318-11 Appendix D.
2. Tabulated values are for a single anchor with no influence of another anchor.
3. Interpolation between embedment depths is not permitted.
4. Strength reduction factor, ϕ , is based on using a load combination from ACI 318-11 Section 9.2.
5. The tension design strength listed for SDC (Seismic Design Category) A-B may also be used in SDC C-F when the tension component of the strength-level seismic design load on the anchor does not exceed 20% of the total factored tension load on the anchor associated with the same load combination.
6. When designing anchorages in SDC C-F, the designer shall consider the ductility requirements of ACI 318-11 Section D.3.3.
7. Tension design strengths in SDC C-F have been adjusted by 0.75 factor in accordance with ACI 318-11 Section D.3.3.4.4.
8. Installation must comply with Figure 2 on page 152.

Carbon Steel Strong-Bolt® 2 Allowable Tension Loads in Soffit of Normal-Weight or Sand-Lightweight Concrete-Filled Profile Steel Deck Assemblies ($f'_c = 3,000$ psi) — Static Load



Anchor Dia. (in.)	Nominal Embed. Depth (in.)	Minimum End Distance c_{min} (in.)	Allowable Tension Load (lb.)			
			Lower Flute		Upper Flute	
			Uncracked	Cracked	Uncracked	Cracked
3/8	2	3 1/4	820	480	1,055	620
	3 3/8	6	1,465	1,215	—	—
1/2	2 3/4	4 1/2	1,195	945	2,225	1,755
	4 1/2	8	1,780	1,270	—	—
5/8	3 3/8	5 1/2	1,710	1,215	—	—
	5 5/8	10	3,045	2,320	—	—
3/4	4 1/8	6 3/4	1,765	1,305	—	—

1. Allowable tension loads are calculated based on the strength design provision of ACI 318-11 Appendix D using a conversion factor of $\alpha = 1.4$. The conversion factor α is based on the load combination $1.2D + 1.6L$ assuming 50% dead load and 50% live load: $1.2(0.5) + 1.6(0.5) = 1.4$.
2. Tabulated values are for a single anchor with no influence of another anchor.
3. Interpolation between embedment depths is not permitted.
4. Installation must comply with Figure 2 on page 152.

* See page 12 for an explanation of the load table icons.

Strong-Bolt® 2 Design Information — Concrete

Carbon Steel Strong-Bolt® 2 Allowable Tension Loads in Soffit of Normal-Weight or Sand-Lightweight Concrete-Filled Profile Steel Deck Assemblies ($f'_c = 3,000$ psi) — Wind Load



Anchor Dia. (in.)	Nominal Embed. Depth (in.)	Minimum End Distance c_{min} (in.)	Allowable Tension Load (lb.)			
			Lower Flute		Upper Flute	
			Uncracked	Cracked	Uncracked	Cracked
3/8	2	3 1/4	685	405	890	520
	3 3/8	6	1,230	1,020	—	—
1/2	2 3/4	4 1/2	1,005	795	1,870	1,475
	4 1/2	8	1,495	1,065	—	—
5/8	3 3/8	5 1/2	1,435	1,020	—	—
	5 5/8	10	2,560	1,945	—	—
3/4	4 1/8	6 3/4	1,480	1,100	—	—

1. Allowable tension loads are calculated based on the strength design provision of ACI 318-11 Appendix D using a conversion factor of $\alpha = 1/1.67 = 0.6$. The conversion factor α is based on the load combination assuming 100% wind load.
2. Tabulated values are for a single anchor with no influence of another anchor.
3. Interpolation between embedment depths is not permitted.
4. Installation must comply with Figure 2 on page 152.

Carbon Steel Strong-Bolt® 2 Allowable Tension Loads in Soffit of Normal-Weight or Sand-Lightweight Concrete-Filled Profile Steel Deck Assemblies ($f'_c = 3,000$ psi) — Seismic Load



Anchor Dia. (in.)	Nominal Embed. Depth (in.)	Minimum End Distance c_{min} (in.)	Allowable Tension Load (lb.)							
			Lower Flute				Upper Flute			
			SDC A-B ⁴		SDC C-F ^{5,6}		SDC A-B ⁴		SDC C-F ^{5,6}	
Uncracked	Cracked	Uncracked	Cracked	Uncracked	Cracked	Uncracked	Cracked	Uncracked	Cracked	
3/8	2	3 1/4	800	475	600	355	1,035	610	775	460
	3 3/8	6	1,435	1,190	1,075	895	—	—	—	—
1/2	2 3/4	4 1/2	1,175	930	880	695	2,180	1,720	1,640	1,290
	4 1/2	8	1,745	1,245	1,310	930	—	—	—	—
5/8	3 3/8	5 1/2	1,675	1,190	1,255	895	—	—	—	—
	5 5/8	10	2,985	2,270	2,240	1,705	—	—	—	—
3/4	4 1/8	6 3/4	1,730	1,280	1,300	960	—	—	—	—

1. Allowable tension loads are calculated based on the strength design provision of ACI 318-11 Appendix D using a conversion factor of $\alpha = 1/1.43 = 0.7$. The conversion factor α is based on the load combination assuming 100% seismic load.
2. Tabulated values are for a single anchor with no influence of another anchor.
3. Interpolation between embedment depths is not permitted.
4. The allowable tension load listed for SDC (Seismic Design Category) A-B may also be used in SDC C-F when the tension component of the strength-level seismic design load on the anchor does not exceed 20% of the total factored tension load on the anchor associated with the same load combination.
5. When designing anchorages in SDC C-F, the designer shall consider the ductility requirements of ACI 318-11 Section D.3.3.
6. Tension design strengths in SDC C-F have been adjusted by 0.75 factor in accordance with ACI 318-11 Section D.3.3.4.4.
7. Installation must comply with Figure 2 on page 152.

* See page 12 for an explanation of the load table icons.

Strong-Bolt® 2 Design Information — Concrete

Stainless Steel Strong-Bolt® 2 Tension Design Strengths in Soffit of Normal-Weight or Sand-Lightweight Concrete-Filled Profile Steel Deck Assemblies ($f'_c = 3,000$ psi)

Anchor Dia. (in.)	Nominal Embed. Depth (in.)	Minimum End Distance c_{min} (in.)	Tension Design Strength (lb.)							
			Lower Flute				Upper Flute			
			SDC A-B ⁵		SDC C-F ^{6,7}		SDC A-B ⁵		SDC C-F ^{6,7}	
			Uncracked	Cracked	Uncracked	Cracked	Uncracked	Cracked	Uncracked	Cracked
3/8	2	3 1/4	1,025	800	770	600	1,295	1,010	970	755
	3 3/8	6	2,570	1,695	1,735	1,145	—	—	—	—
1/2	2 3/4	4 1/2	1,610	1,295	1,205	970	1,665	1,335	1,250	1,000
	4 1/2	8	1,730	1,660	1,295	1,245	—	—	—	—
5/8	3 3/8	5 1/2	1,605	1,135	1,205	855	—	—	—	—
	5 5/8	10	3,250	2,615	2,440	1,960	—	—	—	—
3/4	4 1/8	6 3/4	2,780	1,970	2,085	1,475	—	—	—	—

1. Tension design strengths are based on the strength design provisions of ACI 318-11 Appendix D.
2. Tabulated values are for a single anchor with no influence of another anchor.
3. Interpolation between embedment depths is not permitted.
4. Strength reduction factor, ϕ , is based on using a load combination from ACI 318-11 Section 9.2.
5. The tension design strength listed for SDC (Seismic Design Category) A-B may also be used in SDC C-F when the tension component of the strength-level seismic design load on the anchor does not exceed 20% of the total factored tension load on the anchor associated with the same load combination.
6. When designing anchorages in SDC C-F, the designer shall consider the ductility requirements of ACI 318-11 Section D.3.3.
7. Tension design strengths in SDC C-F have been adjusted by 0.75 factor in accordance with ACI 318-11 Section D.3.3.4.4.
8. Installation must comply with Figure 2 on page 152.

Stainless Steel Strong-Bolt® 2 Allowable Tension Loads in Soffit of Normal-Weight or Sand-Lightweight Concrete-Filled Profile Steel Deck Assemblies ($f'_c = 3,000$ psi) — Static Load

Anchor Dia. (in.)	Nominal Embed. Depth (in.)	Minimum End Distance c_{min} (in.)	Allowable Tension Load (lb.)			
			Lower Flute		Upper Flute	
			Uncracked	Cracked	Uncracked	Cracked
3/8	2	3 1/4	730	570	925	720
	3 3/8	6	1,835	1,210	—	—
1/2	2 3/4	4 1/2	1,150	925	1,190	955
	4 1/2	8	1,235	1,185	—	—
5/8	3 3/8	5 1/2	1,145	810	—	—
	5 5/8	10	2,320	1,870	—	—
3/4	4 1/8	6 3/4	1,985	1,405	—	—

1. Allowable tension loads are calculated based on the strength design provision of ACI 318-11 Appendix D using a conversion factor of $\alpha = 1.4$. The conversion factor α is based on the load combination 1.2D + 1.6L assuming 50% dead load and 50% live load: $1.2(0.5) + 1.6(0.5) = 1.4$.
2. Tabulated values are for a single anchor with no influence of another anchor.
3. Interpolation between embedment depths is not permitted.
4. Installation must comply with Figure 2 on page 152.

* See page 12 for an explanation of the load table icons.

Strong-Bolt® 2 Design Information — Concrete

Stainless Steel Strong-Bolt® 2 Allowable Tension Loads in Soffit of Normal-Weight or Sand-Lightweight Concrete-Filled Profile Steel Deck Assemblies ($f'_c = 3,000$ psi) — Wind Load

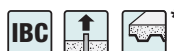

Anchor Dia. (in.)	Nominal Embed. Depth (in.)	Minimum End Distance c_{min} (in.)	Allowable Tension Load (lb.)			
			Lower Flute		Upper Flute	
			Uncracked	Cracked	Uncracked	Cracked
3/8	2	3 1/4	615	480	775	605
	3 3/8	6	1,540	1,015	—	—
1/2	2 3/4	4 1/2	965	775	1,000	800
	4 1/2	8	1,040	995	—	—
5/8	3 3/8	5 1/2	965	680	—	—
	5 5/8	10	1,950	1,570	—	—
3/4	4 1/8	6 3/4	1,670	1,180	—	—

1. Allowable tension loads are calculated based on the strength design provision of ACI 318-11 Appendix D using a conversion factor of $\alpha = 1/0.6 = 1.67$. The conversion factor α is based on the load combination assuming 100% wind load.
2. Tabulated values are for a single anchor with no influence of another anchor.
3. Interpolation between embedment depths is not permitted.
4. Installation must comply with Figure 2 on page 152.

Stainless Steel Strong-Bolt® 2 Allowable Tension Loads in Soffit of Normal-Weight or Sand-Lightweight Concrete-Filled Profile Steel Deck Assemblies ($f'_c = 3,000$ psi) — Seismic Load



Anchor Dia. (in.)	Nominal Embed. Depth (in.)	Minimum End Distance c_{min} (in.)	Allowable Tension Load (lb.)							
			Lower Flute				Upper Flute			
			SDC A-B ⁴		SDC C-F ^{5,6}		SDC A-B ⁴		SDC C-F ^{5,6}	
Uncracked	Cracked	Uncracked	Cracked	Uncracked	Cracked	Uncracked	Cracked	Uncracked	Cracked	
3/8	2	3 1/4	720	560	540	420	905	705	680	530
	3 3/8	6	1,800	1,185	1,215	800	—	—	—	—
1/2	2 3/4	4 1/2	1,125	905	845	680	1,165	935	875	700
	4 1/2	8	1,210	1,160	905	870	—	—	—	—
5/8	3 3/8	5 1/2	1,125	795	845	600	—	—	—	—
	5 5/8	10	2,275	1,830	1,710	1,370	—	—	—	—
3/4	4 1/8	6 3/4	1,945	1,380	1,460	1,035	—	—	—	—

1. Allowable tension loads are calculated based on the strength design provision of ACI 318-11 Appendix D using a conversion factor of $\alpha = 1/0.7 = 1.43$. The conversion factor α is based on the load combination assuming 100% seismic load.
2. Tabulated values are for a single anchor with no influence of another anchor.
3. Interpolation between embedment depths is not permitted.
4. The allowable tension load listed for SDC (Seismic Design Category) A-B may also be used in SDC C-F when the tension component of the strength-level seismic design load on the anchor does not exceed 20% of the total factored tension load on the anchor associated with the same load combination.
5. When designing anchorages in SDC C-F, the designer shall consider the ductility requirements of ACI 318-11 Section D.3.3.
6. Tension design strengths in SDC C-F have been adjusted by 0.75 factor in accordance with ACI 318-11 Section D.3.3.4.4.
7. Installation must comply with Figure 2 on page 152.

* See page 12 for an explanation of the load table icons.

Strong-Bolt® 2 Design Information — Masonry

Carbon-Steel Strong-Bolt® 2 Tension and Shear Loads in 8" Lightweight, Medium-Weight and Normal-Weight Grout-Filled CMU

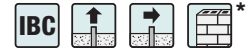

Mechanical Anchors

Size in. (mm)	Drill Bit Dia. (in.)	Min. Embed. Depth in. (mm)	Install. Torque ft.-lb. (N-m)	Critical Edge Dist. in. (mm)	Critical End Dist. in. (mm)	Critical Spacing in. (mm)	Tension Load		Shear Load	
							Ultimate lb. (kN)	Allowable lb. (kN)	Ultimate lb. (kN)	Allowable lb. (kN)
Anchor Installed in the Face of the CMU Wall (See Figure 1)										
1/4 (6.4)	1/4	1 3/4 (45)	4 (5.4)	12 (305)	12 (305)	8 (203)	1,150 (5.1)	230 (1.0)	1,500 (6.7)	300 (1.3)
3/8 (9.5)	3/8	2 5/8 (67)	20 (27.1)	12 (305)	12 (305)	8 (203)	2,185 (9.7)	435 (1.9)	3,875 (17.2)	775 (3.4)
1/2 (12.7)	1/2	3 1/2 (89)	35 (47.5)	12 (305)	12 (305)	8 (203)	2,645 (11.8)	530 (2.4)	5,055 (22.5)	1,010 (4.5)
5/8 (15.9)	5/8	4 3/8 (111)	55 (74.6)	20 (508)	20 (508)	8 (203)	4,460 (19.8)	890 (4.0)	8,815 (39.2)	1,765 (7.9)
3/4 (19.1)	3/4	5 1/4 (133)	100 (135.6)	20 (508)	20 (508)	8 (203)	5,240 (23.3)	1,050 (4.7)	12,450 (55.4)	2,490 (11.1)

- The tabulated allowable loads are based on a safety factor of 5.0 for installation under the IBC and IRC.
- Listed loads may be applied to installations on the face of the CMU wall at least 1 1/4 inch away from headjoints.
- Values for 8-inch-wide concrete masonry units (CMU) with a minimum specified compressive strength of masonry, f'_m , at 28 days is 1,500 psi.
- Embedment depth is measured from the outside face of the concrete masonry unit.
- Tension and shear loads may be combined using the parabolic interaction equation ($n = 5/8$).
- Refer to allowable load adjustment factors for edge distance and spacing on page 163.
- Allowable loads may be increased 33 1/3% for short-term loading due to wind forces or seismic forces where permitted by code.

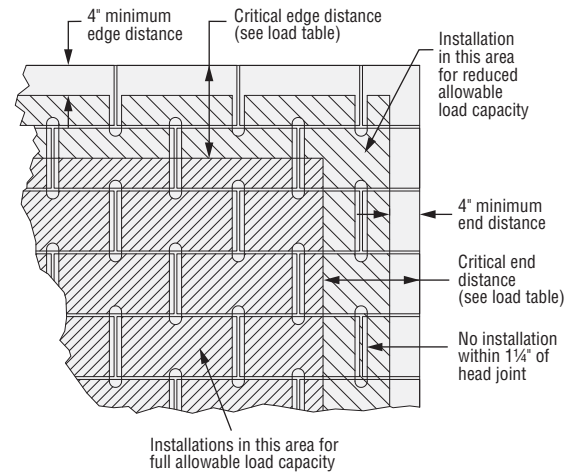

Figure 1

Carbon-Steel Strong-Bolt® 2 Tension and Shear Loads in 8" Lightweight, Medium-weight and Normal-Weight Grout-Filled CMU



Size in. (mm)	Drill Bit Dia. in.	Min. Embed. Depth in. (mm)	Install. Torque ft.-lb. (N-m)	Min. Edge Dist. in. (mm)	Critical End Dist. in. (mm)	Critical Spacing in. (mm)	Tension Load		Shear Load Perp. To Edge		Shear Load Parallel To Edge	
							Ultimate lb. (kN)	Allowable lb. (kN)	Ultimate lb. (kN)	Allowable lb. (kN)	Ultimate lb. (kN)	Allowable lb. (kN)
Anchor Installed in Cell Opening or Web (Top of Wall) (See Figure 2)												
1/2 (12.7)	1/2	3 1/2 (89)	35 (47.5)	1 3/4 (45)	12 (305)	8 (203)	2,080 (9.3)	415 (1.8)	1,165 (5.2)	235 (1.0)	3,360 (14.9)	670 (3.0)
5/8 (15.9)	5/8	4 3/8 (111)	55 (74.6)	1 3/4 (45)	12 (305)	8 (203)	3,200 (14.2)	640 (2.8)	1,370 (6.1)	275 (1.2)	3,845 (17.1)	770 (3.4)

- The tabulated allowable loads are based on a safety factor of 5.0 for installation under the IBC and IRC.
- Values for 8-inch-wide concrete masonry units (CMU) with a minimum specified compressive strength of masonry, f'_m , at 28 days is 1,500 psi.
- Tension and shear loads may be combined using the parabolic interaction equation ($n = 5/8$).
- Refer to allowable load adjustment factors for edge distance and spacing on page 163.
- Allowable loads may be increased 33 1/3% for short-term loading due to wind forces or seismic forces where permitted by code.

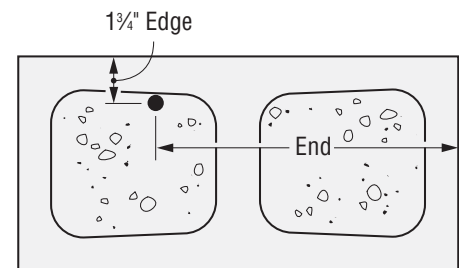

Figure 2

* See page 12 for an explanation of the load table icons.

Strong-Bolt® 2 Design Information — Masonry

Carbon-Steel Strong-Bolt® 2 Allowable Load Adjustment Factors for Face-of-Wall Installation in 8" Grout-Filled CMU: Edge Distance and Spacing, Tension and Shear Loads

How to use these charts:

1. The following tables are for reduced edge distance and spacing.
2. Locate the anchor size to be used for either a tension and/or shear load application.
3. Locate the embedment (E) at which the anchor is to be installed.
4. Locate the edge distance (c_{act}) or spacing (s_{act}) at which the anchor is to be installed.
5. The load adjustment factor (f_c or f_s) is the intersection of the row and column.
6. Multiply the allowable load by the applicable load adjustment factor.
7. Reduction factors for multiple edges or spacings are multiplied together.

Edge or End Distance Tension (f_c)

c_{act} (in.)	Dia.	¼	⅜	½	⅝	¾	IBC*
	E	1¼	2⅝	3½	4⅞	5¼	
	c_{cr}	12	12	12	20	20	
	c_{min}	2	4	4	4	4	
	f_{cmin}	1.00	1.00	1.00	1.00	0.97	
2		1.00					
4		1.00	1.00	1.00	1.00	0.97	
6		1.00	1.00	1.00	1.00	0.97	
8		1.00	1.00	1.00	1.00	0.98	
10		1.00	1.00	1.00	1.00	0.98	
12		1.00	1.00	1.00	1.00	0.99	
14					1.00	0.99	
16					1.00	0.99	
18					1.00	1.00	
20					1.00	1.00	

Edge or End Distance Shear (f_c)

c_{act} (in.)	Dia.	¼	⅜	½	⅝	¾	IBC*
	E	1¼	2⅝	3½	4⅞	5¼	
	c_{cr}	12	12	12	20	20	
	c_{min}	2	4	4	4	4	
	f_{cmin}	0.88	0.71	0.60	0.36	0.28	
2		0.88					
4		0.90	0.71	0.60	0.36	0.28	
6		0.93	0.78	0.70	0.44	0.37	
8		0.95	0.86	0.80	0.52	0.46	
10		0.98	0.93	0.90	0.60	0.55	
12		1.00	1.00	1.00	0.68	0.64	
14					0.76	0.73	
16					0.84	0.82	
18					0.92	0.91	
20					1.00	1.00	

Spacing Tension (f_s)

s_{act} (in.)	Dia.	¼	⅜	½	⅝	¾	IBC*
	E	1¼	2⅝	3½	4⅞	5¼	
	s_{cr}	8	8	8	8	8	
	s_{min}	4	4	4	4	4	
	f_{smin}	1.00	1.00	0.93	0.86	0.80	
4		1.00	1.00	0.93	0.86	0.80	
6		1.00	1.00	0.97	0.93	0.90	
8		1.00	1.00	1.00	1.00	1.00	

Spacing Shear (f_s)

s_{act} (in.)	Dia.	¼	⅜	½	⅝	¾	IBC*
	E	1¼	2⅝	3½	4⅞	5¼	
	s_{cr}	8	8	8	8	8	
	s_{min}	4	4	4	4	4	
	f_{smin}	1.00	1.00	1.00	1.00	1.00	
4		1.00	1.00	1.00	1.00	1.00	
6		1.00	1.00	1.00	1.00	1.00	
8		1.00	1.00	1.00	1.00	1.00	

Load Adjustment Factors for Carbon-Steel Strong-Bolt® 2 Wedge Anchors in Top-of-Wall Installation in 8" Grout-Filled CMU: Edge Distance and Spacing, Tension and Shear Loads

End Distance Tension (f_c)

s_{act} (in.)	Dia.	½	⅝	IBC*
	E	3½	4⅞	
	c_{cr}	12	12	
	c_{min}	4	4	
	f_{cmin}	1.00	1.00	
4		1.00	1.00	
6		1.00	1.00	
8		1.00	1.00	
10		1.00	1.00	
12		1.00	1.00	

End Distance Shear Perpendicular to Edge (f_c)

c_{act} (in.)	Dia.	½	⅝	IBC*
	E	3½	4⅞	
	c_{cr}	12	12	
	c_{min}	4	4	
	f_{cmin}	0.90	0.83	
4		0.90	0.83	
6		0.93	0.87	
8		0.95	0.92	
10		0.98	0.96	
12		1.00	1.00	

End Distance Shear Parallel to Edge (f_c)

c_{act} (in.)	Dia.	½	⅝	IBC*
	E	3½	4⅞	
	c_{cr}	12	12	
	c_{min}	4	4	
	f_{cmin}	0.53	0.50	
4		0.53	0.50	
6		0.65	0.63	
8		0.77	0.75	
10		0.88	0.88	
12		1.00	1.00	

Spacing Tension (f_s)

s_{act} (in.)	Dia.	½	⅝	IBC*
	E	3½	4⅞	
	s_{cr}	8	8	
	s_{min}	4	4	
	f_{smin}	0.93	0.86	
4		0.93	0.86	
6		0.97	0.93	
8		1.00	1.00	

Spacing Shear Perpendicular or Parallel to Edge (f_s)

s_{act} (in.)	Dia.	½	⅝	IBC*
	E	3½	4⅞	
	s_{cr}	8	8	
	s_{min}	4	4	
	f_{smin}	1.00	1.00	
4		1.00	1.00	
6		1.00	1.00	
8		1.00	1.00	

For footnotes, please see page 200.

* See page 12 for an explanation of the load table icons.

Wedge-All® Wedge Anchor

A non-bottom-bearing, wedge-style expansion anchor for use in solid concrete or grout-filled masonry. The Wedge-All® wedge anchor is available in carbon steel with zinc or mechanically galvanized coating, as well as Types 303/304 and Type 316 stainless steel. Threaded studs are set by tightening the nut to the specified torque. The Wedge-All is code listed for grout-filled masonry applications.

Features

- Code-listed under IBC/IRC for grout-filled CMU per ICC-ES ESR-1396
- One-piece, wrap-around clip ensures uniform holding capacity
- Threaded end is chamfered for ease of starting nut
- Available in a wide range of diameters and lengths

Codes: ICC-ES ESR-1396 (CMU); Florida FL-15730.7; FM 3017082 and 3131136; UL File Ex3605; Multiple DOT listings; meets the requirements of Federal Specification A-A-1923A, Type 4

Material: Carbon or stainless steel (Types 303/304; Type 316)

Coating: Carbon steel anchors are available zinc plated or mechanically galvanized



Installation

- Do not use an impact wrench to set or tighten anchors.
 - Caution:** Oversized holes in the base material will make it difficult to set the anchor and will reduce the anchor's load capacity.
1. Drill a hole in base material using a carbide drill bit the same diameter as the nominal diameter of the anchor to be installed. Drill the hole to the specified embedment depth, and blow it clean using compressed air. (Overhead installations need not be blown clean.) Alternatively, drill the hole deep enough to accommodate the embedment depth and the dust from drilling.
 2. Assemble the anchor with nut and washer so the top of the nut is flush with the top of the anchor. Place the anchor in the fixture, and drive it into the hole until the washer and nut are tight against the fixture.
 3. Tighten to the required installation torque.



Head Stamp
The head is stamped with the length identification letter.

Wedge-All® Anchor

Installation Sequence

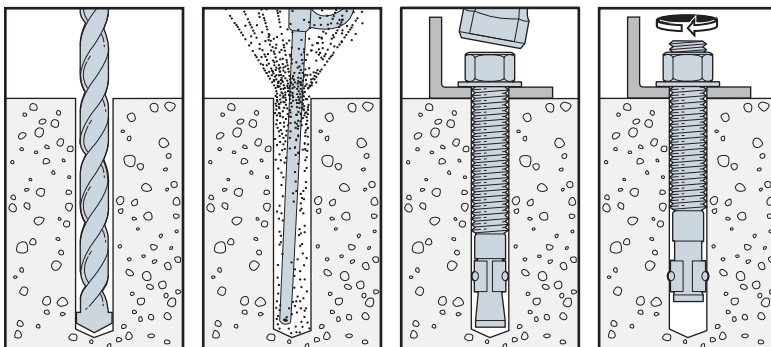

Wedge-All® Anchor Installation Data

Wedge-All Dia. (in.)	1/4	3/8	1/2	5/8	3/4	7/8	1	1 1/4
Drill Bit Size (in.)	1/4	3/8	1/2	5/8	3/4	7/8	1	1 1/4
Min. Fixture Hole (in.)	5/16	7/16	9/16	1 1/16	7/8	1	1 1/8	1 3/8
Wrench Size (in.)	7/16	9/16	3/4	15/16	1 1/8	1 5/16	1 1/2	1 7/8

Length Identification Head Marks on Wedge-All® Anchors (corresponds to length of anchor — inches).

Mark	A	B	C	D	E	F	G	H	I	J	K	L	M	N	O	P	Q	R	S	T	U	V	W	X	Y	Z
From	1 1/2	2	2 1/2	3	3 1/2	4	4 1/2	5	5 1/2	6	6 1/2	7	7 1/2	8	8 1/2	9	9 1/2	10	11	12	13	14	15	16	17	18
Up To But Not Including	2	2 1/2	3	3 1/2	4	4 1/2	5	5 1/2	6	6 1/2	7	7 1/2	8	8 1/2	9	9 1/2	10	11	12	13	14	15	16	17	18	19

Wedge-All® Wedge Anchor

Wedge-All® Anchor Product Data — Carbon Steel:
Zinc Plated and Mechanically Galvanized

Size (in.)	Zinc Plated Model No.	Mechanically Galvanized Model No.	Drill Bit Dia. (in.)	Thread Length (in.)	Quantity		
					Box	Carton	
1/4 x 1 3/4	—	WA25134MG	1/4	1 5/16	100	500	
1/4 x 2 1/4	—	WA25214MG		1 7/16	100	500	
1/4 x 3 1/4	—	WA25314MG		2 7/16	100	500	
3/8 x 2 1/4	WA37214	WA37214MG	3/8	1 1/8	50	250	
3/8 x 2 3/4	WA37234	WA37234MG		1 5/8	50	250	
3/8 x 3	WA37300	WA37300MG		1 7/8	50	250	
3/8 x 3 1/2	WA37312	WA37312MG		2 1/2	50	250	
3/8 x 3 3/4	WA37334	WA37334MG		2 5/8	50	250	
3/8 x 5	WA37500	WA37500MG		3 7/8	50	200	
3/8 x 7	WA37700	WA37700MG		5 7/8	50	200	
1/2 x 2 3/4	WA50234	WA50234MG		1/2	1 5/16	25	125
1/2 x 3 3/4	WA50334	WA50334MG	2 5/16		25	125	
1/2 x 4 1/4	WA50414	WA50414MG	2 13/16		25	100	
1/2 x 5 1/2	WA50512	WA50512MG	4 1/16		25	100	
1/2 x 7	WA50700	WA50700MG	4 9/16		25	100	
1/2 x 8 1/2	WA50812	WA50812MG	6		25	50	
1/2 x 10	WA50100	WA50100MG	6		25	50	
1/2 x 12	WA50120	WA50120MG	6		25	50	
5/8 x 3 1/2	WA62312	WA62312MG	5/8		1 7/8	20	80
5/8 x 4 1/2	WA62412	WA62412MG			2 7/8	20	80
5/8 x 5	WA62500	WA62500MG		3 3/8	20	80	
5/8 x 6	WA62600	WA62600MG		4 3/8	20	80	
5/8 x 7	WA62700	WA62700MG		5 3/8	20	80	
5/8 x 8 1/2	WA62812	WA62812MG		6	20	40	
5/8 x 10	WA62100	WA62100MG		6	10	20	
5/8 x 12	WA62120	WA62120MG		6	10	20	
3/4 x 4 1/4	WA75414	WA75414MG		3/4	2 3/8	10	40
3/4 x 4 3/4	WA75434	WA75434MG			2 7/8	10	40
3/4 x 5 1/2	WA75512	WA75512MG	3 3/8		10	40	
3/4 x 6 1/4	WA75614	WA75614MG	4 3/8		10	40	
3/4 x 7	WA75700	WA75700MG	5 1/8		10	40	
3/4 x 8 1/2	WA75812	WA75812MG	6		10	20	
3/4 x 10	WA75100	WA75100MG	6		10	20	
3/4 x 12	WA75120	WA75120MG	6		5	10	
7/8 x 6	WA87600	WA87600MG	7/8		2 1/8	5	20
7/8 x 8	WA87800	WA87800MG			2 1/8	5	10
7/8 x 10	WA87100	WA87100MG		2 1/8	5	10	
7/8 x 12	WA87120	WA87120MG		2 1/8	5	10	
1 x 6	WA16000	WA16000MG	1	2 1/4	5	20	
1 x 9	WA19000	WA19000MG		2 1/4	5	10	
1 x 12	WA11200	WA11200MG		2 1/4	5	10	
1 1/4 x 9	WA12590	—	1 1/4	2 3/4	5	10	
1 1/4 x 12	WA12512	—		2 3/4	5	10	

1. The published length is the overall length of the anchor. Allow one anchor diameter for the nut and washer thickness plus the fixture thickness when selecting the minimum length.

Material Specifications

Carbon Steel — Zinc Plated			
Component Materials			
Anchor Body	Nut	Washer	Clip
Material Meets minimum 70,000 psi tensile strength	Carbon Steel ASTM A 563, Grade A	Carbon Steel	Carbon Steel



Application:
Interior environment, low level of corrosion resistance. See page 316 for more corrosion information.

Material Specifications

Carbon Steel - Mechanically Galvanized ¹			
Component Materials			
Anchor Body	Nut	Washer	Clip
Material Meets minimum 70,000 psi tensile strength	Carbon Steel ASTM A 563, Grade A	Carbon Steel	Carbon Steel

1. Mechanical Galvanizing meets ASTM B695, Class 55, Type 1.



Application:
Exterior unpolluted environment, medium level of corrosion resistance. Well suited to humid environments. See page 316 for more corrosion information.

Wedge-All® Wedge Anchor

Wedge-All® Anchor Product Data - Stainless Steel

Size (in.)	Type 303/304 Stainless Model No. ²	Type 316 Stainless Model No.	Drill Bit Dia. (in.)	Thread Length (in.)	Quantity	
					Box	Carton
3/8 x 2 1/4	WA372144SS	WA372146SS	3/8	1 1/8	50	250
3/8 x 2 3/4	WA372344SS	WA372346SS		1 5/8	50	250
3/8 x 3	WA373004SS	WA373006SS		1 7/8	50	250
3/8 x 3 1/2	WA373124SS	WA373126SS		2 1/2	50	250
3/8 x 3 3/4	WA373344SS	WA373346SS		2 5/8	50	250
3/8 x 5	WA375004SS	WA375006SS		3 7/8	50	200
3/8 x 7	WA377004SS	WA377006SS		5 7/8	50	200
1/2 x 2 3/4	WA502344SS	WA502346SS	1/2	1 5/16	25	125
1/2 x 3 3/4	WA503344SS	WA503346SS		2 5/16	25	125
1/2 x 4 1/4	WA504144SS	WA504146SS		2 13/16	25	100
1/2 x 5 1/2	WA505124SS	WA505126SS		4 1/16	25	100
1/2 x 7	WA507004SS	WA507006SS		5 9/16	25	100
1/2 x 8 1/2	WA508124SS	WA508126SS		2	25	50
1/2 x 10	WA50100SS	WA501003SS		2	25	50
1/2 x 12	WA50120SS	WA501203SS		2	25	50
5/8 x 3 1/2	WA623124SS	WA623126SS		5/8	1 7/8	20
5/8 x 4 1/2	WA624124SS	WA624126SS	2 7/8		20	80
5/8 x 5	WA625004SS	WA625006SS	3 3/8		20	80
5/8 x 6	WA626004SS	WA626006SS	4 3/8		20	80
5/8 x 7	WA627004SS	WA627006SS	5 3/8		20	80
5/8 x 8 1/2	WA628124SS	WA628126SS	2		20	40
5/8 x 10	WA62100SS	WA621003SS	2		10	20
5/8 x 12	WA62120SS	WA621203SS	2		10	20
3/4 x 4 1/4	WA754144SS	WA754146SS	3/4	2 3/8	10	40
3/4 x 4 3/4	WA754344SS	WA754346SS		2 7/8	10	40
3/4 x 5 1/2	WA755124SS	WA755126SS		3 5/8	10	40
3/4 x 6 1/4	WA756144SS	WA756146SS		4 3/8	10	40
3/4 x 7	WA757004SS	WA757006SS		5 1/8	10	40
3/4 x 8 1/2	WA758124SS	WA758126SS		2 1/4	10	20
3/4 x 10	WA75100SS	WA751003SS		2 1/4	10	20
3/4 x 12	WA75120SS	WA751203SS		2 1/4	5	10
7/8 x 6	WA87600SS	WA876003SS	7/8	2 1/8	5	20
7/8 x 8	WA87800SS	WA878003SS		2 1/8	5	10
7/8 x 10	WA87100SS	WA871003SS		2 1/8	5	10
7/8 x 12	WA87120SS	—		2 1/8	5	10
1 x 6	WA16000SS	WA160003SS	1	2 1/4	5	20
1 x 9	WA19000SS	WA190003SS		2 1/4	5	10
1 x 12	WA11200SS	WA112003SS		2 1/4	5	10

1. The published length is the overall length of the anchor. Allow one anchor diameter for the nut and washer thickness plus the fixture thickness when selecting a length.
2. Anchors with the "SS" suffix in the model number are manufactured from Type-303 stainless steel; the remaining anchors (with the "4SS" suffix) are manufactured from Type 304 stainless steel. Types 303 and 304 stainless steel perform equally well in certain corrosive environments.

Material Specifications

Type 303/304 Stainless Steel ¹			
Component Materials			
Anchor Body	Nut	Washer	Clip
Type 303 or 304 Stainless Steel	Type 18-8 Stainless Steel	Type 18-8 Stainless Steel	Type 304 or 316 Stainless Steel

1. Types 303 and 304 stainless steels perform equally well in certain corrosive environments. Larger sizes are manufactured from Type 303.

Application:

Exterior environment, high level of corrosion resistance. Resistant to organic chemicals, many inorganic chemicals, mild atmospheric pollution and mild marine environments (not in direct contact with salt water). See page 316 for more corrosion information.

Material Specifications

Type 316 Stainless Steel ¹			
Component Materials			
Anchor Body	Nut	Washer	Clip
Type 316 Stainless Steel	Type 316 Stainless Steel	Type 316 Stainless Steel	Type 316 Stainless Steel

1. Type-316 stainless steel provides the greatest degree of corrosion resistance offered by Simpson Strong-Tie.

Application:

Exterior environment, high level of corrosion resistance. Resistant to chlorides, sulfuric acid compounds and direct contact with salt water. See page 316 for more corrosion information.



Wedge-All® Design Information — Concrete



Carbon-Steel Wedge-All® Allowable Tension Loads in Normal-Weight Concrete

Size in. (mm)	Embed. Depth in. (mm)	Critical Edge Dist. in. (mm)	Critical Spacing in. (mm)	Tension Load						Install. Torque ft.-lb. (N-m)	
				$f'_c \geq 2,000$ psi (13.8 MPa) Concrete			$f'_c \geq 3,000$ psi (20.7 MPa) Concrete		$f'_c \geq 4,000$ psi (27.6 MPa) Concrete		
				Ultimate lb. (kN)	Std. Dev. lb. (kN)	Allowable lb. (kN)	Allowable lb. (kN)	Ultimate lb. (kN)	Std. Dev. lb. (kN)		Allowable lb. (kN)
¼ (6.4)	1½ (29)	2½ (64)	1½ (41)	680 (3.0)	167 (0.7)	170 (0.8)	205 (0.9)	960 (4.3)	233 (1.0)	240 (1.1)	8 (10.8)
	2¼ (57)	2½ (64)	3½ (79)	1,920 (8.5)	286 (1.3)	480 (2.1)	530 (2.4)	2,320 (10.3)	105 (0.5)	580 (2.6)	
⅜ (9.5)	1¾ (44)	3¼ (95)	2¾ (60)	1,560 (6.9)	261 (1.2)	390 (1.7)	555 (2.5)	2,880 (12.8)	588 (2.6)	720 (3.2)	30 (40.7)
	2⅝ (67)	3¼ (95)	3⅝ (92)	3,360 (14.9)	464 (2.1)	840 (3.7)	1,100 (4.9)	5,440 (24.2)	553 (2.5)	1,360 (6.0)	
	3⅝ (86)	3¼ (95)	4¼ (121)	3,680 (16.4)	585 (2.6)	920 (4.1)	1,140 (5.1)	5,440 (24.2)	318 (1.4)	1,360 (6.0)	
½ (12.7)	2¼ (57)	5 (127)	3⅝ (79)	3,280 (14.6)	871 (3.9)	820 (3.6)	1,070 (4.8)	5,280 (23.5)	849 (3.8)	1,320 (5.9)	60 (81.3)
	3⅝ (86)	5 (127)	4¼ (121)	6,040 (26.9)	654 (2.9)	1,510 (6.7)	1,985 (8.8)	9,840 (43.8)	1,303 (5.8)	2,460 (10.9)	
	4½ (114)	5 (127)	6¼ (159)	6,960 (31.0)	839 (3.7)	1,740 (7.7)	2,350 (10.5)	11,840 (52.7)	2,462 (11.0)	2,960 (13.2)	
⅝ (15.9)	2¾ (70)	6¼ (159)	3⅝ (98)	4,520 (20.1)	120 (0.5)	1,130 (5.0)	1,640 (7.3)	8,600 (38.3)	729 (3.2)	2,150 (9.6)	90 (122.0)
	4½ (114)	6¼ (159)	6¼ (159)	8,200 (36.5)	612 (2.7)	2,050 (9.1)	2,990 (13.3)	15,720 (69.9)	1,224 (5.4)	3,930 (17.5)	
	5½ (140)	6¼ (159)	7¾ (197)	8,200 (36.5)	639 (2.8)	2,050 (9.1)	2,990 (13.3)	15,720 (69.9)	1,116 (5.0)	3,930 (17.5)	
¾ (19.1)	3⅝ (86)	7½ (191)	4¼ (121)	6,760 (30.1)	1,452 (6.5)	1,690 (7.5)	2,090 (9.3)	9,960 (44.3)	1,324 (5.9)	2,490 (11.1)	150 (203.4)
	5 (127)	7½ (191)	7 (178)	10,040 (44.7)	544 (2.4)	2,510 (11.2)	3,225 (14.3)	15,760 (70.1)	1,550 (6.9)	3,940 (17.5)	
	6¾ (171)	7½ (191)	9½ (241)	10,040 (44.7)	1,588 (7.1)	2,510 (11.2)	3,380 (15.0)	17,000 (75.6)	1,668 (7.4)	4,250 (18.9)	
⅞ (22.2)	3⅝ (98)	8¼ (222)	5⅝ (137)	7,480 (33.3)	821 (3.7)	1,870 (8.3)	2,275 (10.1)	10,720 (47.7)	1,253 (5.6)	2,680 (11.9)	200 (271.2)
	7⅝ (200)	8¼ (222)	11 (279)	17,040 (75.8)	1,566 (7.0)	4,260 (18.9)	4,670 (20.8)	20,320 (90.4)	2,401 (10.7)	5,080 (22.6)	
1 (25.4)	4½ (114)	10 (254)	6¼ (159)	15,400 (68.5)	2,440 (10.9)	3,850 (17.1)	3,885 (17.3)	15,680 (69.7)	1,876 (8.3)	3,920 (17.4)	300 (406.7)
	9 (229)	10 (254)	12⅝ (321)	20,760 (92.3)	3,116 (13.9)	5,190 (23.1)	6,355 (28.3)	30,080 (133.8)	1,612 (7.2)	7,520 (33.5)	
1¼ (31.8)	5⅝ (143)	12½ (318)	7⅝ (200)	15,160 (67.4)	1,346 (6.0)	3,790 (16.9)	4,990 (22.2)	24,760 (110.1)	625 (2.8)	6,190 (27.5)	400 (542.3)
	9½ (241)	12½ (318)	13¼ (337)	20,160 (89.7)	3,250 (14.5)	5,040 (22.4)	8,635 (38.4)	48,920 (217.6)	1,693 (7.5)	12,230 (54.4)	

1. The allowable loads listed are based on a safety factor of 4.0.
2. Refer to allowable load-adjustment factors for edge distance and spacing on pages 172 and 174.
3. Drill bit diameter used in base material corresponds to nominal anchor diameter.
4. Allowable loads may be linearly interpolated between concrete strengths listed.
5. The minimum concrete thickness is 1½ times the embedment depth.

Wedge-All® Design Information — Concrete



Carbon-Steel Wedge-All® Allowable Shear Loads in Normal-Weight Concrete

Size in. (mm)	Embed. Depth in. (mm)	Critical Edge Dist. in. (mm)	Critical Spacing in. (mm)	Shear Load					Install. Torque ft.-lb. (N-m)
				$f'_c \geq 2,000$ psi (13.8 MPa) Concrete			$f'_c \geq 3,000$ psi (20.7 MPa) Concrete	$f'_c \geq 4,000$ psi (27.6 MPa) Concrete	
				Ultimate lb. (kN)	Std. Dev. lb. (kN)	Allowable lb. (kN)	Allowable lb. (kN)	Allowable lb. (kN)	
¼ (6.4)	1½ (29)	2½ (64)	1½ (41)	920 (4.1)	47 (0.2)	230 (1.0)	230 (1.0)	230 (1.0)	8 (10.8)
	2¼ (57)	2½ (64)	3½ (79)	—	—	230 (1.0)	230 (1.0)	230 (1.0)	
⅜ (9.5)	1¾ (44)	3¼ (95)	2¾ (60)	2,280 (10.1)	96 (0.4)	570 (2.5)	570 (2.5)	570 (2.5)	30 (40.7)
	2⅝ (67)	3¼ (95)	3⅝ (92)	4,220 (18.8)	384 (1.7)	1,055 (4.7)	1,055 (4.7)	1,055 (4.7)	
	3⅝ (86)	3¼ (95)	4¼ (121)	—	—	1,055 (4.7)	1,055 (4.7)	1,055 (4.7)	
½ (12.7)	2¼ (57)	5 (127)	3½ (79)	6,560 (29.2)	850 (3.8)	1,345 (6.0)	1,485 (6.6)	1,625 (7.2)	60 (81.3)
	3⅝ (86)	5 (127)	4¾ (121)	8,160 (36.3)	880 (3.9)	1,675 (7.5)	1,850 (8.2)	2,020 (9.0)	
	4½ (114)	5 (127)	6¼ (159)	—	—	1,675 (7.5)	1,850 (8.2)	2,020 (9.0)	
⅝ (15.9)	2¾ (70)	6¼ (159)	3¾ (98)	8,720 (38.8)	1,699 (7.6)	1,620 (7.2)	1,900 (8.5)	2,180 (9.7)	90 (122.0)
	4½ (114)	6¼ (159)	6¼ (159)	12,570 (55.9)	396 (1.8)	2,330 (10.4)	2,740 (12.2)	3,145 (14.0)	
	5½ (140)	6¼ (159)	7¾ (197)	—	—	2,330 (10.4)	2,740 (12.2)	3,145 (14.0)	
¾ (19.1)	3⅝ (86)	7½ (191)	4¾ (121)	11,360 (50.5)	792 (3.5)	2,840 (12.6)	2,840 (12.6)	2,840 (12.6)	150 (203.4)
	5 (127)	7½ (191)	7 (178)	18,430 (82.0)	1,921 (8.5)	4,610 (20.5)	4,610 (20.5)	4,610 (20.5)	
	6¾ (171)	7½ (191)	9½ (241)	—	—	4,610 (20.5)	4,610 (20.5)	4,610 (20.5)	
⅞ (22.2)	3⅝ (98)	8¾ (222)	5⅝ (137)	13,760 (61.2)	2,059 (9.2)	3,440 (15.3)	3,440 (15.3)	3,440 (15.3)	200 (271.2)
	7⅝ (200)	8¾ (222)	11 (279)	22,300 (99.2)	477 (2.1)	5,575 (24.8)	5,575 (24.8)	5,575 (24.8)	
1 (25.4)	4½ (114)	10 (254)	6¼ (159)	22,519 (100.2)	1,156 (5.1)	5,730 (25.5)	5,730 (25.5)	5,730 (25.5)	300 (406.7)
	9 (229)	10 (254)	12⅝ (321)	25,380 (112.9)	729 (3.2)	6,345 (28.2)	6,345 (28.2)	6,345 (28.2)	
1¼ (31.8)	5⅝ (143)	12½ (318)	7¾ (200)	29,320 (130.4)	2,099 (9.3)	7,330 (32.6)	7,330 (32.6)	7,330 (32.6)	400 (542.3)
	9½ (241)	12½ (318)	13¼ (337)	—	—	7,330 (32.6)	7,330 (32.6)	7,330 (32.6)	

1. The allowable loads listed are based on a safety factor of 4.0.
2. Refer to allowable load-adjustment factors for spacing and edge distance on pages 172, 173 and 175.
3. Drill bit diameter used in base material corresponds to nominal anchor diameter.
4. Allowable loads may be linearly interpolated between concrete strengths listed.
5. The minimum concrete thickness is 1½ times the embedment depth.

* See page 12 for an explanation of the load table icons.

Wedge-All® Design Information — Concrete



Stainless-Steel Wedge-All® Allowable Tension Loads in Normal-Weight Concrete

Size in. (mm)	Embed. Depth in. (mm)	Critical Edge Dist. in. (mm)	Critical Spacing in. (mm)	Allowable Tension Load lb. (kN)			Install. Torque ft.-lb. (N-m)
				$f'_c \geq 2,000$ psi (13.8 MPa) Concrete	$f'_c \geq 3,000$ psi (20.7 MPa) Concrete	$f'_c \geq 4,000$ psi (27.6 MPa) Concrete	
¼ (6.4)	1⅞ (29)	2½ (64)	1⅝ (41)	155 (0.7)	185 (0.8)	215 (1.0)	8 (10.8)
	2¼ (57)	2½ (64)	3⅞ (79)	430 (1.9)	475 (2.1)	520 (2.3)	
⅜ (9.5)	1¾ (44)	3¾ (95)	2⅝ (60)	350 (1.6)	500 (2.2)	650 (2.9)	30 (40.7)
	2⅝ (67)	3¾ (95)	3⅝ (92)	755 (3.4)	990 (4.4)	1,225 (5.4)	
	3⅝ (86)	3¾ (95)	4¾ (121)	830 (3.7)	1,025 (4.6)	1,225 (5.4)	
½ (12.7)	2¼ (57)	5 (127)	3⅞ (79)	740 (3.3)	965 (4.3)	1,190 (5.3)	60 (81.3)
	3⅝ (86)	5 (127)	4¾ (121)	1,360 (6.0)	1,785 (7.9)	2,215 (9.9)	
	4½ (114)	5 (127)	6¼ (159)	1,565 (7.0)	2,115 (9.4)	2,665 (11.9)	
⅝ (15.9)	2¾ (70)	6¼ (159)	3⅞ (98)	1,015 (4.5)	1,475 (6.6)	1,935 (8.6)	90 (122.0)
	4½ (114)	6¼ (159)	6¼ (159)	1,845 (8.2)	2,690 (12.0)	3,535 (15.7)	
	5½ (140)	6¼ (159)	7¾ (197)	1,845 (8.2)	2,690 (12.0)	3,535 (15.7)	
¾ (19.1)	3⅝ (86)	7½ (191)	4¾ (121)	1,520 (6.8)	1,880 (8.4)	2,240 (10.0)	150 (203.4)
	5 (127)	7½ (191)	7 (178)	2,260 (10.1)	2,905 (12.9)	3,545 (15.8)	
	6¾ (171)	7½ (191)	9½ (241)	2,260 (10.1)	3,040 (13.5)	3,825 (17.0)	
⅞ (22.2)	3⅞ (98)	8¾ (222)	5⅝ (137)	1,685 (7.5)	2,050 (9.1)	2,410 (10.7)	200 (271.2)
	7⅞ (200)	8¾ (222)	11 (279)	3,835 (17.1)	4,205 (18.7)	4,570 (20.3)	
1 (25.4)	4½ (114)	10 (254)	6¼ (159)	3,465 (15.4)	3,495 (15.5)	3,530 (15.7)	300 (406.7)
	9 (229)	10 (254)	12⅝ (321)	4,670 (20.8)	5,720 (25.4)	6,770 (30.1)	
1¼ (31.8)	5⅝ (143)	12½ (318)	7⅞ (200)	3,410 (15.2)	4,490 (20.0)	5,570 (24.8)	400 (542.3)
	9½ (241)	12½ (318)	13¼ (337)	4,535 (20.2)	7,770 (34.6)	11,005 (49.0)	

1. The allowable loads listed are based on a safety factor of 4.0.
2. Refer to allowable load-adjustment factors for edge distance and spacing on pages 172 and 174.
3. Drill bit diameter used in base material corresponds to nominal anchor diameter.
4. Allowable loads may be linearly interpolated between concrete strengths listed.
5. The minimum concrete thickness is 1½ times the embedment depth.

Wedge-All® Design Information — Concrete

Stainless-Steel Wedge-All® Allowable Shear Loads in Normal-Weight Concrete



Size in. (mm)	Embed. Depth in. (mm)	Critical Edge Dist. in. (mm)	Critical Spacing in. (mm)	Allowable Shear Load lb. (kN)			Install. Torque ft.-lb. (N-m)
				$f'_c \geq 2,000$ psi (13.8 MPa) Concrete	$f'_c \geq 3,000$ psi (20.7 MPa) Concrete	$f'_c \geq 4,000$ psi (27.6 MPa) Concrete	
1/4 (6.4)	1 1/8 (29)	2 1/2 (64)	1 5/8 (41)	265 (1.2)	265 (1.2)	265 (1.2)	8 (10.8)
	2 1/4 (57)	2 1/2 (64)	3 1/8 (79)	265 (1.2)	265 (1.2)	265 (1.2)	
3/8 (9.5)	1 3/4 (44)	3 3/4 (95)	2 3/8 (60)	655 (2.9)	655 (2.9)	655 (2.9)	30 (40.7)
	2 5/8 (67)	3 3/4 (95)	3 5/8 (92)	1,215 (5.4)	1,215 (5.4)	1,215 (5.4)	
	3 3/8 (86)	3 3/4 (95)	4 3/4 (121)	1,215 (5.4)	1,215 (5.4)	1,215 (5.4)	
1/2 (12.7)	2 1/4 (57)	5 (127)	3 1/8 (79)	1,545 (6.9)	1,710 (7.6)	1,870 (8.3)	60 (81.3)
	3 3/8 (86)	5 (127)	4 3/4 (121)	1,925 (8.6)	2,130 (9.5)	2,325 (10.3)	
	4 1/2 (114)	5 (127)	6 1/4 (159)	1,925 (8.6)	2,130 (9.5)	2,325 (10.3)	
5/8 (15.9)	2 3/4 (70)	6 1/4 (159)	3 7/8 (98)	1,865 (8.3)	2,185 (9.7)	2,505 (11.1)	90 (122.0)
	4 1/2 (114)	6 1/4 (159)	6 1/4 (159)	2,680 (11.9)	3,150 (14.0)	3,615 (16.1)	
	5 1/2 (140)	6 1/4 (159)	7 3/4 (197)	2,680 (11.9)	3,150 (14.0)	3,615 (16.1)	
3/4 (19.1)	3 3/8 (86)	7 1/2 (191)	4 3/4 (121)	3,265 (14.5)	3,265 (14.5)	3,265 (14.5)	150 (203.4)
	5 (127)	7 1/2 (191)	7 (178)	5,300 (23.6)	5,300 (23.6)	5,300 (23.6)	
	6 3/4 (171)	7 1/2 (191)	9 1/2 (241)	5,300 (23.6)	5,300 (23.6)	5,300 (23.6)	
7/8 (22.2)	3 7/8 (98)	8 3/4 (222)	5 5/8 (137)	3,955 (17.6)	3,955 (17.6)	3,955 (17.6)	200 (271.2)
	7 7/8 (200)	8 3/4 (222)	11 (279)	6,410 (28.5)	6,410 (28.5)	6,410 (28.5)	
1 (25.4)	4 1/2 (114)	10 (254)	6 1/4 (159)	6,590 (29.3)	6,590 (29.3)	6,590 (29.3)	300 (406.7)
	9 (229)	10 (254)	12 5/8 (321)	7,295 (32.4)	7,295 (32.4)	7,295 (32.4)	
1 1/4 (31.8)	5 5/8 (143)	12 1/2 (318)	7 7/8 (200)	8,430 (37.5)	8,430 (37.5)	8,430 (37.5)	400 (542.3)
	9 1/2 (241)	12 1/2 (318)	13 1/4 (337)	8,430 (37.5)	8,430 (37.5)	8,430 (37.5)	

- The allowable loads listed are based on a safety factor of 4.0.
- Refer to allowable load-adjustment factors for spacing and edge distance on pages 172, 173 and 175.
- Drill bit diameter used in base material corresponds to nominal anchor diameter.
- Allowable loads may be linearly interpolated between concrete strengths listed.
- The minimum concrete thickness is 1 1/2 times the embedment depth.

* See page 12 for an explanation of the load table icons.

Wedge-All® Design Information — Concrete and Masonry

Carbon-Steel Wedge-All® Allowable Tension Loads in Sand-Lightweight Concrete over Metal Deck



Size in. (mm)	Embed. Depth in. (mm)	Critical Edge Dist. in. (mm)	Critical Spacing in. (mm)	Tension Load (Install in Concrete)			Tension Load (Install through Metal Deck)			Install. Torque ft.-lb. (N-m)
				$f'_c \geq 3,000$ psi (20.7 MPa) Concrete			$f'_c \geq 3,000$ psi (20.7 MPa) Concrete			
				Ultimate lb. (kN)	Std. Dev. lb. (kN)	Allow. lb. (kN)	Ultimate lb. (kN)	Std. Dev. lb. (kN)	Allow. lb. (kN)	
1/4 (6.4)	1 1/2 (38)	3% (86)	2 3/4 (70)	—	—	—	1,440 (6.4)	167 (0.7)	360 (1.6)	—
1/2 (12.7)	2 1/4 (57)	6 3/4 (171)	4 1/8 (105)	3,880 (17.3)	228 (1.0)	970 (4.3)	3,860 (17.2)	564 (2.5)	965 (4.3)	60 (81.3)
5/8 (15.9)	2 3/4 (70)	8 3/8 (213)	5 (127)	5,920 (26.3)	239 (1.1)	1,480 (6.6)	5,220 (23.2)	370 (1.6)	1,305 (5.8)	90 (122.0)
3/4 (19.1)	3 3/8 (>86)	10 (254)	6 1/8 (156)	7,140 (31.8)	537 (2.4)	1,785 (7.9)	6,600 (29.4)	903 (4.0)	1,650 (7.3)	150 (203.4)

See notes 1–7 below.

Carbon-Steel Wedge-All® Allowable Shear Loads in Sand-Lightweight Concrete over Metal Deck



Size in. (mm)	Embed. Depth in. (mm)	Critical Edge Dist. in. (mm)	Critical Spacing in. (mm)	Shear Load (Install in Concrete)			Shear Load (Install through Metal Deck)			Install. Torque ft.-lb. (N-m)
				$f'_c \geq 3,000$ psi (20.7 MPa) Concrete			$f'_c \geq 3,000$ psi (20.7 MPa) Concrete			
				Ultimate lb. (kN)	Std. Dev. lb. (kN)	Allow. lb. (kN)	Ultimate lb. (kN)	Std. Dev. lb. (kN)	Allow. lb. (kN)	
1/4 (6.4)	1 1/2 (38)	3% (86)	2 3/4 (70)	—	—	—	1,660 (7.4)	627 (2.8)	415 (1.8)	—
1/2 (12.7)	2 1/4 (57)	6 3/4 (171)	4 1/8 (105)	5,575 (24.8)	377 (1.7)	1,395 (6.2)	7,260 (32.3)	607 (2.7)	1,815 (8.1)	60 (81.3)
5/8 (15.9)	2 3/4 (70)	8 3/8 (213)	5 (127)	8,900 (39.6)	742 (3.3)	2,225 (9.9)	8,560 (38.1)	114 (0.5)	2,140 (9.5)	90 (122.0)
3/4 (19.1)	3 3/8 (86)	10 (254)	6 1/8 (156)	10,400 (46.3)	495 (2.2)	2,600 (11.6)	11,040 (49.1)	321 (1.4)	2,760 (12.3)	150 (203.4)

- The allowable loads listed are based on a safety factor of 4.0.
- Refer to allowable load-adjustment factors for edge distance on page 176.
- 100% of the allowable load is permitted at critical spacing. Loads at reduced spacing have not been determined.
- Drill bit diameter used in base material corresponds to nominal anchor diameter.
- The minimum concrete thickness is 1 1/2 times the embedment depth.
- Metal deck must be minimum 20 gauge.
- Wedge-All anchors installed in the bottom flute of the steel deck must have a minimum allowable edge distance of 1 1/2" from the inclined edge of the bottom flute.

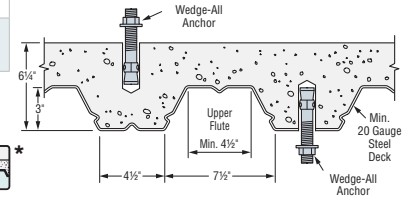

Lightweight Concrete on Metal Deck

Carbon-Steel Wedge-All® Allowable Tension and Shear Loads in Grout-Filled CMU



Size in. (mm)	Embed. Depth in. (mm)	Critical Edge Dist. in. (mm)	Critical End Dist. in. (mm)	Critical Spacing in. (mm)	8" Grout-Filled CMU Allowable Load Based on CMU Strength						Install. Torque ft.-lb. (N-m)
					Tension Load			Shear Load			
					Ultimate lb. (kN)	Std. Dev. lb. (kN)	Allow. lb. (kN)	Ultimate lb. (kN)	Std. Dev. lb. (kN)	Allow. lb. (kN)	
Anchor Installed on the Face of the CMU Wall at Least 1 1/4 inch Away from Head Joint (See Figure)											
3/8 (9.5)	2 5/8 (67)	10 1/2 (267)	10 1/2 (267)	10 1/2 (267)	1,700 (7.6)	129 (0.6)	340 (1.5)	3,360 (14.9)	223 (1.0)	670 (3.0)	30 (40.7)
1/2 (12.7)	3 1/2 (89)	14 (356)	14 (356)	14 (356)	2,120 (9.4)	129 (0.6)	425 (1.9)	5,360 (23.8)	617 (2.7)	1,070 (4.8)	35 (47.4)
5/8 (15.9)	4 3/8 (111)	17 1/2 (445)	17 1/2 (445)	17 1/2 (445)	3,120 (13.9)	342 (1.5)	625 (2.8)	8,180 (36.4)	513 (2.3)	1,635 (7.3)	55 (74.5)
3/4 (19.1)	5 1/4 (133)	21 (533)	21 (533)	21 (533)	4,320 (19.2)	248 (1.1)	865 (3.8)	10,160 (45.2)	801 (3.6)	2,030 (9.0)	120 (162.6)

- The tabulated allowable loads are based on a safety factor of 5.0 for installations under the IBC and IRC.
- Listed loads may be applied to installations on the face of the CMU wall at least 1 1/4 inch away from headjoints.
- Values for 8-inch wide concrete masonry units (CMU) with a minimum specified compressive strength of masonry, f'_m , at 28 days is 1,500 psi.
- Embedment depth is measured from the outside face of the concrete masonry unit.
- Drill bit diameter used in base material corresponds to nominal anchor diameter.
- Allowable loads may be increased 33 1/3% for short-term loading due to wind and seismic forces, where permitted by code.
- Tension and shear loads for the Wedge-All® anchor may be combined using the parabolic interaction equation ($n=3$).
- Refer to allowable load-adjustment factors for edge distance on page 176.

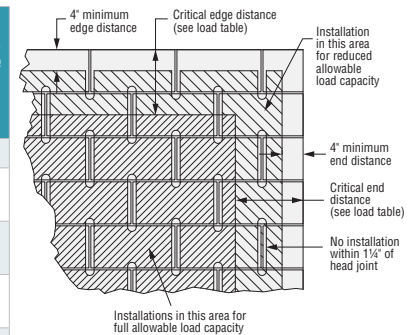

Shaded area = Placement for Full and Reduced Allowable Load Capacity in Grout-Filled CMU

C-A-2016 © 2015 SIMPSON STRONG-TIE COMPANY, INC.

* See page 12 for an explanation of the load table icons.

Mechanical Anchors

Wedge-All® Design Information — Concrete

Allowable Load-Adjustment Factors for Carbon-Steel and Stainless-Steel Wedge-All® Anchors in Normal-Weight Concrete: Edge Distance, Tension and Shear Loads

How to use these charts:

1. The following tables are for reduced edge distance.
2. Locate the anchor size to be used for either a tension and/or shear load application.
3. Locate the edge distance (C_{act}) at which the anchor is to be installed.
4. The load adjustment factor (f_c) is the intersection of the row and column.
5. Multiply the allowable load by the applicable load adjustment factor.
6. Reduction factors for multiple edges are multiplied together.

Edge Distance Tension (f_c)

Edge Dist. C_{act} (in.)	Size	¼	⅜	½	⅝	¾	⅞	1	1¼
	C_{cr}	2½	3¾	5	6¼	7½	8¾	10	12½
	C_{min}	1	1½	2	2½	3	3½	4	5
	f_{cmin}	0.70	0.70	0.70	0.70	0.70	0.70	0.70	0.70
1		0.70							
1½		0.80	0.70						
2		0.90	0.77	0.70					
2½		1.00	0.83	0.75	0.70				
3			0.90	0.80	0.74	0.70			
3½			0.97	0.85	0.78	0.73	0.70		
3¾			1.00	0.88	0.80	0.75	0.71		
4				0.90	0.82	0.77	0.73	0.70	
4½				0.95	0.86	0.80	0.76	0.73	
5				1.00	0.90	0.83	0.79	0.75	0.70
5½					0.94	0.87	0.81	0.78	0.72
6					0.98	0.90	0.84	0.80	0.74
6¼					1.00	0.92	0.86	0.81	0.75
6½						0.93	0.87	0.83	0.76
7						0.97	0.90	0.85	0.78
7½						1.00	0.93	0.88	0.80
8							0.96	0.90	0.82
8½							0.99	0.93	0.84
8¾							1.00	0.94	0.85
10								1.00	0.90
12½									1.00
15									

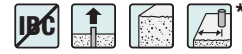

See notes below.

Edge Distance Shear (f_c) (Shear Applied Perpendicular to Edge)

Edge Dist. C_{act} (in.)	Size	¼	⅜	½	⅝	¾	⅞	1	1¼
	C_{cr}	2½	3¾	5	6¼	7½	8¾	10	12½
	C_{min}	1	1½	2	2½	3	3½	4	5
	f_{cmin}	0.30	0.30	0.30	0.30	0.30	0.30	0.30	0.30
1		0.30							
1½		0.53	0.30						
2		0.77	0.46	0.30					
2½		1.00	0.61	0.42	0.30				
3			0.77	0.53	0.39	0.30			
3½			0.92	0.65	0.49	0.38	0.30		
3¾			1.00	0.71	0.53	0.42	0.33		
4				0.77	0.58	0.46	0.37	0.30	
4½				0.88	0.67	0.53	0.43	0.36	
5				1.00	0.77	0.61	0.50	0.42	0.30
5½					0.86	0.69	0.57	0.48	0.35
6					0.95	0.77	0.63	0.53	0.39
6¼					1.00	0.81	0.67	0.56	0.42
6½						0.84	0.70	0.59	0.44
7						0.92	0.77	0.65	0.49
7½						1.00	0.83	0.71	0.53
8							0.90	0.77	0.58
8½							0.97	0.83	0.63
8¾							1.00	0.85	0.65
10								1.00	0.77
12½									1.00
15									



1. C_{act} = actual edge distance at which anchor is installed (inches).
2. C_{cr} = critical edge distance for 100% load (inches).
3. C_{min} = minimum edge distance for reduced load (inches).
4. f_c = adjustment factor for allowable load at actual edge distance.
5. $f_{c_{cr}}$ = adjustment factor for allowable load at critical edge distance. $f_{c_{cr}}$ is always = 1.00.
6. $f_{c_{min}}$ = adjustment factor for allowable load at minimum edge distance.
7. $f_c = f_{c_{min}} + [(1 - f_{c_{min}}) (C_{act} - C_{min}) / (C_{cr} - C_{min})]$.

Load-Adjustment Factors for Reduced Spacing:

Critical spacing is listed in the load tables. No adjustment in load is required when the anchors are spaced at critical spacing. No additional testing has been performed to determine the adjustment factors for spacing dimensions less than those listed in the load tables.

* See page 12 for an explanation of the load table icons.

Wedge-All® Design Information — Concrete

Allowable Load-Adjustment Factors for Carbon-Steel and Stainless-Steel Wedge-All® Anchors in Normal-Weight Concrete: Edge Distance and Shear Load Applied Parallel to Edge

How to use these charts:

1. The following tables are for reduced edge distance.
2. Locate the anchor size to be used for a shear load application.
3. Locate the edge distance ($c_{act||}$) at which the anchor is to be installed.
4. The load adjustment factor ($\phi_{c||}$) is the intersection of the row and column.
5. Multiply the allowable load by the applicable load adjustment factor.
6. Reduction factors for multiple edges are multiplied together.

Edge Distance Shear ($f_{c||}$) (Shear Applied Parallel to Edge with End Distance $\geq ED_{min}$)

Edge Dist. $c_{act }$ (in.)	Size	1/4	3/8	1/2	5/8	3/4	7/8	1	1 1/4
	E	2 1/4	3 3/8	4 1/2	5 1/2	6 3/4	7 7/8	9	9 1/2
	ED_{min}	9	13 1/2	18	22	27	31 1/2	36	38
	c_{crit}	2 1/2	3 3/4	5	6 1/4	7 1/2	8 3/4	10	12 1/2
	c_{min}	1	1 1/2	2	2 1/2	3	3 1/2	4	5
	f_{cmin}	1.00	0.93	0.70	0.62	0.62	0.62	0.62	0.62
1		1.00							
1 1/2		1.00	0.93						
2		1.00	0.95	0.70					
2 1/2		1.00	0.96	0.75	0.62				
3			0.98	0.80	0.67	0.62			
3 1/2			0.99	0.85	0.72	0.66	0.62		
4			1.00	0.90	0.77	0.70	0.66	0.62	
5				1.00	0.87	0.79	0.73	0.68	0.62
6					0.97	0.87	0.80	0.75	0.67
7					1.00	0.96	0.87	0.81	0.72
8						1.00	0.95	0.87	0.77
9							1.00	0.94	0.82
10								1.00	0.87
11									0.92
12									0.97
13									1.00

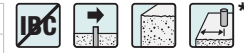

1. Table is not applicable to anchors with $ED < ED_{min}$. Factors from this table may not be combined with load-adjustment factors for shear loads applied perpendicular to edge.
2. $c_{act||}$ = actual edge distance (measured perpendicular to direction of shear load) at which anchor is installed (inches).
3. $c_{crit||}$ = critical edge distance (measured perpendicular to direction of shear load) for 100% load (inches).
4. $c_{min||}$ = minimum edge distance (measured perpendicular to direction of shear load) for reduced load (inches).
5. ED = actual end distance (measured parallel to direction of shear load) at which anchor is installed (inches).
6. ED_{min} = minimum edge distance (measured parallel to direction of shear load).
7. $f_{c||}$ = adjustment factor for allowable load at actual edge distance.
8. $f_{crit||}$ = adjustment factor for allowable load at critical edge distance. $f_{crit||}$ is always = 1.00.
9. $f_{cmin||}$ = adjustment factor for allowable load at minimum edge distance.
10. $f_{c||} = f_{cmin||} + [(1 - f_{cmin||}) (c_{act||} - c_{min||}) / (c_{crit||} - c_{min||})]$.

C-A-2016 © 2015 SIMPSON STRONG-TIE COMPANY INC.

* See page 12 for an explanation of the load table icons.

Wedge-All® Design Information — Concrete

Allowable Load-Adjustment Factors for Carbon-Steel and Stainless-Steel Wedge-All® Anchors in Normal-Weight Concrete: Spacing, Tension Loads

How to use these charts:

1. The following tables are for reduced spacing.
2. Locate the anchor size to be used for a tension load application.
3. Locate the anchor embedment (E) used for a tension load application.
4. Locate the spacing (s_{act}) at which the anchor is to be installed.
5. The load adjustment factor (f_s) is the intersection of the row and column.
6. Multiply the allowable load by the applicable load adjustment factor.
7. Reduction factors for multiple spacings are multiplied together.

Spacing Tension (f_s)

s_{act} (in.)	Dia.	¼				⅜		½			⅝		
	E	1⅞	2¼	1¾	2⅝	3%	2¼	3%	4½	2¾	4½	5½	
	s_{cr}	1%	3⅞	2%	3⅝	4%	3⅞	4%	6¼	3%	6¼	7¾	
	s_{min}	⅝	1⅞	7/8	1%	1%	1⅞	1%	2¼	1%	2¼	2¾	
	f_{smin}	0.43	0.70	0.43	0.43	0.70	0.43	0.43	0.70	0.43	0.43	0.70	
¾		0.50											
1		0.64		0.48									
1¼		0.79	0.72	0.57			0.47						
1½		0.93	0.76	0.67	0.46		0.54			0.46			
1¾		1.00	0.79	0.76	0.53	0.70	0.61	0.43		0.52			
2			0.83	0.86	0.59	0.73	0.68	0.48		0.57			
2¼			0.87	0.95	0.65	0.75	0.75	0.53	0.70	0.63	0.43		
2½			0.91	1.00	0.72	0.78	0.82	0.57	0.72	0.69	0.47		
2¾			0.94		0.78	0.80	0.89	0.62	0.74	0.74	0.50	0.70	
3			0.98		0.84	0.83	0.96	0.67	0.76	0.80	0.54	0.72	
3½			1.00		0.97	0.88	1.00	0.76	0.79	0.91	0.61	0.75	
4					1.00	0.93		0.86	0.83	1.00	0.68	0.78	
4½						0.98		0.95	0.87		0.75	0.81	
5						1.00		1.00	0.91		0.82	0.84	
6									0.98		0.96	0.90	
7									1.00		1.00	0.96	
8												1.00	

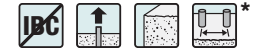

See notes below.

Spacing Tension (f_s)

s_{act} (in.)	Dia.	¾			7/8		1		1¼	
	E	3%	5	6¼	3⅞	7⅞	4½	9	5⅞	9½
	s_{cr}	4¾	7	9½	5⅞	11	6¼	12⅝	7⅞	13¼
	s_{min}	1¾	2½	3%	2	4	2¼	4½	2⅞	4¾
	f_{smin}	0.43	0.43	0.70	0.43	0.70	0.43	0.70	0.43	0.70
2		0.48			0.43					
3		0.67	0.49		0.60		0.54		0.46	
4		0.86	0.62	0.73	0.77	0.70	0.68		0.57	
5		1.00	0.75	0.78	0.94	0.74	0.82	0.72	0.68	0.71
6			0.87	0.83	1.00	0.79	0.96	0.76	0.79	0.74
7			1.00	0.88		0.83	1.00	0.79	0.90	0.78
8				0.93		0.87		0.83	1.00	0.81
9				0.98		0.91		0.87		0.85
10				1.00		0.96		0.90		0.89
11						1.00		0.94		0.92
12								0.98		0.96
13								1.00		0.99
14										1.00



1. E = Embedment depth (inches).
2. s_{act} = actual spacing distance at which anchors are installed (inches).
3. s_{cr} = critical spacing distance for 100% load (inches).
4. s_{min} = minimum spacing distance for reduced load (inches).
5. f_s = adjustment factor for allowable load at actual spacing distance.
6. f_{scr} = adjustment factor for allowable load at critical spacing distance. f_{scr} is always = 1.00.
7. f_{smin} = adjustment factor for allowable load at minimum spacing distance.
8. $f_s = f_{smin} + [(1 - f_{smin}) (s_{act} - s_{min}) / (s_{cr} - s_{min})]$.

* See page 12 for an explanation of the load table icons.

Wedge-All® Design Information — Concrete

Allowable Load-Adjustment Factors for Carbon-Steel and Stainless-Steel Wedge-All® Anchors in Normal-Weight Concrete: Spacing, Shear Loads

How to use these charts:

1. The following tables are for reduced spacing.
2. Locate the anchor size to be used for a shear load application.
3. Locate the anchor embedment (E) used for a shear load application.
4. Locate the spacing (s_{act}) at which the anchor is to be installed.
5. The load adjustment factor (f_s) is the intersection of the row and column.
6. Multiply the allowable load by the applicable load adjustment factor.
7. Reduction factors for multiple spacings are multiplied together.

Spacing Shear (f_s)

s_{act} (in.)	Dia.	¼				⅜		½			⅝		
	E	1⅞	2¼	1¾	2⅝	3⅞	2¼	3⅞	4½	2¾	4½	5½	
	s_{cr}	1⅞	3⅞	2⅞	3⅝	4¾	3⅞	4¾	6¼	3⅞	6¼	7¾	
	s_{min}	⅝	1⅞	⅞	1⅞	1¾	1⅞	1¾	2¼	1⅞	2¼	2¾	
	f_{smin}	0.79	0.79	0.79	0.79	0.79	0.79	0.79	0.79	0.79	0.79	0.79	
¾		0.82											
1		0.87		0.81									
1¼		0.92	0.80	0.84			0.80						
1½		0.97	0.83	0.88	0.80		0.83			0.80			
1¾		1.00	0.86	0.91	0.83	0.79	0.86	0.79		0.82			
2			0.88	0.95	0.85	0.81	0.88	0.81		0.84			
2¼			0.91	0.98	0.87	0.83	0.91	0.83	0.79	0.86	0.79		
2½			0.93	1.00	0.90	0.84	0.93	0.84	0.80	0.88	0.80		
2¾			0.96		0.92	0.86	0.96	0.86	0.82	0.91	0.82	0.79	
3			0.99		0.94	0.88	0.99	0.88	0.83	0.93	0.83	0.80	
3½			1.00		0.99	0.91	1.00	0.91	0.86	0.97	0.86	0.82	
4					1.00	0.95		0.95	0.88	1.00	0.88	0.84	
4½						0.98		0.98	0.91		0.91	0.86	
5						1.00		1.00	0.93		0.93	0.88	
6									0.99		0.99	0.93	
7									1.00		1.00	0.97	
8												1.00	

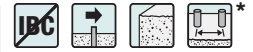

See notes below.

Spacing Shear (f_s)

s_{act} (in.)	Dia.	¾			⅞		1		1¼	
	E	3⅞	5	6¼	3⅞	7⅞	4½	9	5⅞	9½
	s_{cr}	4¾	7	9½	5⅞	11	6¼	12⅝	7⅞	13¼
	s_{min}	1¾	2½	3⅞	2	4	2¼	4½	2⅞	4¾
	f_{smin}	0.79	0.79	0.79	0.79	0.79	0.79	0.79	0.79	0.79
2		0.81			0.79					
3		0.88	0.81		0.85		0.83		0.80	
4		0.95	0.86	0.81	0.91	0.79	0.88		0.84	
5		1.00	0.91	0.85	0.98	0.82	0.93	0.80	0.88	0.80
6			0.95	0.88	1.00	0.85	0.99	0.83	0.92	0.82
7			1.00	0.91		0.88	1.00	0.85	0.96	0.85
8				0.95		0.91		0.88	1.00	0.87
9				0.98		0.94		0.91		0.90
10				1.00		0.97		0.93		0.92
11						1.00		0.96		0.94
12								0.98		0.97
13								1.00		0.99
14										1.00



1. E = Embedment depth (inches).
2. s_{act} = actual spacing distance at which anchors are installed (inches).
3. s_{cr} = critical spacing distance for 100% load (inches).
4. s_{min} = minimum spacing distance for reduced load (inches).
5. f_s = adjustment factor for allowable load at actual spacing distance.
6. f_{scr} = adjustment factor for allowable load at critical spacing distance. f_{scr} is always = 1.00.
7. f_{smin} = adjustment factor for allowable load at minimum spacing distance.
8. $f_s = f_{smin} + [(1 - f_{smin}) (s_{act} - s_{min}) / (s_{cr} - s_{min})]$.

* See page 12 for an explanation of the load table icons.

Wedge-All® Design Information — Concrete

Allowable Load-Adjustment Factors for Carbon-Steel Wedge-All® Anchors in Sand-Lightweight Concrete: Edge Distance, Tension and Shear Loads

How to use these charts:

1. The following tables are for reduced edge distance.
2. Locate the anchor size to be used for either a tension and/or shear load application.
3. Locate the edge distance (c_{act}) at which the anchor is to be installed.
4. The load adjustment factor (f_c) is the intersection of the row and column.
5. Multiply the allowable load by the applicable load adjustment factor.
6. Reduction factors for multiple edges are multiplied together.

Edge Distance Tension (f_c)

Edge Dist. c_{act} (in.)	Size	1/4	1/2	5/8	3/4
	c_{cr}	3 3/8	6 3/4	8 3/8	10
	c_{min}	1 3/8	2 3/4	3 3/8	4
	f_{cmin}	0.70	0.70	0.70	0.70
1 3/8		0.70			
1 1/2		0.72			
2		0.79			
2 1/2		0.87			
2 3/4		0.91	0.70		
3		0.94	0.72		
3 3/8		1.00	0.75	0.70	
3 1/2			0.76	0.71	
4			0.79	0.74	0.70
4 1/2			0.83	0.77	0.73
5			0.87	0.80	0.75
5 1/2			0.91	0.83	0.78
6			0.94	0.86	0.80
6 1/2			0.98	0.89	0.83
6 3/4			1.00	0.90	0.84
7				0.92	0.85
7 1/2				0.95	0.88
8				0.98	0.90
8 3/8				1.00	0.92
8 1/2					0.93
9					0.95
9 1/2					0.98
10					1.00

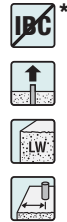

See Notes Below

Edge Distance Shear (f_c) (Shear Applied Perpendicular to Edge)

Edge Dist. c_{act} (in.)	Size	1/4	1/2	5/8	3/4
	c_{cr}	3 3/8	6 3/4	8 3/8	10
	c_{min}	1 3/8	2 3/4	3 3/8	4
	f_{cmin}	0.30	0.30	0.30	0.30
1 3/8		0.30			
1 1/2		0.34			
2		0.52			
2 1/2		0.69			
2 3/4		0.78	0.30		
3		0.87	0.34		
3 3/8		1.00	0.41	0.30	
3 1/2			0.43	0.32	
4			0.52	0.39	0.30
4 1/2			0.61	0.46	0.36
5			0.69	0.53	0.42
5 1/2			0.78	0.60	0.48
6			0.87	0.67	0.53
6 1/2			0.96	0.74	0.59
6 3/4			1.00	0.77	0.62
7				0.81	0.65
7 1/2				0.88	0.71
8				0.95	0.77
8 3/8				1.00	0.81
8 1/2					0.83
9					0.88
9 1/2					0.94
10					1.00

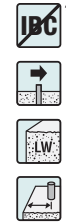

See Notes Below

Load Adjustment Factors for Carbon-Steel Wedge-All® Anchors in Face-of-Wall Installation in 8" Grout-Filled CMU: Edge Distance, Tension and Shear Loads

Edge Distance Tension (f_c)

Edge Dist. c_{act} (in.)	Size	3/8	1/2	5/8	3/4
	c_{cr}	10 1/2	14	17 1/2	21
	c_{min}	4	4	4	4
	f_{cmin}	1.00	1.00	0.80	0.80
4		1.00	1.00	0.80	0.80
6		1.00	1.00	0.83	0.82
8		1.00	1.00	0.86	0.85
10 1/2		1.00	1.00	0.90	0.88
12			1.00	0.92	0.89
14			1.00	0.95	0.92
16				0.98	0.94
17 1/2				1.00	0.96
21					1.00

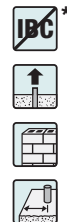

Edge Distance Shear (f_c)

Edge Dist. c_{act} (in.)	Size	3/8	1/2	5/8	3/4
	c_{cr}	10 1/2	14	17 1/2	21
	c_{min}	4	4	4	4
	f_{cmin}	0.79	0.52	0.32	0.32
4		0.79	0.52	0.32	0.32
6		0.85	0.62	0.42	0.40
8		0.92	0.71	0.52	0.48
10 1/2		1.00	0.83	0.65	0.58
12			0.90	0.72	0.64
14			1.00	0.82	0.72
16				0.92	0.80
17 1/2				1.00	0.86
21					1.00

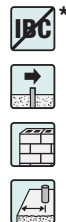

1. c_{act} = actual edge distance at which anchor is installed (inches).
2. c_{cr} = critical edge distance for 100% load (inches).
3. c_{min} = minimum edge distance for reduced load (inches).
4. f_c = adjustment factor for allowable load at actual edge distance.
5. $f_{c_{cr}}$ = adjustment factor for allowable load at critical edge distance. $f_{c_{cr}}$ is always = 1.00.
6. $f_{c_{min}}$ = adjustment factor for allowable load at minimum edge distance.
7. $f_c = f_{c_{min}} + [(1 - f_{c_{min}})(c_{act} - c_{min}) / (c_{cr} - c_{min})]$

Load-Adjustment Factors for Reduced Spacing:

Critical spacing is listed in the load tables. No adjustment in load is required when the anchors are spaced at critical spacing. No additional testing has been performed to determine the adjustment factors for spacing dimensions less than those listed in the load tables.

* See page 12 for an explanation of the load table icons.

Tie-Wire Wedge Anchor

The Tie-Wire anchor is a wedge-style expansion anchor for use in normal-weight concrete or in concrete over metal deck. With a tri-segmented, dual-embossed clip, the Tie-Wire anchor is ideal for the installation of acoustic ceiling grid and is easily set with the claw of a hammer.

Features

- ¼" eyelet for easy threading of wire
- Sets with claw of hammer
- Tri-segmented clip – each segment adjusts independently to hole irregularities
- Dual embossments on each clip segment enable the clip to undercut into the concrete, increasing follow-up expansion
- Wedge-style expansion anchor for use in normal weight concrete or concrete over metal deck

Material: Carbon steel

Coating: Zinc plated

Installation

1. Drill a hole at least 1 ½" deep using a ¼" diameter carbide tipped bit.
2. Drive the anchor into the hole until the bottom of the head is flush with the base material.
3. Set the anchor by prying/pulling the head with the claw end of the hammer.

Size (in.)	Model No.	Drill Bit Dia. (in.)	Eyelet Hole Size (in.)	Quantity	
				Box	Carton
¼" x 1 ½"	TW25112	¼	¼	100	500



Installation Sequence

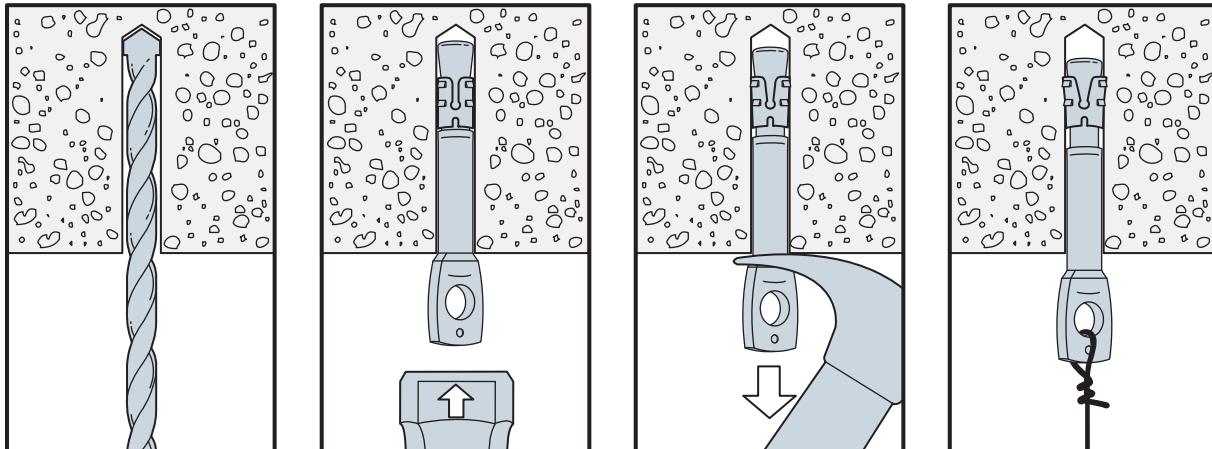

Tie-Wire Design Information — Concrete

Allowable Tension and Shear Loads for Tie-Wire Anchor in Normal-Weight Concrete

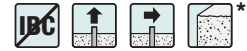

Size in. (mm)	Drill Bit Dia. in.	Embed Depth in. (mm)	Critical End Dist. in. (mm)	Critical Spacing in. (mm)	Tension Load		Shear Load	
					$f'_c \geq 2,500$ psi (17.2 MPa)		$f'_c \geq 2,500$ psi (17.2 MPa)	
					Ultimate lb. (kN)	Allowable lb. (kN)	Ultimate lb. (kN)	Allowable lb. (kN)
1/4 (6.4)	1/4	1 1/2 (38)	2 1/2 (64)	5 (127)	1,155 (5.1)	290 (1.3)	380 (1.7)	95 (0.4)

1. The allowable loads listed are based on a safety factor of 4.0.
2. The minimum concrete thickness is 1 1/2 times the embedment depth.

Allowable Tension and Shear Loads for Tie-Wire Anchor in the Soffit of Normal-Weight Concrete or Sand-Lightweight Concrete over Metal Deck

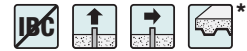

Size in. (mm)	Drill Bit Dia. in.	Embed Depth in. (mm)	Critical End Dist. ⁵ in. (mm)	Critical Spacing in. (mm)	Tension Load		Shear Load	
					$f'_c \geq 3,000$ psi (20.7 MPa)		$f'_c \geq 3,000$ psi (20.7 MPa)	
					Ultimate lb. (kN)	Allowable lb. (kN)	Ultimate lb. (kN)	Allowable lb. (kN)
1/4 (6.4)	1/4	1 1/2 (38)	2 1/2 (64)	5 (127)	1,155 (5.1)	290 (1.3)	460 (2.0)	115 (0.5)

1. The allowable loads listed are based on a safety factor of 4.0.
2. The minimum concrete thickness is 1 1/2 times the embedment depth.
3. Metal deck must be minimum 20-gauge thick with minimum yield strength of 33 ksi.
4. Anchors installed in the bottom flute of the steel deck must have a minimum edge distance of 1 1/2" away from inclined edge of the bottom flute. See the figure below.
5. Critical end distance is defined as the distance from the end of the slab in the direction of the flute.

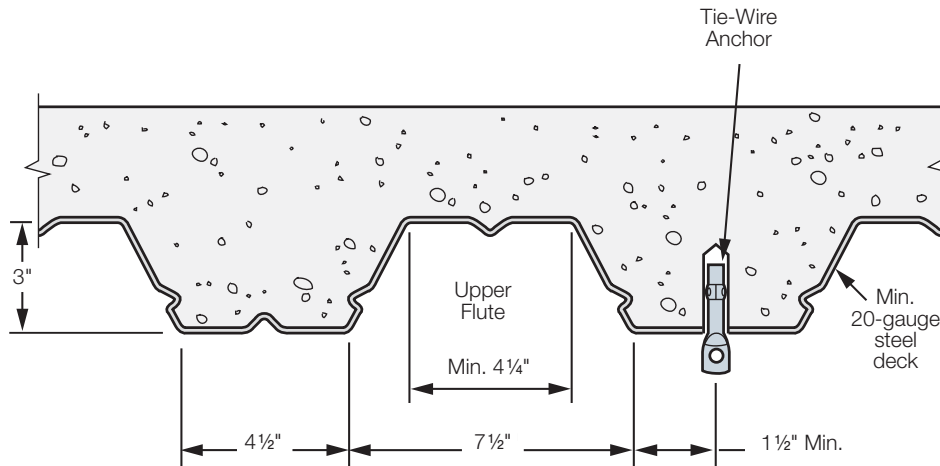

Installation in the Soffit of Concrete over Metal Deck

* See page 12 for an explanation of the load table icons.

Easy-Set Pin-Drive Expansion Anchor

The Easy-Set is a pin-drive expansion anchor for medium- and heavy-duty fastening applications into concrete and grout-filled block. Integrated nut and washer help keep track of parts.

Material: Carbon steel

Coating: Yellow zinc dichromate plated

Installation

Caution: Oversized holes in the base material will make it difficult to set the anchor and will reduce the anchor's load capacity.

1. Drill a hole in the base material using a carbide drill bit the same diameter as the nominal diameter of the anchor to be installed. Drill the hole to the specified embedment depth plus ¼" to allow for pin extension and blow it clean using compressed air. (Overhead installations need not be blown clean.) Alternatively, drill the hole deep enough to accommodate embedment depth and the dust from drilling.
2. Adjust the nut for required embedment. Place the anchor through the fixture and into the hole.
3. Hammer the center pin until the bottom of the head is flush with top of anchor.

Installation Sequence

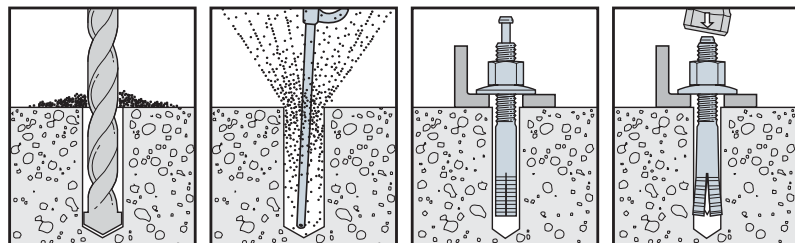

**Easy-Set
(EZAC)**

Mechanical Anchors

EZAC Product Data

Size (in.)	Model No.	Thread Length (in.)	Quantity	
			Box	Carton
¾ x 2¾	EZAC37238	1	50	250
¾ x 3½	EZAC37312	1½	50	250
¾ x 4¾	EZAC37434	1½	50	200
½ x 2¾	EZAC50234	1	25	125
½ x 3½	EZAC50312	1½	25	125
½ x 4¾	EZAC50434	1½	25	100
½ x 6	EZAC50600	2	25	100
⅝ x 4	EZAC62400	1½	15	60
⅝ x 4¾	EZAC62434	1½	15	60
⅝ x 6	EZAC62600	2	15	60

Easy-Set Anchor Installation Data

Easy-Set Dia. (in.)	¾	½	⅝
Drill Bit Size (in.)	¾	½	⅝
Min. Fixture Hole Size (in.)	7/16	9/16	11/16
Wrench Size (in.)	9/16	¾	15/16

EZAC Allowable Tension and Shear Loads in Normal-Weight Concrete

Size in.	Embed. Depth in. (mm)	Drill Bit Dia. in.	Critical Edge Dist. in. (mm)	Critical Spacing Dist. in. (mm)	Tension Load	Shear Load
					$f'_c \geq 2,000$ psi (13.8 MPa) Concrete	
					Allowable lb. (kN)	
¾	1¾ (44)	¾	2¾ (70)	5¼ (133)	630 (2.8)	645 (2.9)
½	2½ (64)	½	3¾ (86)	6¾ (171)	1,005 (4.5)	1,230 (5.5)
⅝	3 (76)	⅝	4¾ (108)	9 (229)	1,515 (6.7)	1,325 (5.9)



1. The allowable loads listed are based on a safety factor of 4.0.
2. 100% of the allowable load is permitted at critical spacing and critical edge distance. Allowable loads at lesser spacings and edge distance have not been determined.
3. The minimum concrete thickness is 1 ½ times the embedment depth.
4. Tension and shear loads for the EZAC anchor may be combined using the straight-line interaction equation ($n = 1$).

* See page 12 for an explanation of the load table icons.

Sleeve-All® Sleeve Anchor

Sleeve-All® expanding anchors are pre-assembled, expanding sleeve anchors for use in all types of solid base materials. This anchor is available in acorn, hex, rod coupler, flat or round head style for a wide range of applications.

Codes: Factory Mutual 3017082, 3026805 and 3029959 (3/8" – 1/2" diameter); Underwriters Laboratories File Ex3605 (3/8" – 3/4" diameter); Multiple DOT listings; meets the requirements of Federal Specification A-A-1922A

Material: Carbon steel or stainless steel

Coating: Carbon steel anchors are zinc plated

Installation

1. Drill a hole in the base material using a carbide drill bit the same diameter as the nominal diameter of the anchor to be installed.
2. Drill the hole to the specified embedment depth, and blow it clean using compressed air. (Overhead installations need not be blown clean.) Alternatively, drill the hole deep enough to accommodate embedment depth and the dust from drilling.
3. Place the anchor in the fixture, and drive it into the hole until the washer and nut are tight against the fixture.
4. Tighten to required installation torque.

Caution: Oversized holes will make it difficult to set the anchor and will reduce the anchor's load capacity.

Installation Sequence

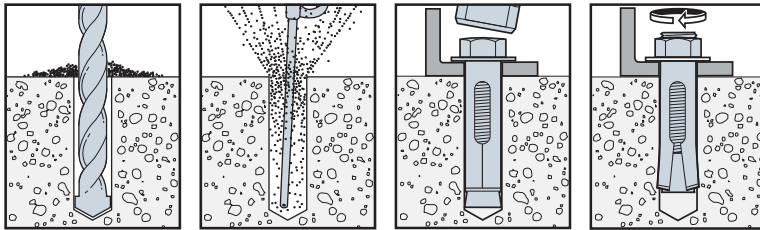

Material Specifications

Anchor Component	Zinc-Plated Carbon Steel	304 Stainless Steel
Anchor Body	Material meets minimum 50,000 psi tensile	Type 304
Sleeve	SAE J403, Grade 1008 Cold-Rolled Steel	Type 304
Nut	Commercial Grade, meets requirements of ASTM A563 Grade A	Type 304
Washer	SAE J403, Grade 1008/1010 Cold-Rolled Steel	Type 304

Sleeve-All® Anchor Installation Data

Sleeve-All Dia. (in.)	1/4	5/16	3/8	1/2	5/8	3/4
Drill Bit Size (in.)	1/4	5/16	3/8	1/2	5/8	3/4
Wrench Size ¹ (in.)	3/8	7/16	1/2	9/16	3/4	15/16
Wrench Size for Coupler Nut (in.)			1/2	5/8	3/4	—

1. Applies to acorn- and hex-head configurations only.



Hex



Acorn



Rod Coupler



Round



Flat Head (Phillips Drive)



Sleeve-All® Sleeve Anchor

Sleeve-All® Anchor Product Data – Zinc-Plated Carbon Steel

Size (in.)	Model No.	Head Style	Bolt Diameter – Threads per inch	Max. Fixture Thickness (in.)	Quantity	
					Box	Carton
¼ x 1 ¾	SL25138A	Acorn Head	¾–24	¼	100	500
¼ x 2 ¼	SL25214A			1 ½	100	500
⅝ x 1 ½*	SL31112H	Hex Head	¼–20	⅜	100	500
⅝ x 2 ½	SL31212H			1 ⅛	50	250
⅜ x 1 ⅞	SL37178H		⅝–18	⅜	50	250
⅜ x 3	SL37300H			1 ½	50	200
⅜ x 4	SL37400H			2 ¼	50	200
½ x 2 ¼*	SL50214H			½	50	200
½ x 3	SL50300H		⅜–16	¾	25	100
½ x 4	SL50400H			1 ¼	25	100
½ x 6	SL50600H			3 ⅜	20	80
⅝ x 2 ¼*	SL62214H		½–13	½	25	100
⅝ x 3	SL62300H			¾	20	80
⅝ x 4 ¼	SL62414H			1 ½	10	40
⅝ x 6	SL62600H			3 ¼	10	40
¾ x 2 ½*	SL75212H		⅝–11	½	10	40
¾ x 4 ¼	SL75414H			7 ⁄8	10	40
¾ x 6 ¼	SL75614H			2 7 ⁄8	5	20
¼ x 2	SL25200PF	Phillips Flat Head	¾–24	7 ⁄8	100	500
¼ x 3	SL25300PF			1 7 ⁄8	50	250
⅝ x 2 ½	SL31212PF		¼–20	1 ⅛	50	250
⅝ x 3 ½	SL31312PF			2 ⅛	50	250
⅜ x 2 ¾	SL37234PF		⅝–18	1 ¼	50	200
⅜ x 4	SL37400PF			2 ½	50	200
⅜ x 5	SL37500PF			3 ½	50	200
⅜ x 6	SL37600PF			4 ½	50	200
¼ x 2 ¾	SL25234	Round Head	¾–24	7 ⁄8	50	250

*These models do not meet minimum embedment requirements for rated load values.

Mechanical Anchors

Sleeve-All® Anchor Product Data – Stainless Steel

Size (in.)	Model No.	Head Style	Bolt Diameter – Threads per inch	Max. Fixture Thickness (in.)	Quantity	
					Box	Carton
⅜ x 1 ⅞	SL37178HSS	Hex Head	⅝–18	⅜	50	250
⅜ x 3	SL37300HSS			1 ½	50	200
½ x 3	SL50300HSS		⅜–16	¾	25	100
½ x 4	SL50400HSS			1 ¼	25	100

Sleeve-All® Anchor (with rod coupler) Product Data – Zinc-Plated Carbon Steel

Size (in.)	Model No.	Accepts Rod Dia. (in.)	Wrench Size	Quantity	
				Box	Carton
⅜ x 1 ⅞	SL37178C	⅜	½	50	200
½ x 2 ¼	SL50214C	½	⅝	25	100
⅝ x 2 ¼	SL62214C	⅝	¾	20	80

Length Identification Head Marks on Sleeve-All Anchors (corresponds to length of anchor – inches)

Mark	A	B	C	D	E	F	G	H	I	J	K	L	M	N	O	P	Q	R	S	T	U	V	W	X	Y	Z
From	1 ½	2	2 ½	3	3 ½	4	4 ½	5	5 ½	6	6 ½	7	7 ½	8	8 ½	9	9 ½	10	11	12	13	14	15	16	17	18
Up To But Not Including	2	2 ½	3	3 ½	4	4 ½	5	5 ½	6	6 ½	7	7 ½	8	8 ½	9	9 ½	10	11	12	13	14	15	16	17	18	19

Sleeve-All® Design Information — Concrete and Masonry

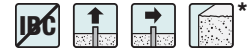

Allowable Tension and Shear Loads for Sleeve-All® in Normal-Weight Concrete

Size in. (mm)	Embed. Depth in. (mm)	Critical Edge Dist. in. (mm)	Critical Spacing Dist. in. (mm)	Tension Load						Shear Load			Install. Torque ft.-lb. (N-m)
				$f'_c \geq 2,000$ psi (13.8 MPa) Concrete			$f'_c \geq 4,000$ psi (27.6 MPa) Concrete			$f'_c \geq 2,000$ psi (13.8 MPa) Concrete			
				Ultimate lb. (kN)	Std. Dev. lb. (kN)	Allow. lb. (kN)	Ultimate lb. (kN)	Std. Dev. lb. (kN)	Allow. lb. (kN)	Ultimate lb. (kN)	Std. Dev. lb. (kN)	Allow. lb. (kN)	
¼ (6.4)	1½ (29)	2½ (64)	4½ (114)	880 (3.9)	94 (0.4)	220 (1.0)	1,320 (5.9)	189 (0.8)	330 (1.5)	1,440 (6.4)	90 (0.4)	360 (1.6)	5 (7)
⅝ (7.9)	1⅞ (37)	3⅞ (79)	5¾ (146)	1,120 (5.0)	113 (0.5)	280 (1.2)	1,320 (5.9)	350 (1.6)	330 (1.5)	2,160 (9.6)	113 (0.5)	540 (2.4)	8 (11)
¾ (9.5)	1½ (38)	3¾ (95)	6 (152)	1,600 (7.1)	294 (1.3)	400 (1.8)	2,680 (11.9)	450 (2.0)	670 (3.0)	3,080 (13.7)	223 (1.0)	770 (3.4)	15 (20)
½ (12.7)	2¼ (57)	5 (127)	9 (229)	3,160 (14.1)	254 (1.1)	790 (3.5)	4,760 (21.2)	485 (2.2)	1,190 (5.3)	5,000 (22.2)	473 (2.1)	1,250 (5.6)	25 (34)
⅝ (15.9)	2¾ (70)	6¼ (159)	11 (279)	4,200 (18.7)	681 (3.0)	1,050 (4.7)	6,160 (27.4)	1,772 (7.9)	1,540 (6.9)	8,520 (37.9)	713 (3.2)	2,130 (9.5)	50 (68)
¾ (19.1)	3¾ (86)	7½ (191)	13½ (343)	6,400 (28.5)	665 (3.0)	1,600 (7.1)	9,520 (42.3)	674 (3.0)	2,380 (10.6)	10,040 (44.7)	955 (4.2)	2,510 (11.2)	90 (122)

1. The tabulated allowable loads are based on a safety factor of 4.0.
2. Allowable loads may not be increased for short-term loading due to wind or seismic forces.
3. Refer to allowable load-adjustment factors for spacing and edge distance on page 183.
4. Drill bit diameter used in base material corresponds to nominal anchor diameter.
5. Allowable tension loads may be linearly interpolated between concrete strengths listed.
6. The minimum concrete thickness is 1 ½ times the embedment depth.

Allowable Tension and Shear Loads for ⅝" Sleeve-All® in Grout-Filled CMU (Anchor Installed in Horizontal Mortar Joint or Face Shell)

Size in. (mm)	Embed. Depth in. (mm)	Min. Edge Dist. in. (mm)	Min. End Dist. in. (mm)	Min. Spacing in. (mm)	Tension Load		Shear Load		Install. Torque ft.-lb. (N-m)
					Ultimate lb. (kN)	Allow. lb. (kN)	Ultimate lb. (kN)	Allow. lb. (kN)	
⅝ (9.5)	1½ (38)	16 (406)	16 (406)	24 (610)	2,000 (8.9)	400 (1.8)	2,300 (10.2)	460 (2.0)	15 (20)

See notes beneath following table.

Allowable Tension and Shear Loads for Sleeve-All® in Grout-Filled CMU

Size in. (mm)	Embed. Depth in. (mm)	Min. Edge Dist. in. (mm)	Min. End Dist. in. (mm)	Min. Spacing in. (mm)	Tension Load		Shear Load		Install. Torque ft.-lb. (N-m)
					Ultimate lb. (kN)	Allow. lb. (kN)	Ultimate lb. (kN)	Allow. lb. (kN)	
Anchor Installed in a Single Face Shell									
⅝ (9.5)	1½ (38)	12 (305)	12 (305)	24 (610)	1,746 (7.8)	350 (1.6)	2,871 (12.8)	575 (2.6)	15 (20)
½ (12.7)	2¼ (57)	12 (305)	12 (305)	24 (610)	3,384 (15.1)	675 (3.0)	5,670 (25.2)	1,135 (5.0)	25 (34)
⅝ (15.9)	2¾ (70)	12 (305)	12 (305)	24 (610)	3,970 (17.7)	795 (3.5)	8,171 (36.3)	1,635 (7.3)	50 (68)
¾ (19.1)	3¾ (86)	12 (305)	12 (305)	24 (610)	6,395 (28.4)	1,280 (5.7)	12,386 (55.1)	2,475 (11.0)	90 (122)
Anchor Installed in Mortar "T" Joint									
⅝ (9.5)	1½ (38)	8 (203)	8 (203)	24 (610)	1,927 (8.6)	385 (1.7)	3,436 (15.3)	685 (3.0)	15 (20)
½ (12.7)	2¼ (57)	8 (203)	8 (203)	24 (610)	3,849 (17.1)	770 (3.4)	5,856 (26.0)	1,170 (5.2)	25 (34)
⅝ (15.9)	2¾ (70)	8 (203)	8 (203)	24 (610)	4,625 (20.6)	925 (4.1)	7,040 (31.3)	1,410 (6.3)	50 (68)
¾ (19.1)	3¾ (86)	8 (203)	8 (203)	24 (610)	5,483 (24.4)	1,095 (4.9)	7,869 (35.0)	1,575 (7.0)	90 (122)

1. The tabulated allowable loads are based on a safety factor of 5.0.
2. Listed loads may be applied to installations through a face shell with the following placement guidelines:
 - a. Minimum 3" from vertical mortar joint.
 - b. Minimum 1" from vertical cell centerline.
3. Values for 6- and 8-inch-wide concrete masonry units (CMU) with a minimum specified compressive strength of masonry, f'_m , at 28 days is 1,500 psi.
4. Embedment depth is measured from the outside face of the concrete masonry unit.
5. Drill bit diameter used in base material corresponds to nominal anchor diameter.

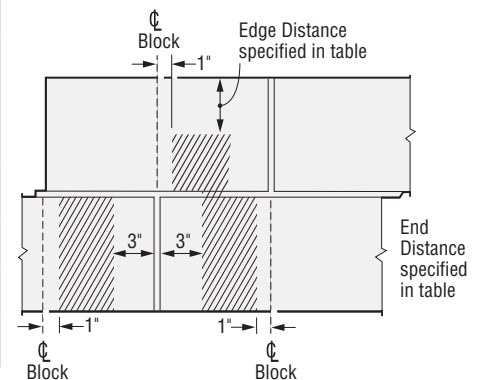

Face Shell Installation
Allowable Anchor Placement in grout-filled CMU shown by shaded areas.

* See page 12 for an explanation of the load table icons.

Sleeve-All® Design Information — Concrete

Allowable Load-Adjustment Factors for Sleeve-All® Anchors in Normal-Weight Concrete:
Edge Distance and Spacing, Tension and Shear Loads

How to use these charts:

1. The following tables are for reduced edge distance and spacing.
2. Locate the anchor size to be used for either a tension and/or shear load application.
3. Locate the edge distance (c_{act}) or spacing (s_{act}) at which the anchor is to be installed.
4. The load adjustment factor (f_c or f_s) is the intersection of the row and column.
5. Multiply the allowable load by the applicable load adjustment factor.
6. Reduction factors for multiple edges or spacing are multiplied together.

Edge Distance Tension (f_c)

Edge Dist. Cact (in.)	Size	1/4	5/16	3/8	1/2	5/8	3/4
	c_{cr}	2 1/2	3 1/8	3 3/4	5	6 1/4	7 1/2
c_{min}	1 1/4	1 9/16	1 7/8	2 1/2	3 1/8	3 3/4	
f_{cmin}	0.60	0.60	0.60	0.60	0.60	0.60	0.60
1 1/4		0.60					
1 1/2		0.68					
1 9/16		0.70	0.60				
1 7/8		0.80	0.68	0.60			
2		0.84	0.71	0.63			
2 1/2		1.00	0.84	0.73	0.60		
3			0.97	0.84	0.68		
3 1/8			1.00	0.87	0.70	0.60	
3 1/2				0.95	0.76	0.65	
3 3/4				1.00	0.80	0.68	0.60
4					0.84	0.71	0.63
4 1/2					0.92	0.78	0.68
5					1.00	0.84	0.73
5 1/2						0.90	0.79
6						0.97	0.84
6 1/4						1.00	0.87
6 1/2							0.89
7							0.95
7 1/2							1.00

See notes below.

Edge Distance Shear (f_c)

Edge Dist. Cact (in.)	Size	1/4	5/16	3/8	1/2	5/8	3/4
	c_{cr}	2 1/2	3 1/8	3 3/4	5	6 1/4	7 1/2
c_{min}	1 1/4	1 9/16	1 7/8	2 1/2	3 1/8	3 3/4	
f_{cmin}	0.30	0.30	0.30	0.30	0.30	0.30	0.30
1 1/4		0.30					
1 1/2		0.44					
1 9/16		0.48	0.30				
1 7/8		0.65	0.44	0.30			
2		0.72	0.50	0.35			
2 1/2		1.00	0.72	0.53	0.30		
3			0.94	0.72	0.44		
3 1/8			1.00	0.77	0.48	0.30	
3 1/2				0.91	0.58	0.38	
3 3/4				1.00	0.65	0.44	0.30
4					0.72	0.50	0.35
4 1/2					0.86	0.61	0.44
5					1.00	0.72	0.53
5 1/2						0.83	0.63
6						0.94	0.72
6 1/4						1.00	0.77
6 1/2							0.81
7							0.91
7 1/2							1.00

1. c_{act} = actual edge distance at which anchor is installed (inches).
2. c_{cr} = critical edge distance for 100% load (inches).
3. c_{min} = minimum edge distance for reduced load (inches).
4. f_c = adjustment factor for allowable load at actual edge distance.
5. f_{ccr} = adjustment factor for allowable load at critical edge distance.
 f_{ccr} is always = 1.00.
6. f_{cmin} = adjustment factor for allowable load at minimum edge distance.
7. $f_c = f_{cmin} + [(1 - f_{cmin}) (c_{act} - c_{min}) / (c_{cr} - c_{min})]$.

* See page 12 for an explanation of the load table icons.

Spacing Tension and Shear (f_s)

Sact (in.)	Size	1/4	5/16	3/8	1/2	5/8	3/4
	E	1 1/8	1 7/16	1 1/2	2 1/4	2 3/4	3 3/8
s_{cr}	4 1/2	5 3/4	6	9	11	13 1/2	
s_{min}	2 1/4	2 7/8	3	4 1/2	5 1/2	6 3/4	
f_{smin}	0.50	0.50	0.50	0.50	0.50	0.50	0.50
2 1/4		0.50					
2 1/2		0.56					
2 7/8		0.64	0.50				
3		0.67	0.52	0.50			
3 1/2		0.78	0.61	0.58			
4		0.89	0.70	0.67			
4 1/2		1.00	0.78	0.75	0.50		
5			0.87	0.83	0.56		
5 1/2			0.96	0.92	0.61	0.50	
5 3/4			1.00	0.96	0.64	0.52	
6				1.00	0.67	0.55	
6 1/2					0.72	0.59	
6 3/4					0.75	0.61	0.50
7					0.78	0.64	0.52
8					0.89	0.73	0.59
9					1.00	0.82	0.67
10						0.91	0.74
11						1.00	0.81
12							0.89
13							0.96
13 1/2							1.00

1. E = Embedment depth (inches).
2. s_{act} = actual spacing distance at which anchors are installed (inches).
3. s_{cr} = critical spacing distance for 100% load (inches).
4. s_{min} = minimum spacing distance for reduced load (inches).
5. f_s = adjustment factor for allowable load at actual spacing distance.
6. f_{scr} = adjustment factor for allowable load at critical spacing distance.
 f_{scr} is always = 1.00.
7. f_{smin} = adjustment factor for allowable load at minimum spacing distance.
8. $f_s = f_{smin} + [(1 - f_{smin}) (s_{act} - s_{min}) / (s_{cr} - s_{min})]$.

Titen HD® Heavy-Duty Screw Anchor



The original high-strength screw anchor for use in cracked and uncracked concrete, as well as uncracked masonry. The Titen HD® offers low installation torque and outstanding performance. Designed and tested in dry, interior, non-corrosive environments or temporary outdoor applications, the Titen HD® demonstrates industry-leading performance even in seismic conditions.

Features

- Code listed under IBC/IRC in accordance with ICC-ES AC193 for cracked and uncracked concrete per ICC-ES ESR-2713
- Code listed under IBC/IRC in accordance with ICC-ES AC106 for masonry per ICC-ES ESR-1056
- Qualified for static and seismic loading conditions
- Thread design undercuts to efficiently transfer the load to the base material
- Standard fractional sizes
- Specialized heat-treating process creates tip hardness for better cutting without compromising the ductility
- No special drill bit required — designed to install using standard-sized ANSI tolerance drill bits
- Testing shows the Titen HD® installs in concrete with 50% less torque than competitor anchors
- Hex-washer head requires no separate washer and provides a clean installed appearance
- Removable — ideal for temporary anchoring (e.g., formwork, bracing) or applications where fixtures may need to be moved (reuse of the anchor to achieve listed load values is not recommended)

Codes: ICC-ES ESR-2713 (concrete); ICC-ES ESR-1056 (masonry); City of L.A. RR25741 (concrete), RR25560 (masonry); Florida FL-15730.6; FM 3017082, 3035761 and 3043442; Multiple DOT listings

Material: Carbon steel

Coating: Zinc plated or mechanically galvanized

Installation

- Holes in metal fixtures to be mounted should match the diameter specified in the table below. Use a Titen HD® screw anchor one time only — installing the anchor multiple times may result in excessive thread wear and reduce load capacity.
- Do not use impact wrenches to install into hollow CMU.
- Caution:** Oversized holes in base material will reduce or eliminate the mechanical interlock of the threads with the base material and reduce the anchor's load capacity.

1. Drill a hole in the base material using a carbide drill bit the same diameter as the nominal diameter of the anchor to be installed. Drill the hole to the specified embedment depth plus minimum hole depth overall (see table below right) to allow the thread tapping dust to settle, and blow it clean using compressed air. (Overhead installations need not be blown clean.) Alternatively, drill the hole deep enough to accommodate embedment depth and the dust from drilling and tapping.
2. Insert the anchor through the fixture and into the hole.
3. Tighten the anchor into the base material until the hex-washer head contacts the fixture.

Installation Sequence

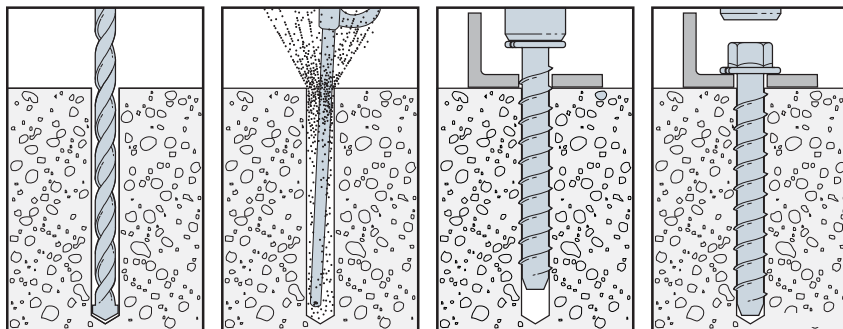

Additional Installation Information

Titen HD® Diameter (in.)	Wrench Size (in.)	Recommended Fixture Hole Size (in.)	Min. Hole Depth Overdrill (in.)
1/4	3/8	3/8 to 7/16	1/8
3/8	9/16	1/2 to 9/16	1/4
1/2	3/4	5/8 to 11/16	1/2
5/8	15/16	3/4 to 13/16	1/2
3/4	1 1/8	7/8 to 15/16	1/2

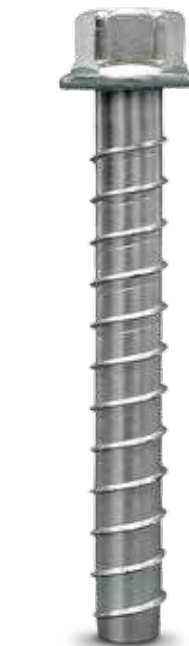

**Titen HD®
Screw Anchor**
U.S. Patents 5,674,035
and 6,623,228



Serrated teeth on the tip of the Titen HD® screw anchor facilitate cutting and reduce installation torque.

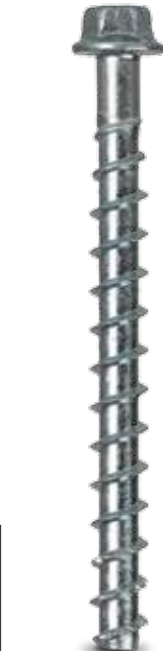

**NEW 1/4" Titen HD®
Screw Anchor**
U.S. Patents 5,674,035
and 6,623,228

Titen HD® Heavy-Duty Screw Anchor

Titen HD® Anchor Product Data — Zinc Plated

Size (in.)	Model No.	Drill Bit Dia. (in.)	Wrench Size (in.)	Quantity	
				Box	Carton
1/4 x 1 7/8	THDB25178H	1/4	3/8	100	500
1/4 x 2 3/4	THDB25234H	1/4	3/8	50	250
1/4 x 3	THDB25300H	1/4	3/8	50	250
1/4 x 3 1/2	THDB25312H	1/4	3/8	50	250
1/4 x 4	THDB25400H	1/4	3/8	50	250
3/8 x 1 3/4	THD37134H*	3/8	9/16	50	250
3/8 x 2 1/2	THD37212H*	3/8	9/16	50	200
3/8 x 3	THD37300H	3/8	9/16	50	200
3/8 x 4	THD37400H	3/8	9/16	50	200
3/8 x 5	THD37500H	3/8	9/16	50	100
3/8 x 6	THD37600H	3/8	9/16	50	100
1/2 x 3	THD50300H	1/2	3/4	25	100
1/2 x 4	THD50400H	1/2	3/4	20	80
1/2 x 5	THD50500H	1/2	3/4	20	80
1/2 x 6	THD50600H	1/2	3/4	20	80
1/2 x 6 1/2	THD50612H	1/2	3/4	20	40
1/2 x 8	THD50800H	1/2	3/4	5	25
1/2 x 12	THD501200H	1/2	3/4	5	25
1/2 x 13	THD501300H	1/2	3/4	5	25
1/2 x 14	THD501400H	1/2	3/4	5	25
1/2 x 15	THD501500H	1/2	3/4	5	25
5/8 x 4	THDB62400H	5/8	15/16	10	40
5/8 x 5	THDB62500H	5/8	15/16	10	40
5/8 x 6	THDB62600H	5/8	15/16	10	40
5/8 x 6 1/2	THDB62612H	5/8	15/16	10	40
5/8 x 8	THDB62800H	5/8	15/16	10	20
3/4 x 4	THD75400H	3/4	1 1/8	10	40
3/4 x 5	THD7500H	3/4	1 1/8	5	20
3/4 x 6	THD75600H	3/4	1 1/8	5	20
3/4 x 7	THD75700H	3/4	1 1/8	5	10
3/4 x 8 1/2	THD75812H	3/4	1 1/8	5	10
3/4 x 10	THD75100H	3/4	1 1/8	5	10

*These models do not meet minimum embedment depth requirements for strength design and require maximum installation torque of 25 ft. - lb. using a torque wrench, driver drill or cordless 1/4" impact driver with a maximum permitted torque rating of 100 ft. - lb.

Titen HD® Anchor Product Data — Mechanically Galvanized

Size (in.)	Model No.	Drill Bit Dia. (in.)	Wrench Size (in.)	Quantity	
				Box	Carton
3/8 x 5	THD37500HMG	3/8	9/16	50	100
3/8 x 6	THD37600HMG			50	100
1/2 x 5	THD50500HMG	1/2	3/4	20	80
1/2 x 6	THD50600HMG			20	80
1/2 x 6 1/2	THD50612HMG			20	40
1/2 x 8	THD50800HMG			20	40
5/8 x 5	THD62500HMG	5/8	15/16	10	40
5/8 x 6	THD62600HMG			10	40
5/8 x 6 1/2	THD62612HMG			10	40
5/8 x 8	THD62800HMG			10	20
5/8 x 5	THDB62500HMG	5/8	15/16	10	40
5/8 x 6	THDB62600HMG			10	40
5/8 x 6 1/2	THDB62612HMG			10	40
5/8 x 8	THDB62800HMG			10	20
3/4 x 8 1/2	THD75812HMG	3/4	1 1/8	5	10
3/4 x 10	THD75100HMG			5	10

Mechanical galvanizing meets ASTM B695, Class 65, Type 1. Intended for some pressure-treated wood sill plate applications. Not for use in other corrosive or outdoor environments. See page 316 or visit www.strongtie.com/info for more corrosion information.

Titen HD® Installation Information and Additional Data¹

Characteristic	Symbol	Units	Nominal Anchor Diameter, d_a (in.)									
			1/4 ⁴		3/8	1/2		5/8 ⁴		3/4		
Installation Information												
Drill Bit Diameter	d_{bit}	in.	1/4		3/8	1/2		5/8		3/4		
Baseplate Clearance Hole Diameter	d_c	in.	3/8		1/2	5/8		3/4		7/8		
Maximum Installation Torque	$T_{inst,max}$	ft.-lbf	24 ²		50 ²	65 ²		100 ²		150 ²		
Maximum Impact Wrench Torque Rating	$T_{impact,max}$	ft.-lbf	125 ³		150 ³	340 ³		340 ³		385 ³		
Minimum Hole Depth	h_{hole}	in.	1 3/4	2 5/8	2 3/4	3 1/2	3 3/4	4 1/2	4 1/2	6	6	6 3/4
Nominal Embedment Depth	h_{nom}	in.	1 5/8	2 1/2	2 1/2	3 1/4	3 1/4	4	4	5 1/2	5 1/2	6 1/4
Critical Edge Distance	c_{ac}	in.	3	6	2 1/16	3 5/8	3 3/16	4 1/2	4 1/2	6 3/8	6 3/8	7 5/16
Minimum Edge Distance	c_{min}	in.	1 1/2		1 3/4							
Minimum Spacing	s_{min}	in.	3									
Minimum Concrete Thickness	h_{min}	in.	3 1/4	3 1/2	4	5	5	6 1/4	6	8 1/2	8 3/4	10
Additional Data												
Anchor Category	Category	—	1									
Yield Strength	f_{ya}	psi	100,000				97,000					
Tensile Strength	f_{uta}	psi	125,000				110,000					
Minimum Tensile & Shear Stress Area	A_{se}	in ²	0.042		0.099	0.183		0.276		0.414		
Axial Stiffness in Service Load Range — Uncracked Concrete	β_{uncr}	lb./in.	202,000				715,000					
Axial Stiffness in Service Load Range — Cracked Concrete	β_{cr}	lb./in.	173,000				345,000					

- The information presented in this table is to be used in conjunction with the design criteria of ACI 318 Appendix D.
- $T_{inst,max}$ is the maximum permitted installation torque for the embedment depth range covered by this table using a torque wrench.
- $T_{impact,max}$ is the maximum permitted torque rating for impact wrenches for the embedment depth range covered by this table.
- Data for 1/4" anchor is only valid for THDB25 series. Data for the 5/8" anchor is valid only for the THDB62 series.

Titen HD® Design Information — Concrete

Titen HD® Tension Strength Design Data¹

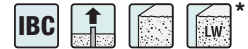

Characteristic	Symbol	Units	Nominal Anchor Diameter, d _a (in.)									
			1/4 ⁹		3/8		1/2		5/8 ⁹		3/4	
Nominal Embedment Depth	<i>h_{nom}</i>	in.	1 5/8	2 1/2	2 1/2	3 1/4	3 1/4	4	4	5 1/2	5 1/2	6 1/4
Steel Strength in Tension												
Tension Resistance of Steel	<i>N_{sa}</i>	lb.	5,195		10,890		20,130		30,360		45,540	
Strength Reduction Factor — Steel Failure	<i>φ_{sa}</i>	—	0.65 ²									
Concrete Breakout Strength in Tension^{6,8}												
Effective Embedment Depth	<i>h_{ef}</i>	in.	1.19	1.94	1.77	2.40	2.35	2.99	2.97	4.24	4.22	4.86
Critical Edge Distance ⁶	<i>c_{ac}</i>	in.	3	6	2 11/16	3 5/8	3 9/16	4 1/2	4 1/2	6 3/8	6 3/8	7 5/16
Effectiveness Factor — Uncracked Concrete	<i>k_{un-cr}</i>	—	30		24							
Effectiveness Factor — Cracked Concrete	<i>k_{cr}</i>	—	17									
Modification Factor	<i>ψ_{cp,N}</i>	—	1.0									
Strength Reduction Factor — Concrete Breakout Failure	<i>φ_{cb}</i>	—	0.65 ⁷									
Pullout Strength in Tension⁸												
Pullout Resistance, Uncracked Concrete (<i>f'_c</i> =2,500 psi)	<i>N_{p,un-cr}</i>	lb.	— ³	— ³	2,700 ⁴	— ³	— ³	— ³	— ³	9,810 ⁴	— ³	— ³
Pullout Resistance, Cracked Concrete (<i>f'_c</i> =2,500 psi)	<i>N_{p,cr}</i>	lb.	— ³	1,905 ⁴	1,235 ⁴	2,700 ⁴	— ³	— ³	3,260 ⁴	5,570 ⁴	6,070 ⁴	7,195 ⁴
Strength Reduction Factor — Concrete Pullout Failure	<i>φ_p</i>	—	0.65 ⁵									
Breakout or Pullout Strength in Tension for Seismic Applications⁸												
Nominal Pullout Strength for Seismic Loads (<i>f'_c</i> =2,500 psi)	<i>N_{p,eq}</i>	lb.	— ³	1,905 ⁴	1,235 ⁴	2,700 ⁴	— ³	— ³	3,260 ⁴	5,570 ⁴	6,070 ⁴	7,195 ⁴
Strength Reduction Factor — Breakout or Pullout Failure	<i>φ_{eq}</i>	—	0.65 ⁵									

- The information presented in this table is to be used in conjunction with the design criteria of ACI 318 Appendix D, except as modified below.
- The value of *φ* applies when the load combinations of ACI 318 Section 9.2 are used. If the load combinations of ACI 318 Appendix C are used, refer to Section D.4.4 to determine the appropriate value of *φ*. Anchors are considered brittle steel elements.
- Pullout strength is not reported since concrete breakout controls.
- Adjust the characteristic pullout resistance for other concrete compressive strengths by multiplying the tabular value by (*f'_{c,specified}* / 2,500)^{0.5}.
- The value of *φ* applies when both the load combinations of ACI 318 Section 9.2 are used and the requirements of Section D.4.3(c) for Condition B are met. If the load combinations of ACI 318 Appendix C are used, refer to Section D.4.4 to determine the appropriate value of *φ*.
- The modification factor *ψ_{cp,N}* = 1.0 for cracked concrete. Otherwise, the modification factor for uncracked concrete without supplementary reinforcement to control splitting is either:

$$(1) \psi_{cp,N} = 1.0 \text{ if } c_{a,min} \geq c_{ac} \text{ or } (2) \psi_{cp,N} = \frac{c_{a,min}}{c_{ac}} \geq \frac{1.5h_{ef}}{c_{ac}} \text{ if } c_{a,min} < c_{ac}$$

The modification factor, *ψ_{cp,N}* is applied to the nominal concrete breakout strength, *N_{cb}* or *N_{cbg}*.

- The value of *φ* applies when both the load combinations of ACI 318 Section 9.2 are used and the requirements of Section D.4.3(c) for Condition B are met. If the load combinations of ACI 318 Section 9.2 are used and the requirements of Section D.4.3(c) for Condition A are met, refer to Section D.4.3 to determine the appropriate value of *φ*. If the load combinations of ACI 318 Appendix C are used, refer to Section D.4.4 to determine the appropriate value of *φ*.
- For sand-lightweight concrete, in lieu of ACI 318 Section D.3.6, modify the value of concrete breakout strength, *N_{p,cr}*, *N_{p,un-cr}* and *N_{eq}* by 0.6. All-lightweight concrete is beyond the scope of this table.
- Data for 1/4" anchor is valid only for THDB25 series. Data for 5/8" anchor is valid only for THDB62 series.

Mechanical Anchors

Titen HD® Shear Strength Design Data¹



Characteristic	Symbol	Units	Nominal Anchor Diameter, d _a (in.)									
			1/4 ⁵		3/8		1/2		5/8 ⁵		3/4	
Nominal Embedment Depth	<i>h_{nom}</i>	in.	1 5/8	2 1/2	2 1/2	3 1/4	3 1/4	4	4	5 1/2	5 1/2	6 1/4
Steel Strength in Shear												
Shear Resistance of Steel	<i>V_{sa}</i>	lb.	2,020		4,460		7,455		10,000		16,840	
Strength Reduction Factor — Steel Failure	<i>φ_{sa}</i>	—	0.60 ²									
Concrete Breakout Strength in Shear⁶												
Outside Diameter	<i>d_a</i>	in.	0.25		0.375		0.500		0.625		0.750	
Load Bearing Length of Anchor in Shear	<i>ℓ_e</i>	in.	1.19	1.94	1.77	2.40	2.35	2.99	2.97	4.24	4.22	4.86
Strength Reduction Factor — Concrete Breakout Failure	<i>φ_{cb}</i>	—	0.70 ⁴									
Concrete Pryout Strength in Shear												
Coefficient for Pryout Strength	<i>k_{cp}</i>	lb.	1.0		2.0							
Strength Reduction Factor — Concrete Pryout Failure	<i>φ_{cp}</i>	—	0.70 ⁴									
Steel Strength in Shear for Seismic Applications												
Shear Resistance for Seismic Loads	<i>V_{eq}</i>	lb.	1,695		2,855		4,790		8,000		9,350	
Strength Reduction Factor — Steel Failure	<i>φ_{eq}</i>	—	0.60 ²									

- The information presented in this table is to be used in conjunction with the design criteria of ACI 318 Appendix D, except as modified below.
- The value of *φ* applies when the load combinations of ACI 318 Section 9.2 are used. If the load combinations of ACI 318 Appendix C are used, refer to Section D.4.4 to determine the appropriate value of *φ*. Anchors are considered brittle steel elements.
- The value of *φ* applies when both the load combinations of ACI 318 Section 9.2 are used and the requirements of Section D.4.3(c) for Condition B are met. If the load combinations of ACI 318 Appendix C are used, refer to Section D.4.4 to determine the appropriate value of *φ*. If the load combinations of ACI 318 Appendix C are used,

refer to Section D.4.4 to determine the appropriate value of *φ*.

- The value of *φ* applies when both the load combinations of ACI 318 Section 9.2 are used and the requirements of Section D.4.3(c) for Condition B are met. If the load combinations of ACI 318 Appendix C are used, refer to Section D.4.4 to determine the appropriate value of *φ*.
- Data for 1/4" anchor is valid only for THDB25 series. Data for 5/8" anchor is valid only for THDB62 series.
- For sand-lightweight concrete, in lieu of ACI 318 Section D.3.6, modify the value of concrete breakout strength by 0.6. All-lightweight concrete is beyond the scope of this table.

* See page 12 for an explanation of the load table icons.

Titen HD® Design Information — Concrete

Titen HD® Tension and Shear Strength Design Data for the Soffit of Normal-Weight or Sand-Lightweight Concrete over Metal Deck^{1,6,8}

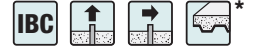

Characteristic	Symbol	Units	Nominal Anchor Diameter, d_a (in.)									
			Lower Flute				Upper Flute					
			Figure 2		Figure 1		Figure 2		Figure 1			
			$\frac{1}{4}^a$	$\frac{3}{8}$	$\frac{1}{2}$	$\frac{3}{4}$	$1\frac{1}{2}$	$1\frac{3}{4}$	2			
Nominal Embedment Depth	h_{nom}	in.	1 $\frac{1}{8}$	2 $\frac{1}{2}$	1 $\frac{7}{8}$	2 $\frac{1}{2}$	2	3 $\frac{1}{2}$	1 $\frac{5}{8}$	2 $\frac{1}{2}$	1 $\frac{7}{8}$	2
Effective Embedment Depth	h_{ef}	in.	1.19	1.94	1.23	1.77	1.29	2.56	1.19	1.94	1.23	1.29
Pullout Resistance, concrete on metal deck (cracked) ^{2,3,4}	$N_{p,deck,cr}$	lb.	420	535	375	870	905	2,040	655	1,195	500	1,700
Pullout Resistance, concrete on metal deck (uncracked) ^{2,3,4}	$N_{p,deck,uncr}$	lb.	995	1,275	825	1,905	1,295	2,910	1,555	2,850	1,095	2,430
Steel Strength in Shear, concrete on metal deck ⁵	$V_{sa,deck}$	lb.	1,335	1,745	2,240	2,395	2,435	4,430	2,010	2,420	4,180	7,145
Steel Strength in Shear, Seismic	$V_{sa,deck,eq}$	lb.	870	1,135	1,434	1,533	1,556	2,846	1,305	1,575	2,676	4,591

- The information presented in this table is to be used in conjunction with the design criteria of ACI 318 Appendix D, except as modified below.
- Concrete compressive strength shall be 3,000 psi minimum. The characteristic pullout resistance for greater compressive strengths shall be increased by multiplying the tabular value by $(f'_{c,specified} / 3,000)^{0.5}$.
- For anchors installed in the soffit of sand-lightweight or normal-weight concrete over metal deck floor and roof assemblies, as shown in Figure 1 and Figure 2, calculation of the concrete breakout strength may be omitted.
- In accordance with ACI 318 Section D.5.3.2, the nominal pullout strength in cracked concrete for anchors installed in the soffit of sand-lightweight or normal-weight concrete over metal deck floor and roof assemblies $N_{p,deck,cr}$

- shall be substituted for $N_{p,cr}$. Where analysis indicates no cracking at service loads, the normal pullout strength in uncracked concrete $N_{p,deck,uncr}$ shall be substituted for $N_{p,uncr}$.
- In accordance with ACI 318 Section D.6.1.2(c), the shear strength for anchors installed in the soffit of sand-lightweight or normal-weight concrete over metal deck floor and roof assemblies $V_{sa,deck}$ and $V_{sa,deck,eq}$ shall be substituted for V_{sa} .
- Minimum edge distance to edge of panel is $2h_{ef}$.
- The minimum anchor spacing along the flute must be the greater of $3h_{ef}$ or 1.5 times the flute width.
- Data for $\frac{1}{4}$ " anchor is valid only for THDB25 series.

Titen HD® Anchor Tension and Shear Strength Design Data in the Topside of Normal-Weight Concrete or Sand-Lightweight Concrete over Metal Deck



Design Information	Symbol	Units	Nominal Anchor Diameter, d_a	
			Figure 3	Figure 2
			$\frac{1}{4}$ "	$\frac{3}{8}$ "
Nominal Embedment Depth	h_{nom}	in.	1 $\frac{1}{8}$	2 $\frac{1}{2}$
Effective Embedment Depth	h_{ef}	in.	1.19	1.77
Minimum Concrete Thickness	$h_{min,deck}$	in.	2 $\frac{1}{2}$	3 $\frac{1}{4}$
Critical Edge Distance	$c_{ac,deck,top}$	in.	3 $\frac{3}{4}$	7 $\frac{1}{4}$
Minimum Edge Distance	$c_{min,deck,top}$	in.	3 $\frac{1}{2}$	3
Minimum Spacing	$s_{min,deck,top}$	in.	3 $\frac{1}{2}$	3

- For anchors installed in the topside of concrete-filled deck assemblies, as shown in Figures 2 and 3, the nominal concrete breakout strength of a single anchor or group of anchors in shear, V_{cp} or V_{cbg} , respectively, must be calculated in accordance with ACI 318 D.6.2, using the actual member thickness, $h_{min,deck}$, in the determination of A_{vc} .
- Design capacity shall be based on calculations according to values in the tables featured on pages 185 and 186.
- Minimum flute depth (distance from top of flute to bottom of flute) is 1 $\frac{1}{2}$ inch (see Figures 2 and 3).
- Steel deck thickness shall be minimum 20 gauge.
- Minimum concrete thickness ($h_{min,deck}$) refers to concrete thickness above upper flute (see Figures 2 and 3).

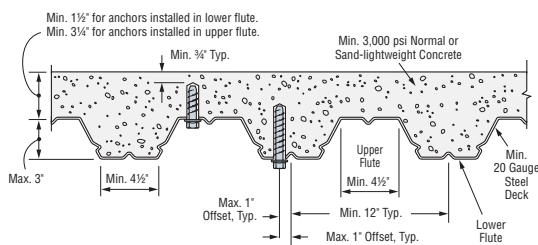

Figure 1. Installation of $\frac{3}{8}$ " and $\frac{1}{2}$ " Diameter Anchors in the Soffit of Concrete over Metal Deck

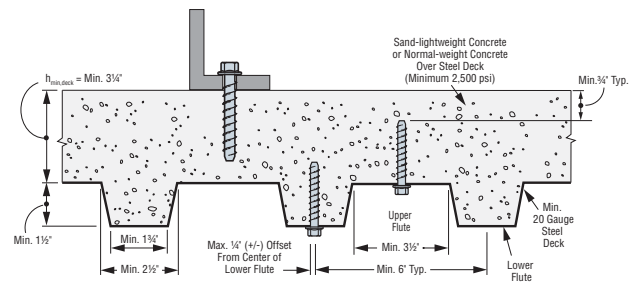

Figure 2. Installation of $\frac{3}{8}$ " Diameter Anchors in the Topside and $\frac{1}{4}$ " Diameter Anchors in the Soffit of Concrete over Metal Deck

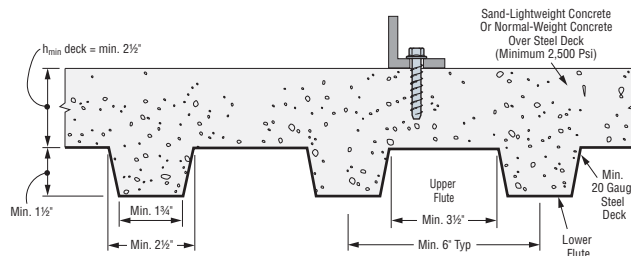

Figure 3. Installation of $\frac{1}{4}$ " Diameter Anchors in the Topside of Concrete over Metal Deck

* See page 12 for an explanation of the load table icons.

Titen HD® Design Information — Concrete



Titen HD® Tension Design Strengths in Normal-Weight Concrete ($f'_c = 2,500$ psi)

Anchor Dia. (in.)	Nominal Embed. Depth (in.)	Min. Concrete Thickness h_{min} (in.)	Critical Edge Distance c_{ac} (in.)	Minimum Edge Distance c_{min} (in.)	Tension Design Strength (lb.)							
					Edge Distances = c_{ac} on all sides				Edge Distances = c_{min} on one side and c_{ac} on three sides			
					SDC A-B ⁵		SDC C-F ^{6,7}		SDC A-B ⁵		SDC C-F ^{6,7}	
					Uncracked	Cracked	Uncracked	Cracked	Uncracked	Cracked	Uncracked	Cracked
1/4	1 5/8	3 1/4	3	1 1/2	1,265	715	950	540	660	630	495	470
	2 1/2	3 1/2	6	1 1/2	2,110	1,240	1,580	930	660	965	495	725
3/8	2 1/2	4	2 1/16	1 3/4	1,755	805	1,315	600	1,350	805	1,015	600
	3 1/4	5	3 3/8	1 3/4	2,900	1,755	2,175	1,315	1,810	1,290	1,360	970
1/2	3 1/4	5	3 9/16	1 3/4	2,810	1,990	2,105	1,495	1,765	1,265	1,325	950
	4	6 1/4	4 1/2	1 3/4	4,035	2,855	3,025	2,140	2,285	1,620	1,710	1,220
5/8	4	6	4 1/2	1 3/4	3,990	1,975	2,995	1,480	2,250	1,610	1,690	1,210
	5 1/2	8 1/2	6 3/8	1 3/4	6,375	3,620	4,780	2,715	3,390	2,405	2,540	1,805
3/4	5 1/2	8 3/4	6 3/8	1 3/4	6,760	3,945	5,070	2,960	3,355	2,395	2,515	1,795
	6 1/4	10	7 5/16	1 3/4	8,355	4,675	6,265	3,510	3,990	2,835	2,990	2,125

1. Tension design strengths are based on the strength design provisions of ACI 318-11 Appendix D.
2. Tabulated values are for a single anchor with no influence of another anchor.
3. Interpolation between embedment depths is not permitted.
4. Strength reduction factor, ϕ , is based on using a load combination from ACI 318-11 Section 9.2.
5. The tension design strength listed for SDC (Seismic Design Category) A-B may also be used in SDC C-F when the tension component of the strength-level seismic design load on the anchor does not exceed 20% of the total factored tension load on the anchor associated with the same load combination.
6. When designing anchorages in SDC C-F, the designer shall consider the ductility requirements of ACI 318-11 Section D.3.3.
7. Tension design strengths in SDC C-F have been adjusted by 0.75 factor in accordance with ACI 318-11 Section D.3.3.4.4.



Titen HD® Allowable Tension Loads in Normal-Weight Concrete ($f'_c = 2,500$ psi) — Static Load

Anchor Dia. (in.)	Nominal Embed. Depth (in.)	Min. Concrete Thickness h_{min} (in.)	Critical Edge Distance c_{ac} (in.)	Minimum Edge Distance c_{min} (in.)	Allowable Tension Load (lb.)			
					Edge Distances = c_{ac} on all sides		Edge Distances = c_{min} on one side and c_{ac} on three sides	
					Uncracked	Cracked	Uncracked	Cracked
1/4	1 5/8	3 1/4	3	1 1/2	905	510	470	450
	2 1/2	3 1/2	6	1 1/2	1,505	885	470	690
3/8	2 1/2	4	2 1/16	1 3/4	1,255	575	965	575
	3 1/4	5	3 3/8	1 3/4	2,070	1,255	1,295	920
1/2	3 1/4	5	3 9/16	1 3/4	2,005	1,420	1,260	905
	4	6 1/4	4 1/2	1 3/4	2,880	2,040	1,630	1,155
5/8	4	6	4 1/2	1 3/4	2,850	1,410	1,605	1,150
	5 1/2	8 1/2	6 3/8	1 3/4	4,555	2,585	2,420	1,720
3/4	5 1/2	8 3/4	6 3/8	1 3/4	4,830	2,820	2,395	1,710
	6 1/4	10	7 5/16	1 3/4	5,970	3,340	2,850	2,025

1. Allowable tension loads are calculated based on the strength design provision of ACI 318-11 Appendix D using a conversion factor of $\alpha = 1.4$. The conversion factor α is based on the load combination 1.2D + 1.6L assuming 50% dead load and 50% live load: $1.2(0.5) + 1.6(0.5) = 1.4$.
2. Tabulated values are for a single anchor with no influence of another anchor.
3. Interpolation between embedment depths is not permitted.



Titen HD® Allowable Tension Loads in Normal-Weight Concrete ($f'_c = 2,500$ psi) — Wind Load

Anchor Dia. (in.)	Nominal Embed. Depth (in.)	Min. Concrete Thickness h_{min} (in.)	Critical Edge Distance c_{ac} (in.)	Minimum Edge Distance c_{min} (in.)	Allowable Tension Load (lb.)			
					Edge Distances = c_{ac} on all sides		Edge Distances = c_{min} on one side and c_{ac} on three sides	
					Uncracked	Cracked	Uncracked	Cracked
1/4	1 5/8	3 1/4	3	1 1/2	760	430	395	380
	2 1/2	3 1/2	6	1 1/2	1,265	745	395	580
3/8	2 1/2	4	2 1/16	1 3/4	1,055	485	810	485
	3 1/4	5	3 3/8	1 3/4	1,740	1,055	1,085	775
1/2	3 1/4	5	3 9/16	1 3/4	1,685	1,195	1,060	760
	4	6 1/4	4 1/2	1 3/4	2,420	1,715	1,370	970
5/8	4	6	4 1/2	1 3/4	2,395	1,185	1,350	965
	5 1/2	8 1/2	6 3/8	1 3/4	3,825	2,170	2,035	1,445
3/4	5 1/2	8 3/4	6 3/8	1 3/4	4,055	2,365	2,015	1,435
	6 1/4	10	7 5/16	1 3/4	5,015	2,805	2,395	1,700

1. Allowable tension loads are calculated based on the strength design provision of ACI 318-11 Appendix D using a conversion factor of $\alpha = 1.67$. The conversion factor α is based on the load combination assuming 100% wind load.
2. Tabulated values are for a single anchor with no influence of another anchor.
3. Interpolation between embedment depths is not permitted.

* See page 12 for an explanation of the load table icons.

Titen HD® Design Information — Concrete

Titen HD® Allowable Tension Loads in Normal-Weight Concrete
($f'_c = 2,500$ psi) — Seismic Load

Anchor Dia. (in.)	Nominal Embed. Depth (in.)	Min. Concrete Thickness h_{min} (in.)	Critical Edge Distance c_{ac} (in.)	Minimum Edge Distance c_{min} (in.)	Allowable Tension Load (lb.)							
					Edge Distances = c_{ac} on all sides				Edge Distances = c_{min} on one side and c_{ac} on three sides			
					SDC A-B ⁴		SDC C-F ^{5,6}		SDC A-B ⁴		SDC C-F ^{5,6}	
					Uncracked	Cracked	Uncracked	Cracked	Uncracked	Cracked	Uncracked	Cracked
1/4	1 5/8	3 1/4	3	1 1/2	885	500	665	380	460	440	345	330
	2 1/2	3 1/2	6	1 1/2	1,475	870	1,105	650	460	675	345	510
3/8	2 1/2	4	2 11/16	1 3/4	1,230	565	920	420	945	565	710	420
	3 1/4	5	3 5/8	1 3/4	2,030	1,230	1,525	920	1,265	905	950	680
1/2	3 1/4	5	3 3/16	1 3/4	1,965	1,395	1,475	1,045	1,235	885	930	665
	4	6 1/4	4 1/2	1 3/4	2,825	2,000	2,120	1,500	1,600	1,135	1,195	855
5/8	4	6	4 1/2	1 3/4	2,795	1,385	2,095	1,035	1,575	1,125	1,185	845
	5 1/2	8 1/2	6 3/8	1 3/4	4,465	2,535	3,345	1,900	2,375	1,685	1,780	1,265
3/4	5 1/2	8 3/4	6 3/8	1 3/4	4,730	2,760	3,550	2,070	2,350	1,675	1,760	1,255
	6 1/4	10	7 5/16	1 3/4	5,850	3,275	4,385	2,455	2,795	1,985	2,095	1,490

1. Allowable tension loads are calculated based on the strength design provision of ACI 318-11 Appendix D using a conversion factor of $\alpha = 1/0.7 = 1.43$. The conversion factor α is based on the load combination assuming 100% seismic load.

2. Tabulated values are for a single anchor with no influence of another anchor.

3. Interpolation between embedment depths is not permitted.

4. The allowable tension load listed for SDC (Seismic Design Category) A-B may also be used in SDC C-F when the tension component of the strength-level seismic design load on the anchor does not exceed 20% of the total factored tension load on the anchor associated with the same load combination.

5. When designing anchorages in SDC C-F, the designer shall consider the ductility requirements of ACI 318-11 Section D.3.3.

6. Tension design strengths in SDC C-F have been adjusted by 0.75 factor in accordance with ACI 318-11 Section D.3.3.4.4.

Titen HD® Design Information — Concrete

Titen HD® Tension Design Strengths in Soffit of Normal-Weight or Sand-Lightweight Concrete-Filled Profile Steel Deck Assemblies ($f'_c = 3,000$ psi)



Anchor Dia. (in.)	Nominal Embed. Depth (in.)	Minimum End Distance c_{min} (in.)	Tension Design Strength (lb.)							
			Lower Flute				Upper Flute			
			SDC A-B ⁵		SDC C-F ^{6,7}		SDC A-B ⁵		SDC C-F ^{6,7}	
Uncracked	Cracked	Uncracked	Cracked	Uncracked	Cracked	Uncracked	Cracked			
1/4	1 5/8	2 1/2	645	275	485	205	1,010	425	760	320
	2 1/2	4	830	350	620	260	1,855	775	1,390	585
3/8	1 7/8	2 1/2	535	245	400	185	710	325	535	245
	2 1/2	3 5/8	1,240	565	930	425	—	—	—	—
1/2	2	2 5/8	840	590	630	440	1,580	1,105	1,185	830
	3 1/2	5 1/4	1,890	1,325	1,420	995	—	—	—	—

1. Tension design strengths are based on the strength design provisions of ACI 318-11 Appendix D.
2. Tabulated values are for a single anchor with no influence of another anchor.
3. Interpolation between embedment depths is not permitted.
4. Strength reduction factor, ϕ , is based on using a load combination from ACI 318-11 Section 9.2.
5. The tension design strength listed for SDC (Seismic Design Category) A-B may also be used in SDC C-F when the tension component of the strength-level seismic design load on the anchor does not exceed 20% of the total factored tension load on the anchor associated with the same load combination.
6. When designing anchorages in SDC C-F, the designer shall consider the ductility requirements of ACI 318-11 Section D.3.3.
7. Tension design strengths in SDC C-F have been adjusted by 0.75 factor in accordance with ACI 318-11 Section D.3.3.4.4.
8. Installation must comply with Figure 1 on page 187.

Titen HD® Allowable Tension Loads in Soffit of Normal-Weight or Sand-Lightweight Concrete-Filled Profile Steel Deck Assemblies ($f'_c = 3,000$ psi) — Static Load



Anchor Dia. (in.)	Nominal Embed. Depth (in.)	Minimum End Distance c_{min} (in.)	Allowable Tension Load (lb.)			
			Lower Flute		Upper Flute	
			Uncracked	Cracked	Uncracked	Cracked
1/4	1 5/8	2 1/2	460	195	720	305
	2 1/2	4	595	250	1,325	555
3/8	1 7/8	2 1/2	380	175	505	230
	2 1/2	3 5/8	885	405	—	—
1/2	2	2 5/8	600	420	1,130	790
	3 1/2	5 1/4	1,350	945	—	—

1. Allowable tension loads are calculated based on the strength design provision of ACI 318-11 Appendix D using a conversion factor of $\alpha = 1.4$. The conversion factor α is based on the load combination 1.2D + 1.6L assuming 50% dead load and 50% live load: $1.2(0.5) + 1.6(0.5) = 1.4$.
2. Tabulated values are for a single anchor with no influence of another anchor.
3. Interpolation between embedment depths is not permitted.
4. Installation must comply with Figure 1 on page 187.

Titen HD® Allowable Tension Loads in Soffit of Normal-Weight or Sand-Lightweight Concrete-Filled Profile Steel Deck Assemblies ($f'_c = 3,000$ psi) — Wind Load



Anchor Dia. (in.)	Nominal Embed. Depth (in.)	Minimum End Distance c_{min} (in.)	Allowable Tension Load (lb.)			
			Lower Flute		Upper Flute	
			Uncracked	Cracked	Uncracked	Cracked
1/4	1 5/8	2 1/2	385	165	605	255
	2 1/2	4	500	210	1,115	465
3/8	1 7/8	2 1/2	320	145	425	195
	2 1/2	3 5/8	745	340	—	—
1/2	2	2 5/8	505	355	950	665
	3 1/2	5 1/4	1,135	795	—	—

1. Allowable tension loads are calculated based on the strength design provision of ACI 318-11 Appendix D using a conversion factor of $\alpha = 1.67$. The conversion factor α is based on the load combination assuming 100% wind load.
2. Tabulated values are for a single anchor with no influence of another anchor.
3. Interpolation between embedment depths is not permitted.
4. Installation must comply with Figure 1 on page 187.

* See page 12 for an explanation of the load table icons.

Titen HD® Design Information — Concrete

Titen HD® Allowable Tension Loads in Soffit of Normal-Weight or Sand-Lightweight Concrete-Filled Profile Steel Deck Assemblies ($f'_c = 3,000$ psi) — Seismic Load

Anchor Dia. (in.)	Nominal Embed. Depth (in.)	Minimum End Distance C_{min} (in.)	Allowable Tension Load (lb.)							
			Lower Flute				Upper Flute			
			SDC A-B ⁴		SDC C-F ^{5,6}		SDC A-B ⁴		SDC C-F ^{5,6}	
Uncracked	Cracked	Uncracked	Cracked	Uncracked	Cracked	Uncracked	Cracked			
¼	1 ⅝	2 ½	450	195	340	145	705	300	530	225
	2 ½	4	580	245	435	180	1300	545	975	410
⅜	1 ⅞	2 ½	375	170	280	130	495	230	375	170
	2 ½	3 ⅝	870	395	650	300	—	—	—	—
½	2	2 ⅝	590	415	440	310	1105	775	830	580
	3 ½	5 ¼	1325	930	995	695	—	—	—	—

1. Allowable tension loads are calculated based on the strength design provision of ACI 318-11 Appendix D using a conversion factor of $\alpha = 1/0.7 = 1.43$. The conversion factor α is based on the load combination assuming 100% seismic load.
2. Tabulated values are for a single anchor with no influence of another anchor.
3. Interpolation between embedment depths is not permitted.
4. The allowable tension load listed for SDC (Seismic Design Category) A-B may also be used in SDC C-F when the tension component of the strength-level seismic design load on the anchor does not exceed 20% of the total factored tension load on the anchor associated with the same load combination.
5. When designing anchorages in SDC C-F, the designer shall consider the ductility requirements of ACI 318-11 Section D.3.3.
6. Tension design strengths in SDC C-F have been adjusted by 0.75 factor in accordance with ACI 318-11 Section D.3.3.4.4.
7. Installation must comply with Figure 1 on page 187.

* See page 12 for an explanation of the load table icons.

Titen HD® Design Information — Concrete



Titen HD® Allowable Tension Loads in Normal-Weight Concrete

Mechanical Anchors

Size (in.)	Drill Bit Dia. (in.)	Embed. Depth in. (mm)	Critical Edge Dist. in. (mm)	Critical Spacing in. (mm)	Tension Load						
					f'c ≥ 2,000 psi (13.8 MPa Concrete)			f'c ≥ 3,000 psi (20.7 MPa Concrete)		f'c ≥ 4,000 psi (27.6 MPa Concrete)	
					Ultimate lb. (kN)	Std. Dev. lb. (kN)	Allowable lb. (kN)	Allowable lb. (kN)	Ultimate lb. (kN)	Std. Dev. lb. (kN)	Allowable lb. (kN)
3/8 (9.5)	3/8	1 1/2 (38)	6 (152)	4 (102)	2,070 (9.2)	—	520 (2.3)	635 (2.8)	2,974 (13.2)	—	745 (3.3)
		2 3/4 (70)	3 (76)	6 (152)	4,297 (19.1)	—	1,075 (4.8)	1,315 (5.8)	6,204 (27.6)	—	1,550 (6.9)
		3 3/4 (95)			7,087 (31.5)	347 (1.5)	1,770 (7.9)	2,115 (9.4)	9,820 (43.7)	1,434 (6.4)	2,455 (10.9)
1/2 (12.7)	1/2	2 3/4 (70)	4 (102)	8 (203)	4,610 (20.5)	—	1,155 (5.1)	1,400 (6.2)	6,580 (29.3)	—	1,645 (7.3)
		3 3/8 (92)			7,413 (33.0)	412 (1.8)	1,855 (8.3)	2,270 (10.1)	10,742 (47.8)	600 (2.7)	2,685 (11.9)
		5 3/4 (146)			10,278 (45.7)	297 (1.3)	2,570 (11.4)	3,240 (14.4)	15,640 (69.6)	2,341 (10.4)	3,910 (17.4)
5/8 (15.9)	5/8	2 3/4 (70)	5 (127)	10 (254)	4,610 (20.5)	—	1,155 (5.1)	1,400 (6.2)	6,580 (29.3)	—	1,645 (7.3)
		4 1/8 (105)			8,742 (38.9)	615 (2.7)	2,185 (9.7)	2,630 (11.7)	12,286 (54.7)	1,604 (7.1)	3,070 (13.7)
		5 3/4 (146)			12,953 (57.6)	1,764 (7.8)	3,240 (14.4)	3,955 (17.6)	18,680 (83.1)	—	4,670 (20.8)
3/4 (19.1)	3/4	2 3/4 (70)	6 (152)	12 (305)	4,674 (20.8)	—	1,170 (5.2)	1,405 (6.3)	6,580 (29.3)	—	1,645 (7.3)
		4 5/8 (117)			10,340 (46.0)	1,096 (4.9)	2,585 (11.5)	3,470 (15.4)	17,426 (77.5)	1,591 (7.1)	4,355 (19.4)
		5 3/4 (146)			13,765 (61.2)	1,016 (4.5)	3,440 (15.3)	4,055 (18.0)	18,680 (83.1)	1,743 (7.8)	4,670 (20.8)

- The allowable loads listed are based on a safety factor of 4.0.
- Refer to allowable load-adjustment factors for spacing and edge distance on pages 198 and 199.
- The minimum concrete thickness is 1 1/2 times the embedment depth.
- Tension and shear loads for the Titen HD anchor may be combined using the elliptical interaction equation (n=5/6). Allowable load may be interpolated for concrete compressive strengths between 2,000 psi and 4,000 psi.



Titen HD® Allowable Shear Loads in Normal-Weight Concrete

Size (in.)	Drill Bit Dia. (in.)	Embed. Depth in. (mm)	Critical Edge Dist. in. (mm)	Critical Spacing in. (mm)	Shear Load						
					f'c ≥ 2,000 psi (13.8 MPa Concrete)			f'c ≥ 3,000 psi (20.7 MPa Concrete)		f'c ≥ 4,000 psi (27.6 MPa Concrete)	
					Ultimate lb. (kN)	Std. Dev. lb. (kN)	Allowable lb. (kN)	Allowable lb. (kN)	Ultimate lb. (kN)	Std. Dev. lb. (kN)	Allowable lb. (kN)
3/8 (9.5)	3/8	1 1/2 (38)	6 (152)	4 (102)	2,912 (13.0)	—	730 (3.2)	825 (3.7)	3,668 (16.3)	—	915 (4.1)
		2 3/4 (70)	4 1/2 (114)	6 (152)	6,353 (28.3)	—	1,585 (7.1)	1,665 (7.4)	—	—	1,740 (7.7)
		3 3/4 (95)			6,377 (28.4)	1,006 (4.5)	1,595 (7.1)	1,670 (7.4)	—	1,740 (7.7)	
1/2 (12.7)	1/2	2 3/4 (70)	6 (152)	8 (203)	6,435 (28.6)	—	1,605 (7.1)	2,050 (9.1)	9,987 (44.4)	—	2,495 (7.8)
		3 3/8 (92)			9,324 (41.5)	1,285 (5.7)	2,330 (10.4)	2,795 (12.4)	13,027 (57.9)	597 (2.7)	3,255 (14.5)
		5 3/4 (146)			11,319 (50.3)	1,245 (5.5)	2,830 (12.6)	3,045 (13.5)	—	—	3,255 (14.5)
5/8 (15.9)	5/8	2 3/4 (70)	7 1/2 (191)	10 (254)	7,745 (34.5)	—	1,940 (8.6)	2,220 (9.9)	9,987 (44.4)	—	2,495 (7.8)
		4 1/8 (105)			8,706 (38.7)	1,830 (8.1)	2,175 (9.7)	3,415 (15.2)	18,607 (82.8)	1,650 (7.3)	4,650 (20.7)
		5 3/4 (146)			12,498 (55.6)	2,227 (9.9)	3,125 (13.9)	3,890 (17.3)	—	—	4,650 (20.7)
3/4 (19.1)	3/4	2 3/4 (70)	9 (229)	12 (305)	7,832 (34.8)	—	1,960 (8.7)	2,415 (10.7)	11,460 (51.0)	—	2,865 (12.7)
		4 5/8 (117)			11,222 (49.9)	2,900 (12.9)	2,805 (12.5)	4,490 (20.0)	24,680 (109.8)	2,368 (10.5)	6,170 (27.4)
		5 3/4 (146)			19,793 (88.0)	3,547 (15.8)	4,950 (22.0)	5,560 (24.7)	24,680 (109.8)	795 (3.5)	6,170 (27.4)

- The allowable loads listed are based on a safety factor of 4.0.
- Refer to allowable load-adjustment factors for spacing and edge distance on pages 198 and 199.
- The minimum concrete thickness is 1 1/2 times the embedment depth.
- Tension and shear loads for the Titen HD anchor may be combined using the elliptical interaction equation (n=5/6). Allowable load may be interpolated for concrete compressive strengths between 2,000 psi and 4,000 psi.

* See page 12 for an explanation of the load table icons.

Titen HD® Design Information — Concrete

Titen HD® Allowable Shear Loads in Normal-Weight Concrete, Load Applied Parallel to Concrete Edge   *

Size in. (mm)	Drill Bit Dia. in.	Embed. Depth in. (mm)	Minimum Edge Dist. in. (mm)	Minimum End Dist. in. (mm)	Minimum Spacing Dist. in. (mm)	Shear Load Based on Concrete Edge Distance		
						f'c ≥ 2,500 psi (17.2 MPa) Concrete		
						Ultimate lb. (kN)	Std. Dev. lb. (kN)	Allowable lb. (kN)
1/2 (12.7)	1/2	2 3/4 (70)	1 3/4 (45)	8 (203)	8 (203)	4,660 (20.7)	575 (2.6)	1,165 (5.2)
		3 1/4 (83)				—	1,530 (6.8)	
		3 1/2 (89)				6,840 (30.4)	860 (3.8)	1,710 (7.6)
		4 1/2 (114)				7,800 (34.7)	300 (1.3)	1,950 (8.7)
5/8 (15.9)	5/8	2 3/4 (70)	1 3/4 (45)	10 (254)	10 (254)	4,820 (21.4)	585 (2.6)	1,205 (5.3)
		3 1/4 (83)				—	1,580 (7.0)	
		3 1/2 (89)				7,060 (31.4)	1,284 (5.7)	1,765 (7.9)

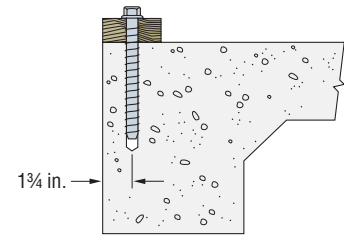

Note: Rebar not shown for clarity.

1. The allowable loads listed are based on a safety factor of 4.0.
2. The minimum concrete thickness is 1 1/2 times the embedment depth.

Titen HD® Allowable Tension Loads in Normal-Weight Concrete Stemwall   *

Size in. (mm)	Drill Bit Dia. in.	Embed. Depth in. (mm)	Stemwall Width in. (mm)	Min. Edge Dist. in. (mm)	Min. End Dist. in. (mm)	Tension Load			
						f'c ≥ 2,500 psi (17.2 MPa) Concrete		f'c ≥ 4,500 psi (31.0 MPa) Concrete	
						Ultimate lb. (kN)	Allow. lb. (kN)	Ultimate lb. (kN)	Allow. lb. (kN)
1/2 (12.7)	1/2	10 (254)	6 (152)	1 3/4 (45)	8 (203)	15,420 (68.6)	3,855 (17.1)	20,300 (90.3)	5,075 (22.6)
					4 3/8 (111)	14,280 (63.5)	3,570 (15.9)	19,040 (84.7)	4,760 (21.2)

1. The allowable loads are based on a safety factor of 4.0.
2. The minimum anchor spacing is 15 inches.
3. The minimum concrete thickness (depth) is 12 inches.
4. Allowable loads may be interpolated for compressive strengths between 2,500 and 4,500 psi.

Titen HD® Allowable Tension Loads in Normal-Weight Concrete, Load Applied at 60° Angle to Horizontal for Tilt-Up Wall Braces   *

Size in. (mm)	Drill Bit Dia. in.	Embed. Depth in. (mm)	Tension Applied at 60 degrees to Horizontal		
			f'c ≥ 2,500 psi (17.2 MPa) Concrete		
			Ultimate lb. (kN)	Std. Dev. lb. (kN)	Allow. lb. (kN)
5/8 (15.9)	5/8	5 (127)	13,420 (59.7)	1,273 (5.7)	3,355 (14.9)
3/4 (19.1)	3/4	5 (127)	15,180 (67.5)	968 (4.3)	3,795 (16.9)

1. The allowable loads are based on a safety factor of 4.0.
2. Anchor must be installed into a concrete floor slab, footing, or deadman with sufficient area, weight, and strength to resist the anchorage load.
3. Titen HD® has been qualified for temporary outdoor use of up to 90 days through testing for this application.



The Titen HD® screw anchor 3/4" x 6" and 3/4" x 7" (models THDT75600H and THD75700H) have a 1" section under the head that is unthreaded to allow installation into tilt-up wall braces.

* See page 12 for an explanation of the load table icons.

Titen HD® Design Information — Concrete



Titen HD® Allowable Tension and Shear Loads in Sand-Lightweight Concrete over Metal Deck

Mechanical Anchors

Size in. (mm)	Drill Bit Dia. in.	Embed. Depth in. (mm)	Critical Edge Dist. in. (mm)	Critical Spacing Dist. in. (mm)	Install in Concrete (see Figure below)				Install through Metal Deck (see Figure below)			
					Tension Load		Shear Load		Tension Load		Shear Load	
					$f'_c \geq 3,000$ psi (20.7 MPa) Lightweight Concrete		$f'_c \geq 3,000$ psi (20.7 MPa) Lightweight Concrete		$f'_c \geq 3,000$ psi (20.7 MPa) Lightweight Concrete		$f'_c \geq 3,000$ psi (20.7 MPa) Lightweight Concrete	
					Ultimate lb. (kN)	Allowable lb. (kN)	Ultimate lb. (kN)	Allowable lb. (kN)	Ultimate lb. (kN)	Allowable lbs. (kN)	Ultimate lb. (kN)	Allowable lb. (kN)
3/8 (9.5)	3/8	2 3/4 (70)	6 (152)	6 (152)	2,560 (11.4)	640 (2.8)	4,240 (18.9)	1,060 (4.7)	—	—	—	—
		3 (76)			—	—	—	—	5,420 (24.1)	1,355 (6.0)	4,100 (18.2)	1,025 (4.6)
1/2 (12.7)	1/2	2 3/4 (70)	8 (203)	8 (203)	3,040 (13.5)	760 (3.4)	6,380 (28.4)	1,595 (7.1)	—	—	—	—
		4 (102)			—	—	—	—	7,020 (31.2)	1,755 (7.8)	6,840 (30.4)	1,710 (7.6)
5/8 (15.9)	5/8	2 3/4 (70)	10 (254)	10 (254)	3,100 (13.8)	775 (3.4)	6,380 (28.4)	1,595 (7.1)	—	—	—	—
		5 (127)			—	—	—	—	8,940 (39.8)	2,235 (9.9)	10,700 (47.6)	2,675 (11.9)

- The allowable loads listed are based on a safety factor of 4.0.
- Allowable loads for anchors installed in the lower flute of the steel deck are for flutes with a trapezoidal profile with a depth of 3 inches, and a width varying from 4 1/2 inches at the bottom to 7 1/2 inches at the top. The spacing of the flutes is 12 inches. The metal deck must be minimum 20-gauge with a minimum yield strength of 38 ksi and minimum ultimate strength of 45 ksi.
- Anchors may be installed off-center in the lower flute (up to 1 1/2" from the edge of the lower flute) without a load reduction.
- 100% of the allowable load is permitted at critical edge distance and critical spacing. Testing at smaller edge distances and spacings has not been performed.

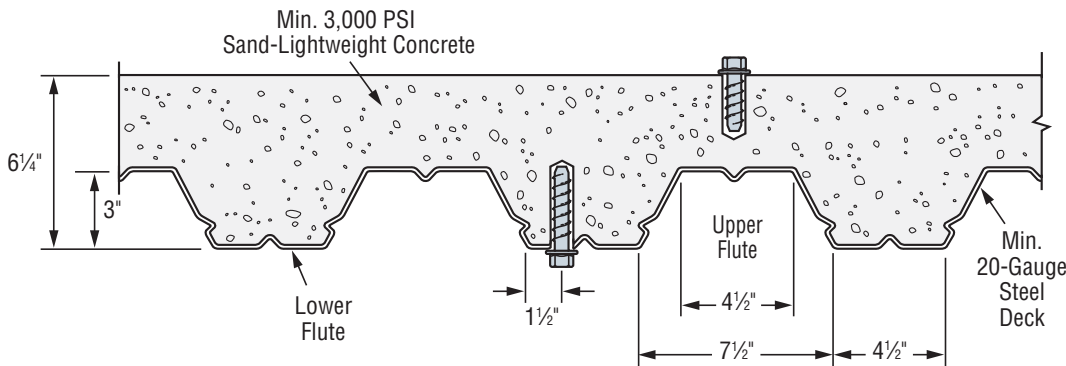

Titen HD® screw anchor installed in the top and bottom of a structural sand-lightweight-concrete and metal-deck assembly

* See page 12 for an explanation of the load table icons.

Titen HD® Design Information — Masonry

Titen HD® Allowable Tension and Shear Loads
in 8" Lightweight, Medium-Weight and Normal-Weight
Grout-Filled CMU

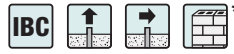

Size in. (mm)	Drill Bit Dia. in.	Min. Embed. Depth in. (mm)	Critical Edge Dist. in. (mm)	Critical End Dist. in. (mm)	Critical Spacing Dist. in. (mm)	Values for 8-inch Lightweight, Medium-Weight or Normal-Weight Grout-Filled CMU			
						Tension Load		Shear Load	
						Ultimate lb. (kN)	Allowable lb. (kN)	Ultimate lb. (kN)	Allowable lb. (kN)
Anchor Installed in the Face of the CMU Wall (See Figure 4)									
3/8 (9.5)	3/8	2 3/4 (70)	12 (305)	12 (305)	6 (152)	2,390 (10.6)	480 (2.1)	4,340 (19.3)	870 (3.9)
1/2 (12.7)	1/2	3 1/2 (89)	12 (305)	12 (305)	8 (203)	3,440 (15.3)	690 (3.1)	6,920 (30.8)	1,385 (6.2)
5/8 (15.9)	5/8	4 1/2 (114)	12 (305)	12 (305)	10 (254)	5,300 (23.6)	1,060 (4.7)	10,420 (46.4)	2,085 (9.3)
3/4 (19.1)	3/4	5 1/2 (140)	12 (305)	12 (305)	12 (305)	7,990 (35.5)	1,600 (7.1)	15,000 (66.7)	3,000 (13.3)

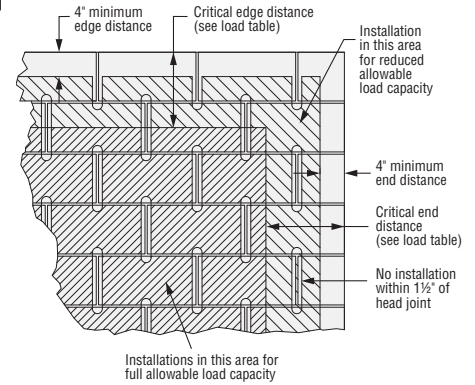
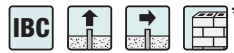

Figure 4. Shaded Area = Placement for Full and Reduced Allowable Load Capacity in Grout-Filled CMU

1. The tabulated allowable loads are based on a safety factor of 5.0 for installations under the IBC and IRC.
2. Values for 8-inch-wide, lightweight, medium-weight and normal-weight concrete masonry units.
3. The masonry units must be fully grouted.
4. The minimum specified compressive strength of masonry, f'_m , at 28 days is 1,500 psi.
5. Embedment depth is measured from the outside face of the concrete masonry unit.
6. Allowable loads may be increased 33 1/3% for short-term loading due to wind or seismic forces where permitted by code.
7. Grout-filled CMU wall design must satisfy applicable design standards and be capable of withstanding applied loads.
8. Refer to allowable load-adjustment factors for spacing and edge distance on page 200.

Titen HD® Allowable Tension and Shear Loads
in 8" Lightweight, Medium-Weight and
Normal-Weight Hollow CMU



Size in. (mm)	Drill Bit Dia. in.	Embed. Depth ⁴ in. (mm)	Min. Edge Dist. in. (mm)	Min. End Dist. in. (mm)	8-inch Hollow CMU Loads Based on CMU Strength			
					Tension Load		Shear Load	
					Ultimate lb. (kN)	Allowable lb. (kN)	Ultimate lb. (kN)	Allowable lb. (kN)
Anchor Installed in Face Shell (See Figure 5)								
3/8 (9.5)	3/8	1 3/4 (45)	4 (102)	4 5/8 (117)	720 (3.2)	145 (0.6)	1,240 (5.5)	250 (1.1)
1/2 (12.7)	1/2	1 3/4 (45)	4 (102)	4 5/8 (117)	760 (3.4)	150 (0.7)	1,240 (5.5)	250 (1.1)
5/8 (15.9)	5/8	1 3/4 (45)	4 (102)	4 5/8 (117)	800 (3.6)	160 (0.7)	1,240 (5.5)	250 (1.1)
3/4 (19.1)	3/4	1 3/4 (45)	4 (102)	4 5/8 (117)	880 (3.9)	175 (0.8)	1,240 (5.5)	250 (1.1)

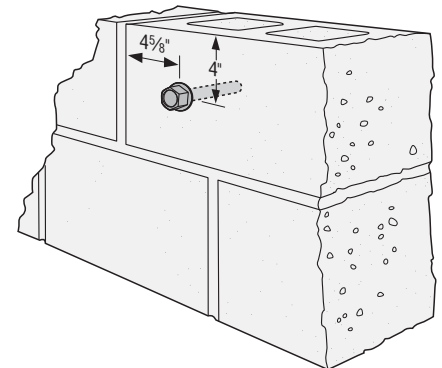

Figure 5

1. The tabulated allowable loads are based on a safety factor of 5.0 for installations under the IBC and IRC.
2. Values for 8-inch-wide, lightweight, medium-weight and normal-weight concrete masonry units.
3. The minimum specified compressive strength of masonry, f'_m , at 28 days is 1,500 psi.
4. Embedment depth is measured from the outside face of the concrete masonry unit and is based on the anchor being embedded an additional 1/2" through 1 1/4" thick face shell.
5. Allowable loads may not be increased for short-term loading due to wind or seismic forces. CMU wall design must satisfy applicable design standards and be capable of withstanding applied loads.
6. Do not use impact wrenches to install in hollow CMU.
7. Set drill to rotation-only mode when drilling into hollow CMU.

* See page 12 for an explanation of the load table icons.

Titen HD® Design Information — Masonry

Titen HD® Allowable Tension and Shear Loads in 8" Lightweight, Medium-Weight and Normal-Weight Grout-Filled CMU Stemwall



Size in. (mm)	Drill Bit Dia. in.	Embed. Depth in. (mm)	Min. Edge Dist. in. (mm)	Min. End Dist. in. (mm)	Critical Spacing Dist. in. (mm)	8-inch Grout-Filled CMU Allowable Loads Based on CMU Strength					
						Tension		Shear Perp. to Edge		Shear Parallel to Edge	
						Ultimate lb. (kN)	Allowable lb. (kN)	Ultimate lb. (kN)	Allowable lb. (kN)	Ultimate lb. (kN)	Allowable lb. (kN)
Anchor Installed in Cell Opening or Web (Top of Wall) (See Figure 6)											
½ (12.7)	½	4½ (114)	1¼ (45)	8 (203)	8 (203)	2,860 (12.7)	570 (2.5)	800 (3.6)	160 (0.7)	2,920 (13.0)	585 (2.6)
⅝ (15.9)	⅝	4½ (114)	1¼ (45)	10 (254)	10 (254)	2,860 (12.7)	570 (2.5)	800 (3.6)	160 (0.7)	3,380 (15.0)	675 (3.0)

1. The tabulated allowable loads are based on a safety factor of 5.0 for installations under the IBC and IRC.
2. Values are for 8-inch-wide, lightweight, medium-weight and normal-weight concrete masonry units.
3. The masonry units must be fully grouted.
4. The minimum specified compressive strength of masonry, f'_m , at 28 days is 1,500 psi.
5. Allowable loads may be increased 33⅓% for short-term loading due to wind or seismic forces where permitted by code.
6. Grout-filled CMU wall design must satisfy applicable design standards and be capable of withstanding applied design loads.
7. Loads are based on anchor installed in either the web or grout-filled cell opening in the top of wall.

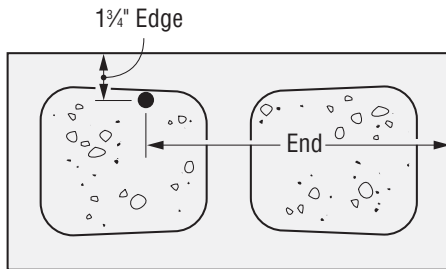

Figure 6. Anchor Installed in top of wall

* See page 12 for an explanation of the load table icons.

Titen HD® Design Information — Masonry

Titen HD® Allowable Tension Loads for 8" Lightweight, Medium-Weight and Normal-Weight CMU Chair Blocks Filled with Normal-Weight Concrete



Size in. (mm)	Drill Bit Dia. (in.)	Min. Embed. Depth in. (mm)	Min. Edge Dist. in. (mm)	Critical Spacing in. (mm)	8-inch Concrete-Filled CMU Chair Block Allowable Tension Loads Based on CMU Strength	
					Ultimate lb. (kN)	Allowable lb. (kN)
3/8 (9.5)	3/8	2 3/8 (60)	1 3/4 (44)	9 1/2 (241)	3,175 (14.1)	635 (2.8)
		3 3/8 (86)	1 3/4 (44)	13 1/2 (343)	5,175 (23.0)	1,035 (4.6)
		5 (127)	2 1/4 (57)	20 (508)	10,584 (47.1)	2,115 (9.4)
1/2 (12.7)	1/2	8 (203)	2 1/4 (57)	32 (813)	13,722 (61.0)	2,754 (12.2)
		10 (254)	2 1/4 (57)	40 (1016)	16,630 (74.0)	3,325 (14.8)
5/8 (15.9)	5/8	5 1/2 (140)	1 3/4 (44)	22 (559)	9,025 (40.1)	1,805 (8.1)
		12 (305)	2 1/4 (57)	48 (1219)	18,104 (80.5)	3,620 (16.1)

1. The tabulated allowable loads are based on a safety factor of 5.0.
2. Values are for 8-inch-wide concrete masonry units (CMU) filled with concrete, with minimum compressive strength of 2,500 psi and poured monolithically with the floor slab.
3. Center #5 rebar in CMU cell and concrete slab as shown in the illustration below.

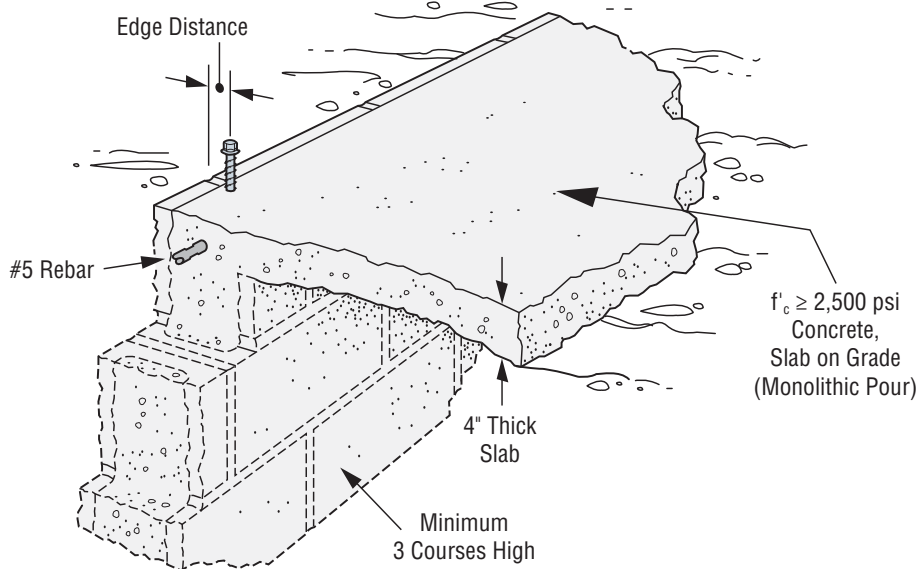

C-A-2016 © 2015 SIMPSON STRONG-TIE COMPANY INC.

Mechanical Anchors

* See page 12 for an explanation of the load table icons.

Titen HD® Design Information — Concrete

Load Adjustment Factors for Titen HD® Anchors in Normal-Weight Concrete:
Edge Distance, Tension and Shear Loads

How to use these charts:

1. The following tables are for reduced edge distance.
2. Locate the anchor size to be used for either a tension and/or shear load application.
3. Locate the anchor embedment (E) used for either a tension and/or shear load application.
4. Locate the edge distance (c_{act}) at which the anchor is to be installed.
5. The load adjustment factor (f_c) is the intersection of the row and column.
6. Multiply the allowable load by the applicable load adjustment factor(s).
7. Reduction factors for multiple edges are multiplied together.



Edge Distance Tension (f_c)

Edge Dist. c_{act} (in.)	Dia.	3/8			1/2			5/8			3/4		
	E	1 1/2	2 3/4	3 3/4	2 3/4	3 3/8	5 3/4	2 3/4	4 1/8	5 3/4	2 3/4	4 3/8	5 3/4
	c_{cr}	6	3	3	4	4	4	5	5	5	6	6	6
	c_{min}	6	1 3/4	1 3/4	1 3/4	1 3/4	1 3/4	1 3/4	1 3/4	1 3/4	1 3/4	1 3/4	1 3/4
f_{cmin}	1.00	0.83	0.73	0.67	0.57	0.73	0.67	0.57	0.57	0.59	0.67	0.48	0.58
1 3/4			0.83	0.73	0.67	0.57	0.73	0.67	0.57	0.59	0.67	0.48	0.58
2			0.86	0.78	0.71	0.62	0.76	0.70	0.60	0.62	0.69	0.51	0.60
2 1/4			0.90	0.84	0.74	0.67	0.79	0.72	0.64	0.65	0.71	0.54	0.63
2 1/2			0.93	0.89	0.78	0.71	0.82	0.75	0.67	0.68	0.73	0.57	0.65
2 3/4			0.97	0.95	0.82	0.76	0.85	0.77	0.70	0.72	0.75	0.60	0.68
3			1.00	1.00	0.85	0.81	0.88	0.80	0.74	0.75	0.77	0.63	0.70
3 1/4					0.89	0.86	0.91	0.82	0.77	0.78	0.79	0.66	0.73
3 1/2					0.93	0.90	0.94	0.85	0.80	0.81	0.81	0.69	0.75
3 3/4					0.96	0.95	0.97	0.87	0.83	0.84	0.83	0.72	0.78
4					1.00	1.00	1.00	0.90	0.87	0.87	0.84	0.76	0.80
4 1/4								0.92	0.90	0.91	0.86	0.79	0.83
4 1/2								0.95	0.93	0.94	0.88	0.82	0.85
4 3/4								0.97	0.97	0.97	0.90	0.85	0.88
5								1.00	1.00	1.00	0.92	0.88	0.90
5 1/4											0.94	0.91	0.93
5 1/2											0.96	0.94	0.95
5 3/4											0.98	0.97	0.98
6		1.00									1.00	1.00	1.00

See notes below.

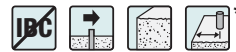

Edge Distance Shear (f_c)

Edge Dist. c_{act} (in.)	Dia.	3/8			1/2			5/8			3/4		
	E	1 1/2	2 3/4	3 3/4	2 3/4	3 3/8	5 3/4	2 3/4	4 1/8	5 3/4	2 3/4	4 3/8	5 3/4
	c_{cr}	6	4 1/2	4 1/2	6	6	6	7 1/2	7 1/2	7 1/2	9	9	9
	c_{min}	6	1 3/4	1 3/4	1 3/4	1 3/4	1 3/4	1 3/4	1 3/4	1 3/4	1 3/4	1 3/4	1 3/4
f_{cmin}	1.00	0.25	0.24	0.25	0.20	0.17	0.19	0.16	0.19	0.19	0.19	0.14	0.13
1 3/4			0.25	0.24	0.25	0.20	0.17	0.19	0.16	0.19	0.19	0.14	0.13
2			0.32	0.31	0.29	0.25	0.22	0.23	0.20	0.23	0.22	0.17	0.16
2 1/2			0.45	0.45	0.38	0.34	0.32	0.30	0.27	0.30	0.27	0.23	0.22
3			0.59	0.59	0.47	0.44	0.41	0.37	0.34	0.37	0.33	0.29	0.28
3 1/2			0.73	0.72	0.56	0.53	0.51	0.44	0.42	0.44	0.39	0.35	0.34
4			0.86	0.86	0.65	0.62	0.61	0.51	0.49	0.51	0.44	0.41	0.40
4 1/2			1.00	1.00	0.74	0.72	0.71	0.58	0.56	0.58	0.50	0.47	0.46
5					0.82	0.81	0.80	0.65	0.63	0.65	0.55	0.53	0.52
5 1/2					0.91	0.91	0.90	0.72	0.71	0.72	0.61	0.58	0.58
6		1.00			1.00	1.00	1.00	0.79	0.78	0.79	0.66	0.64	0.64
6 1/2								0.86	0.85	0.86	0.72	0.70	0.70
7								0.93	0.93	0.93	0.78	0.76	0.76
7 1/2								1.00	1.00	1.00	0.83	0.82	0.82
8											0.89	0.88	0.88
8 1/2											0.94	0.94	0.94
9											1.00	1.00	1.00

The tabled adjustment values (f_c) have been calculated using the following information:

1. E = Embedment depth (inches).
2. c_{act} = actual edge distance at which anchor is installed (inches).
3. c_{cr} = critical edge distance for 100% load (inches).
4. c_{min} = minimum edge distance for reduced load (inches).
5. f_c = percent of allowable load at actual edge distance.
6. $f_{c_{cr}}$ = percentage of allowable load at critical edge distance. $f_{c_{cr}}$ is always = 1.00.
7. $f_{c_{min}}$ = percent of allowable load at minimum edge distance.
8. $f_c = f_{c_{min}} + [(1 - f_{c_{min}}) (c_{act} - c_{min}) / (c_{cr} - c_{min})]$.

* See page 12 for an explanation of the load table icons.

Titen HD® Design Information — Concrete

Load Adjustment Factors for Titen HD® Anchors in Normal-Weight Concrete: Edge Distance, Tension and Shear Loads

How to use these charts:

1. The following tables are for reduced edge distance.
2. Locate the anchor size to be used for either a tension and/or a shear load application.
3. Locate the anchor embedment (E) used for either a tension and/or a shear load application.
4. Locate the edge distance (s_{act}) at which the anchor is to be installed.
5. The load adjustment factor (f_s) is the intersection of the row and column.
6. Multiply the allowable load by the applicable load adjustment factor(s).
7. Reduction factors for multiple edges are multiplied together.

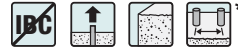

Spacing Tension (f_s)

s_{act} (in)	Dia.	$\frac{3}{8}$			$\frac{1}{2}$			$\frac{5}{8}$			$\frac{3}{4}$		
	E	1½	2¼	3¾	2¼	3½	5¼	2¼	4½	5¼	2¼	4½	5¼
	s_{cr}	4	6	6	8	8	8	10	10	10	12	12	12
	s_{min}	4	1½	1½	2	2	2	2½	2½	2½	3	3	3
	f_{smin}	1.00	0.66	0.56	0.72	0.63	0.76	0.79	0.69	0.73	0.80	0.70	0.72
1													
1½			0.66	0.56									
2			0.70	0.61	0.72	0.63	0.76						
2½			0.74	0.66	0.74	0.66	0.78	0.79	0.69	0.73			
3			0.77	0.71	0.77	0.69	0.80	0.80	0.71	0.75	0.80	0.70	0.72
4		1.00	0.85	0.80	0.81	0.75	0.84	0.83	0.75	0.78	0.82	0.73	0.75
5			0.92	0.90	0.86	0.82	0.88	0.86	0.79	0.82	0.84	0.77	0.78
6			1.00	1.00	0.91	0.88	0.92	0.89	0.83	0.86	0.87	0.80	0.81
7					0.95	0.94	0.96	0.92	0.88	0.89	0.89	0.83	0.84
8					1.00	1.00	1.00	0.94	0.92	0.93	0.91	0.87	0.88
9								0.97	0.96	0.96	0.93	0.90	0.91
10								1.00	1.00	1.00	0.96	0.93	0.94
11											0.98	0.97	0.97
12											1.00	1.00	1.00

See notes below



Spacing Shear (f_s)

s_{act} (in)	Dia.	$\frac{3}{8}$			$\frac{1}{2}$			$\frac{5}{8}$			$\frac{3}{4}$		
	E	1½	2¼	3¾	2¼	3½	5¼	2¼	4½	5¼	2¼	4½	5¼
	s_{cr}	4	0	0	0	0	0	0	0	0	0	0	0
	s_{min}	4	0	0	0	0	0	0	0	0	0	0	0
	f_{smin}	1.00	0.77	0.77	0.77	0.77	0.77	0.77	0.77	0.77	0.77	0.77	0.77
1													
1½			0.77	0.77	0.88								
2			0.80	0.80	0.77	0.77	0.77						
2½			0.82	0.82	0.79	0.79	0.79	0.77	0.77	0.77			
3			0.85	0.85	0.81	0.81	0.81	0.79	0.79	0.79	0.77	0.77	0.77
4		1.00	0.90	0.90	0.85	0.85	0.85	0.82	0.82	0.82	0.80	0.80	0.80
5			0.95	0.95	0.89	0.89	0.89	0.85	0.85	0.85	0.82	0.82	0.82
6			1.00	1.00	0.92	0.92	0.92	0.88	0.88	0.88	0.85	0.85	0.85
7					0.96	0.96	0.96	0.91	0.91	0.91	0.87	0.87	0.87
8					1.00	1.00	1.00	0.94	0.94	0.94	0.90	0.90	0.90
9								0.97	0.97	0.97	0.92	0.92	0.92
10								1.00	1.00	1.00	0.95	0.95	0.95
11											0.97	0.97	0.97
12											1.00	1.00	1.00

The tabled adjustment values (f_s) have been calculated using the following information:

1. E = Embedment depth (inches).
2. s_{act} = actual spacing distance at which anchors are installed (inches).
3. s_{cr} = critical spacing distance for 100% load (inches).
4. s_{min} = minimum spacing distance for reduced load (inches).
5. f_s = adjustment factor for allowable load at actual spacing distance.
6. $f_{s_{cr}}$ = adjustment factor for allowable load at critical spacing distance. $f_{s_{cr}}$ is always = 1.00.
7. $f_{s_{min}}$ = adjustment factor for allowable load at minimum spacing distance.
8. $f_s = f_{s_{min}} + [(1 - f_{s_{min}}) (s_{act} - s_{min}) / (s_{cr} - s_{min})]$.

* See page 12 for an explanation of the load table icons.

Titen HD® Design Information — Masonry

Load-Adjustment Factors for Titen HD® Anchors in Face-of-Wall Installation in 8" Grout-Filled CMU: Edge Distance and Spacing, Tension and Shear Loads

How to use these charts:

- The following tables are for reduced edge distance and spacing.
- Locate the anchor size to be used for either a tension and/or shear load application.
- Locate the embedment (E) at which the anchor is to be installed.
- Locate the edge distance (C_{act}) or spacing (S_{act}) at which the anchor is to be installed.
- The load adjustment factor (f_c or f_s) is the intersection of the row and column.
- Multiply the allowable load by the applicable load adjustment factor.
- Reduction factors for multiple edges or spacings are multiplied together.

Edge or End Distance Tension (f_c)

C_{act} (in.)	Dia.	3F8	½	5F8	3F4
	E	4½	3½	4½	4½
	C_{cr}	12	12	12	12
	C_{min}	4	4	4	4
	f_{cmin}	1.00	1.00	0.83	0.66
4		1.00	1.00	0.83	0.66
6		1.00	1.00	0.87	0.75
8		1.00	1.00	0.92	0.83
10		1.00	1.00	0.96	0.92
12		1.00	1.00	1.00	1.00

See notes below

Edge or End Distance Shear (f_c) Shear Load Perpendicular to Edge or End (Directed Towards Edge or End)

C_{act} (in.)	Dia.	¾	½	5/8	¾
	E	2¾	3½	4½	5½
	C_{cr}	12	12	12	12
	C_{min}	4	4	4	4
	f_{cmin}	0.58	0.38	0.30	0.21
4		0.58	0.38	0.30	0.21
6		0.69	0.54	0.48	0.41
8		0.79	0.69	0.65	0.61
10		0.90	0.85	0.83	0.80
12		1.00	1.00	1.00	1.00

- E = Embedment depth (inches).
- C_{act} = actual end or edge distance at which anchor is installed (inches).
- C_{cr} = critical end or edge distance for 100% load (inches).
- C_{min} = minimum end or edge distance for reduced load (inches).
- f_c = adjustment factor for allowable load at actual end or edge distance.
- f_{ccr} = adjustment factor for allowable load at critical end or edge distance.
 f_{ccr} is always = 1.00.
- f_{cmin} = adjustment factor for allowable load at minimum end or edge distance.
- $f_c = f_{cmin} + [(1 - f_{cmin})(C_{act} - C_{min}) / (C_{cr} - C_{min})]$.

Spacing Tension (f_s)

S_{act} (in.)	Dia.	¾	½	5/8	¾
	E	2¾	3½	4½	5½
	S_{cr}	6	8	10	12
	S_{min}	3	4	5	6
	f_{smin}	0.87	0.69	0.59	0.50
3		0.87			
4		0.91	0.69		
5		0.96	0.77	0.59	
6		1.00	0.85	0.67	0.50
8			1.00	0.84	0.67
10				1.00	0.83
12					1.00

- E = Embedment depth (inches).
- S_{act} = actual spacing distance at which anchors are installed (inches).
- S_{cr} = critical spacing distance for 100% load (inches).
- S_{min} = minimum spacing distance for reduced load (inches).
- f_s = adjustment factor for allowable load at actual spacing distance.
- f_{scr} = adjustment factor for allowable load at critical spacing distance. f_{scr} is always = 1.00.
- f_{smin} = adjustment factor for allowable load at minimum spacing distance.
- $f_s = f_{smin} + [(1 - f_{smin})(S_{act} - S_{min}) / (S_{cr} - S_{min})]$.

* See page 12 for an explanation of the load table icons.

Edge and End Distance Shear (f_c) Shear Load Parallel to Edge or End

C_{act} (in.)	Dia.	¾	½	5/8	¾
	E	2¾	3½	4½	4½
	C_{cr}	12	12	12	12
	C_{min}	4	4	4	4
	f_{cmin}	0.77	0.48	0.46	0.44
4		0.77	0.48	0.46	0.44
6		0.83	0.61	0.60	0.58
8		0.89	0.74	0.73	0.72
10		0.94	0.87	0.87	0.86
12		1.00	1.00	1.00	1.00

See notes below

Edge or End Distance Shear (f_c) Shear Load Perpendicular to Edge or End (Directed Away From Edge or End)

C_{act} (in.)	Dia.	¾	½	5/8	¾
	E	2¾	3½	4½	5½
	C_{cr}	12	12	12	12
	C_{min}	4	4	4	4
	f_{cmin}	0.89	0.79	0.58	0.38
4		0.89	0.79	0.58	0.38
6		0.92	0.84	0.69	0.54
8		0.95	0.90	0.79	0.69
10		0.97	0.95	0.90	0.85
12		1.00	1.00	1.00	1.00

Spacing Shear (f_s)

S_{act} (in.)	Dia.	¾	½	5/8	¾
	E	2¾	3½	4½	5½
	S_{cr}	6	8	10	12
	S_{min}	3	4	5	6
	f_{smin}	0.62	0.62	0.62	0.62
3		0.62			
4		0.75	0.62		
5		0.87	0.72	0.62	
6		1.00	0.81	0.70	0.62
8			1.00	0.85	0.75
10				1.00	0.87
12					1.00

Titen HD® Rod Coupler

The Titen HD® Rod Coupler is designed to be used in conjunction with a single or multi-story rod tie-down system. This anchor provides a fast and simple way to attach threaded rod to a concrete stem wall or thickened slab footing. Unlike adhesive anchors, the installation requires no special tools, cure time or secondary setting process; just drill a hole and drive the anchor.

Features

- The serrated cutting teeth and patented thread design enable the Titen HD Rod Coupler to be installed quickly and easily. Less installation time translates to lower installed cost
- The specialized heat treating process creates tip hardness to facilitate cutting while the body remain ductile
- No special setting tools are required. The Titen HD Rod Coupler installs with regular or hammer drill, ANSI size bits and standard sockets
- Compatible with threaded rods in $\frac{3}{8}$ " and $\frac{1}{2}$ " diameters

Material: Carbon steel

Coating: Zinc plated

Installation



Caution: Oversized holes in the base material will reduce or eliminate the mechanical interlock of the threads with base material and will reduce the anchor's load capacity. Use a Titen HD® Rod Coupler one time only. Installing the anchor multiple times may result in excessive thread wear and reduce load capacity.

1. Drill a hole using the specified diameter carbide bit into the base material to a depth of at least $\frac{1}{2}$ " deeper than the required embedment.
2. Blow the hole clean of dust and debris using compressed air. Overhead application need not be blown clean.
3. Tighten the anchor with appropriate size socket until the head sits flush against base material.



Titen HD® Rod Coupler
U.S. Patent
5,674,035 & 6,623,228

Installation Sequence:

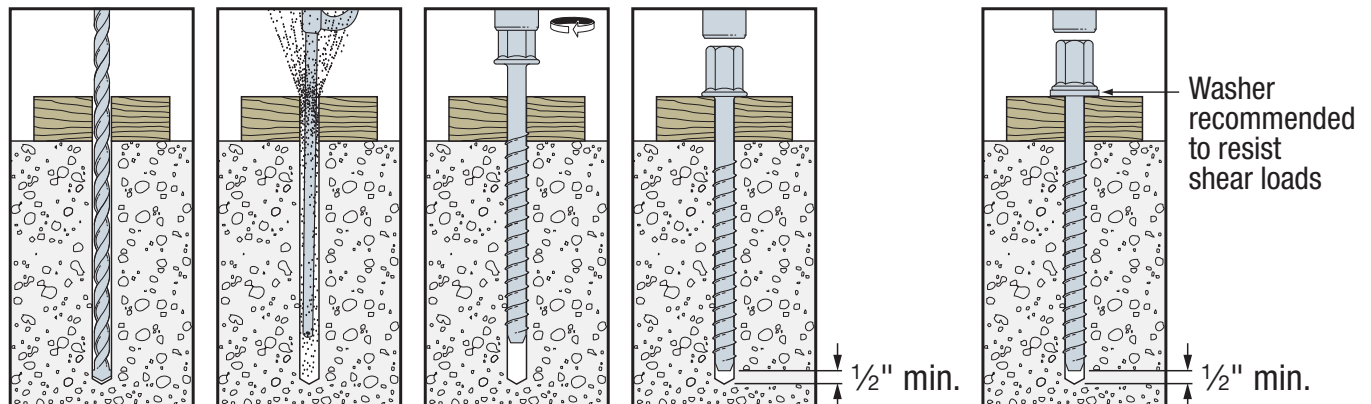

Titen HD® Rod Coupler

Titen HD® Rod Coupler Product Data

Size (in)	Model No.	Accepts Rod Dia. (in.)	Drill Bit Dia. (in)	Wrench Size (in)	Quantity	
					Box	Carton
3/8 x 6 3/4	THD37634RC	3/8	3/8	9/16	50	100
1/2 x 9 3/4	THD50934RC	1/2	1/2	3/4	20	40

Titen HD® Rod Coupler Allowable Tension Loads in Normal-Weight Concrete Stemwall



Size in. (mm)	Drill Bit Dia. in.	Embed. Depth in. (mm)	Stemwall Width in. (mm)	Minimum Edge Dist. in. (mm)	Minimum End Dist. in. (mm)	Minimum Spacing Dist. in. (mm)	Tension Load Based on Concrete Strength		Tension Load Based on Connected Rod Strength
							$f'_c \geq 2500$ psi (17.2 MPa) Concrete		A307 (SAE 1018)
							Ultimate lb. (kN)	Allowable lb. (kN)	Allowable lb. (kN)
3/8 (9.5)	3/8	5 (127)	8 (203)	1 3/4 (45)	10 (254)	20 (508)	8,900 (39.6)	2,225 (9.9)	2,105 (9.4)
1/2 (12.7)	1/2	8 (203)	8 (203)	1 3/4 (45)	16 (406)	32 (813)	15,540 (69.1)	3,885 (17.3)	3,750 (16.7)

1. Allowable load must be the lesser of the concrete or steel strength.
2. The allowable loads based on concrete strength are based on a factor of safety of 4.0.
3. The allowable load based on steel strength is limited by the strength of the coupler nut supplied with this anchor. Use of higher strength rod will not increase allowable loads.
4. The minimum concrete thickness is 1.5 times the embedment depth.
5. Tension and shear loads may be combined using the straight-line interaction equation ($n=1$).

Titen HD® Rod Coupler Allowable Shear Loads in Normal-Weight Concrete Stemwall, Load Applied Parallel to Concrete Edge



Size in. (mm)	Drill Bit Dia. in.	Embed. Depth in. (mm)	Stemwall Width in. (mm)	Minimum Edge Dist. in. (mm)	Minimum End Dist. in. (mm)	Minimum Spacing Dist. in. (mm)	Shear Load Based on Conc. Edge Dist.	
							$f'_c \geq 2500$ psi (17.2 MPa) Concrete	
							Ultimate lb. (kN)	Allowable lb. (kN)
1/2 (12.7)	1/2	8 (203)	8 (203)	1 3/4 (45)	16 (406)	32 (813)	6,200 (27.6)	1,550 (6.9)

1. Install with a washer (not supplied with anchor) when used to resist shear loads.
2. The allowable load based on concrete edge distance is based on a factor of safety of 4.0. Steel strength does not control.
3. The minimum concrete thickness is 1.5 times the embedment depth.
4. Tension and shear loads may be combined using the straight-line interaction equation ($n=1$).

* See page 12 for an explanation of the load table icons.

Titen® Concrete and Masonry Screw

Titen® screws are hardened screws for attaching all types of components to concrete and masonry. These fasteners are commonly used in applications such as attaching electrical boxes, light fixtures or window frames into concrete or masonry base materials.

Features

- Available in 3/16" and 1/4" diameter sizes
- Available in hex and Phillips flat-head designs in two colors
- Drill bit included with each box

Material: Carbon steel

Coating: Zinc plated with a baked-on ceramic coating

Codes: Florida FL-2355.1

Installation



Caution: Industry studies show that hardened fasteners can experience performance problems in wet or corrosive environments. Steps must be taken to prevent inadvertent sustained loads above the listed allowable loads. Overtightening and bending moments can initiate cracks detrimental to the hardened screw's performance. Use the Simpson Strong-Tie installation tool kit. It is designed to reduce the potential for overtightening the screw.

Caution: Oversized holes in the base material will reduce or eliminate the mechanical interlock of the threads with the base material and will reduce the anchor's load capacity.

1. Drill a hole in the base material using the appropriate diameter carbide drill bit as specified in the table. Drill the hole to the specified embedment depth plus 1/2" to allow the thread tapping dust to settle and blow it clean using compressed air. Overhead installations need not be blown clean. Alternatively, drill the hole deep enough to accommodate embedment depth and dust from drilling and tapping.
2. Position fixture, insert screw and tighten using drill and installation tool fitted with a hex socket or phillips bit.

Preservative-treated wood applications: suitable for use in non-ammonia formulations of CCA, ACQ-C, ACQ-D, CA-B, BX/DOT and zinc borate. Use in dry, interior environments only.

Use caution not to damage ceramic barrier coating during installation. Recommendations are based on testing and experience at time of publication and may change. Simpson Strong-Tie cannot provide estimates on service life of screws.



Titen®
Hex-Head Screw (H)

Titen®
Phillips Flat-Head
Screw (PF)

Installation Sequence

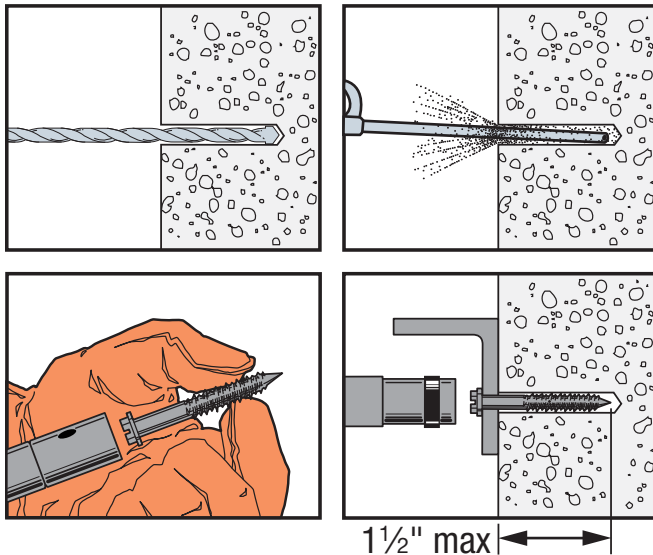

Titen® Phillips head screw
available in white and
standard blue

Titen® Concrete and Masonry Screw

Blue Titen® Product Data (3/16" diameter)

Size (in.)	Model No. ¹	Drill Bit Diameter (in.)	Quantity	
			Box ²	Carton
3/16 x 1 1/4	TTN18114H	5/32	100	1600
3/16 x 1 3/4	TTN18134H			500
3/16 x 2 1/4	TTN18214H			500
3/16 x 2 3/4	TTN18234H			500
3/16 x 3 1/4	TTN18314H			400
3/16 x 3 3/4	TTN18334H			400
3/16 x 4	TTN18400H			400
3/16 x 1 1/4	TTN18114PF	5/32	100	1600
3/16 x 1 3/4	TTN18134PF			500
3/16 x 2 1/4	TTN18214PF			500
3/16 x 2 3/4	TTN18234PF			500
3/16 x 3 1/4	TTN18314PF			400
3/16 x 3 3/4	TTN18334PF			400
3/16 x 4	TTN18400PF			400

1. H Suffix: Hex-Head, PF Suffix: Phillips Flat-Head.

Blue Titen® Product Data (1/4" diameter)

Size (in.)	Model No. ¹	Drill Bit Diameter (in.)	Quantity	
			Box ²	Carton
1/4 x 1 1/4	TTN25114H	3/16	100	1600
1/4 x 1 3/4	TTN25134H			500
1/4 x 2 1/4	TTN25214H			500
1/4 x 2 3/4	TTN25234H			500
1/4 x 3 1/4	TTN25314H			400
1/4 x 3 3/4	TTN25334H			400
1/4 x 4	TTN25400H			400
1/4 x 5	TTN25500H	400		
1/4 x 6	TTN25600H	400		
1/4 x 1 1/4	TTN25114PF	3/16	100	1600
1/4 x 1 3/4	TTN25134PF			500
1/4 x 2 1/4	TTN25214PF			500
1/4 x 2 3/4	TTN25234PF			500
1/4 x 3 1/4	TTN25314PF			400
1/4 x 3 3/4	TTN25334PF			400
1/4 x 4	TTN25400PF			400
1/4 x 5	TTN25500PF	400		
1/4 x 6	TTN25600PF	400		

1. H Suffix: Hex-Head, PF Suffix: Phillips Flat-Head.

White Titen® Product Data (Phillips Flat-Head)

Size (in.)	Model No.	Drill Bit Diameter (in.)	Quantity	
			Box ¹	Carton
3/16 x 1 1/4	TTNW18114PF	5/32	100	1600
3/16 x 1 3/4	TTNW18134PF			500
3/16 x 2 1/4	TTNW18214PF			500
3/16 x 2 3/4	TTNW18234PF			500
3/16 x 3 1/4	TTNW18314PF			400
3/16 x 3 3/4	TTNW18334PF			400
1/4 x 1 1/4	TTNW25114PF			3/16
1/4 x 1 3/4	TTNW25134PF	500		
1/4 x 2 1/4	TTNW25214PF	500		
1/4 x 2 3/4	TTNW25234PF	500		
1/4 x 3 1/4	TTNW25314PF	400		
1/4 x 3 3/4	TTNW25334PF	400		

Titen® Allowable Tension and Shear Loads in Face Shell of Hollow and Grout-Filled CMU

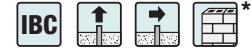

Dia. in. (mm)	Drill Bit Dia. in.	Embed. Depth in. (mm)	Critical Spacing in. (mm)	Critical Edge Dist. in. (mm)	Values for 6" or 8" Lightweight, Medium-Weight or Normal-Weight CMU			
					Tension Load		Shear Load	
					Avg. Ult. lb. (kN)	Allow. lb. (kN)	Avg. Ult. lb. (kN)	Allow. lb. (kN)
3/16 (4.8)	5/32	1 (25.4)	2 1/4 (57.2)	1 1/8 (28.6)	542 (2.4)	110 (0.5)	1,016 (4.5)	205 (0.9)
1/4 (6.4)	3/16	1 (25.4)	3 (76.2)	1 1/2 (38.1)	740 (3.3)	150 (0.7)	1,242 (5.5)	250 (1.1)

1. The tabulated allowable loads are based on a safety factor of 5.0.
2. Maximum anchor embedment is 1 1/2" (38.1 mm).

Titen® Allowable Tension and Shear Loads in Normal-Weight Concrete



Dia. in. (mm)	Drill Bit Dia. in.	Embed. Depth in. (mm)	Critical Spacing in. (mm)	Critical Edge Dist. in. (mm)	Tension Load				Shear Load	
					f'c ≥ 2,000 psi (13.8 MPa) Concrete		f'c ≥ 4,000 psi (27.6 MPa) Concrete		f'c ≥ 2,000 psi (13.8 MPa) Concrete	
					Ultimate lb. (kN)	Allowable lb. (kN)	Ultimate lb. (kN)	Allowable lb. (kN)	Ultimate lb. (kN)	Allowable lb. (kN)
3/16 (4.8)	5/32	1 (25.4)	2 1/4 (57.2)	1 1/8 (28.6)	500 (2.2)	125 (0.6)	640 (2.8)	160 (0.7)	1,020 (4.5)	255 (1.1)
3/16 (4.8)	5/32	1 1/2 (38.1)	2 1/4 (57.2)	1 1/8 (28.6)	1,220 (5.4)	305 (1.4)	1,850 (8.2)	460 (2.0)	1,670 (7.4)	400 (1.8)
1/4 (6.4)	3/16	1 (25.4)	3 (76.2)	1 1/2 (38.1)	580 (2.6)	145 (0.6)	726 (3.2)	180 (0.8)	900 (4.0)	225 (1.0)
1/4 (6.4)	3/16	1 1/2 (38.1)	3 (76.2)	1 1/2 (38.1)	1,460 (6.5)	365 (1.6)	2,006 (8.9)	500 (2.2)	1,600 (7.1)	400 (1.8)

1. Maximum anchor embedment is 1 1/2" (38.1 mm).
2. Concrete must be minimum 1.5 x embedment.

* See page 12 for an explanation of the load table icons.

Titen® Stainless Steel Concrete and Masonry Screw

Stainless Steel Titen® screws are ideal for attaching various types of components to concrete and masonry, such as fastening electrical boxes or light fixtures. They offer the versatility of our standard Titen screws with enhanced corrosion protection. Available in hex and Phillips flat head.

Features

- Suitable for concrete, brick, grout-filled CMU and hollow-block applications
- Suitable for some preservative-treated wood applications
- Acceptable for exterior use
- Titen drill bits included in each box
- Available in lengths from 1 1/4"-4"

Material: Type 410 stainless steel

Coating: Zinc plated with a protective overcoat

Installation

Caution: Industry studies show that hardened fasteners can experience performance problems in wet or corrosive environments. Steps must be taken to prevent inadvertent sustained loads above the listed allowable loads. Overtightening and bending moments can initiate cracks detrimental to the hardened screw's performance. Use the Simpson Strong-Tie Titen installation tool kit as it has a bit that is designed to reduce the potential for overtightening the screw.

Caution: Oversized holes in the base material will reduce or eliminate the mechanical interlock of the threads with the base material and will reduce the anchor's load capacity.

1. Drill a hole in the base material using the appropriate diameter carbide drill bit as specified in the table. Drill the hole to the specified embedment depth plus 1/2" to allow the thread tapping dust to settle and blow it clean using compressed air. Overhead installations need not be blown clean. Alternatively, drill the hole deep enough to accommodate embedment depth and dust from drilling and tapping.
2. Position fixture, insert screw and tighten using drill and Titen screw installation tool fitted with a hex socket or phillips bit.

Preservative-treated wood applications: suitable for use in non-ammonia formulations of CCA, ACQ-C, ACQ-D, CA-B, SBX/DOT and zinc borate. Acceptable for use in exterior environments. Use caution not to damage coating during installation. The 410 stainless-steel Titen with top coat provides "medium" corrosion protection. Recommendations are based on testing and experience at time of publication and may change. Simpson Strong-Tie cannot provide estimates on service life of screws.



Titen®
Stainless-Steel
Phillips Flat Head Screw
(PFSS)



Titen®
Stainless-Steel
Hex-Head Screw
(HSS)

Mechanical Anchors

Installation Sequence

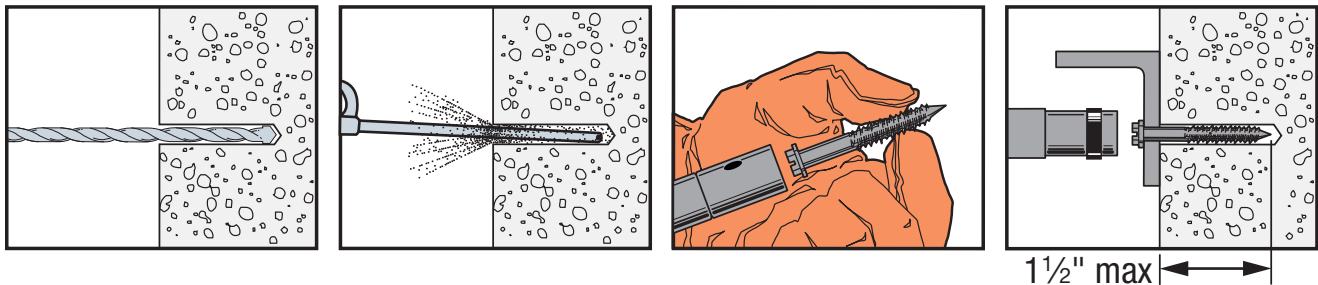

Titen® Stainless Steel Concrete and Masonry Screw

Stainless-Steel Titen® Product Data

Size (in.)	Head Style	Model No.	Drill Bit Dia. (in.)	Quantity	
				Box	Carton
1/4 x 1 1/4	Hex-Head	TTN25114HSS	3/16	100	1600
1/4 x 1 3/4		TTN25134HSS		100	500
1/4 x 2 1/4		TTN25214HSS		100	500
1/4 x 2 3/4		TTN25234HSS		100	500
1/4 x 3 1/4		TTN25314HSS		100	400
1/4 x 3 3/4		TTN25334HSS		100	400
1/4 x 4		TTN25400HSS		100	400
1/4 x 1 1/4	Phillips Flat-Head	TTN25114PFSS	3/16	100	1600
1/4 x 1 3/4		TTN25134PFSS		100	500
1/4 x 2 1/4		TTN25214PFSS		100	500
1/4 x 2 3/4		TTN25234PFSS		100	500
1/4 x 3 1/4		TTN25314PFSS		100	400
1/4 x 3 3/4		TTN25334PFSS		100	400
1/4 x 4		TTN25400PFSS		100	400

One drill bit is included in each box.

Stainless-Steel Titen® Allowable Tension and Shear Loads in Normal-Weight Concrete

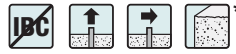

Dia. in. (mm)	Drill Bit Dia. in.	Embed. Depth in. (mm)	Critical Spacing in. (mm)	Critical Edge Dist. in. (mm)	Tension Load				Shear Load	
					f'c ≥ 2,000 psi (13.8 MPa) Concrete		f'c ≥ 4,000 psi (27.6 MPa) Concrete		f'c ≥ 2,000 psi (13.8 MPa) Concrete	
					Ultimate lb. (kN)	Allow. lb. (kN)	Ultimate lb. (kN)	Allow. lb. (kN)	Ultimate lb. (kN)	Allow. lb. (kN)
1/4 (6.4)	3/16	1 (25.4)	3 (76.2)	1 1/2 (38.1)	600 (2.7)	150 (0.7)	935 (4.2)	235 (1.0)	760 (3.4)	190 (0.8)
1/4 (6.4)	3/16	1 1/2 (38.1)	3 (76.2)	1 1/2 (38.1)	1,040 (4.6)	260 (1.2)	1,760 (7.8)	440 (2.0)	810 (3.6)	200 (0.9)

1. Maximum anchor embedment is 1 1/2" (38.1 mm).
2. Minimum concrete thickness is 1.5 x embedment.

Stainless-Steel Titen® Allowable Tension and Shear Loads in Face Shell of Hollow and Grout-Filled CMU



Dia. in. (mm)	Drill Bit Dia. in.	Embed. Depth in. (mm)	Critical Spacing in. (mm)	Critical Edge Dist. in. (mm)	Values for 6" or 8" Lightweight, Medium-Weight or Normal-Weight CMU			
					Tension Load		Shear Load	
					Ultimate lb. (kN)	Allow. lb. (kN)	Ultimate lb. (kN)	Allow. lb. (kN)
1/4 (6.4)	3/16	1 (25.4)	4 (101.6)	1 1/2 (38.1)	550 (2.4)	110 (0.5)	495 (2.2)	100 (0.4)

1. The tabulated allowable loads are based on a safety factor of 5.0.
2. Maximum anchor embedment is 1 1/2" (38.1 mm).

* See page 12 for an explanation of the load table icons.

Titen® Screw – Installation Accessories

Titen® Screw – Installation Tool

The Simpson Strong-Tie® Titen® screw installation kit makes installation of Titen screws quick and easy. Accessories are compatible with a standard three-jaw style chuck, and the sockets have been designed to prevent over-torquing, which can lead to fastener failure. Comes packaged in a rugged plastic box ideal for storage of the installation kit and Titen screws.

Eight-piece kit includes:

- Drill bit holder
- Phillips bit socket
- 5/8" sleeve
- #2 and #3 Phillips bits
- 1/4" and 5/16" hex sockets
- Allen wrench

Titen® Installation Tool

Model No.	Quantity	
	Box	Carton
TTNT01	1	24



Titen®
Screw Installation Kit
(Model TTNT01)



Special hex adapter (included with the Titen Screw Installation Kit) allows the Titen Installation Tool to slide over the bit and lock in, ready to drive screws.

Titen® Screw – Drill Bits

The same bits that come included with boxes of Titen screws are also available separately. They work with the Titen Installation Tool as well as drills with a standard three-jaw style chuck.

Titen® Drill Bits

Size (in.)	Model No.	Use With		Quantity	
		Screw	Length	Box	Carton
5/32 x 3 1/2	MDB15312	3/16" dia.	To 1 3/4	12	48
5/32 x 4 1/2	MDB15412		To 3 1/4		
5/32 x 5 1/2	MDB15512		To 4		
3/16 x 3 1/2	MDB18312	1/4" dia.	To 1 3/4	12	48
3/16 x 4 1/2	MDB18412		To 3 1/4		
3/16 x 5 1/2	MDB18512		To 4		



Titen®
Screw Drill Bit

Titen® Screw – SDS-Plus Drill Bit/Driver

This SDS-Plus shank bit works with the Titen Installation Tool to allow pre-drilling and installation of Titen screws using a rotohammer. Rotohammer must be in rotation-only mode before driving screws.

Titen® Drill Bit/Driver Product Data

Size (in.)	Model No.	For Screw Dia. (in.)	Drilling Depth (in.)	Overall Length (in.)
5/32 x 5	MDBP15500H	3/16	2 1/4	5
5/32 x 6	MDBP15600H		3 1/4	6
5/32 x 7	MDBP15700H		4 1/4	7
3/16 x 5	MDBP18500H	1/4	2 1/4	5
3/16 x 6	MDBP18600H		3 1/4	6
3/16 x 7	MDBP18700H		4 1/4	7



Titen®
Screw Drill Bit / Driver

Titen drivers are sold individually.

Titen HD® Threaded Rod Hanger

The Titen HD® threaded rod hanger is a high-strength screw anchor designed to suspend threaded rod from concrete slabs and beams or concrete over metal in order to hang pipes, cable trays and HVAC equipment. The anchor offers low installation torque with no secondary setting, and has been tested to offer industry-leading performance in cracked and uncracked concrete – even in seismic loading conditions.



Features

- Thread design undercuts to efficiently transfer the load to the base material
- Serrated cutting teeth and patented thread design enable quick and easy installation
- Specialized heat-treating process creates tip hardness to facilitate cutting while the anchor body remains ductile
- Designed to install using a rotary hammer or hammer drill with standard ANSI drill bits – no special tools required
- Installs with standard-sized sockets
- The THD50234RH and THD37212RH are code listed for cracked and uncracked concrete applications under the 2012 and 2009 IBC/IRC, per ICC-ES ESR-2713

Codes: ICC-ES ESR-2713 (THD37212RH and THD50234RH); City of L.A. RR25741; Florida FL-15730.6; Factory Mutual 3031136 (THD50234RH and THD37218RH) and 3035761 (THD37212RH)

Material: Carbon steel

Coating: Zinc plated

Installation

- Caution:** Oversized holes in the base material will reduce or eliminate the mechanical interlock of the threads with base material and will reduce the anchor's load capacity.
- Caution:** Use a Titen HD® Rod Hanger one time only. Installing the anchor multiple times may result in excessive thread wear and reduce load capacity.
1. Drill a hole using the specified diameter carbide bit into the base material to a depth of at least ½" deeper than the required embedment.
 2. Blow the hole clean of dust and debris using compressed air.
 3. **IMPORTANT:** Install with an applied torque of 15 ft-lbs for the THD25112RH and THD37218RH rod hangers using a torque wrench, driver drill, hammer drill or cordless ¼" impact driver with a maximum permitted torque rating of 100 ft-lb.



THD50234RH
(¾" dia. shank)



THD37212RH
(¾" dia. shank)



THD37218RH
(¼" dia. shank)



THD25112RH
(¼" dia. shank)

U.S. Patent
5,674,035 &
6,623,228

Installation Sequence

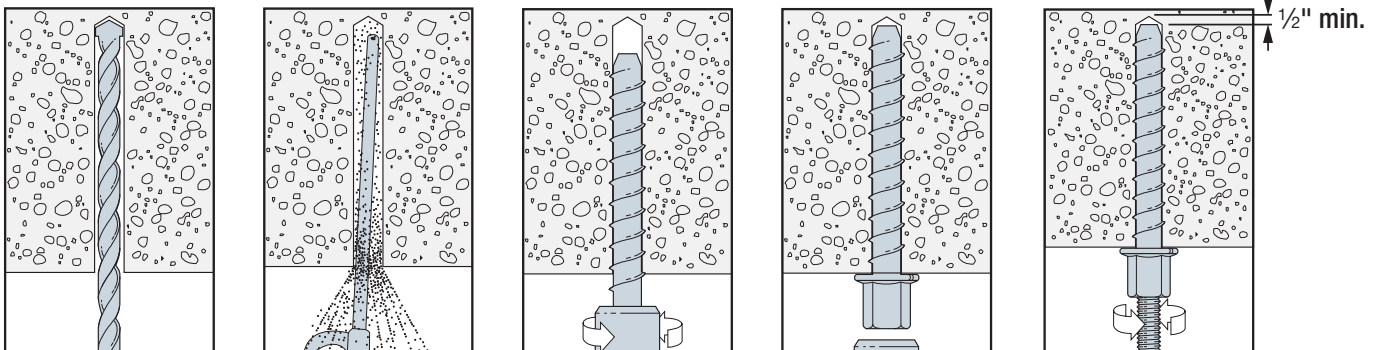

Titen HD® Rod Hanger Design Information — Concrete

Titen HD® Threaded Rod Hanger Product Data

Size (in.)	Model No.	Accepts Rod Dia. (in.)	Drill Bit Dia. (in.)	Wrench Size (in.)	Min. Embed. (in.)	Quantity	
						Box	Carton
¼ x 1½	THD25112RH	¼	¼	¾	1½	100	500
⅜ x 2⅞	THD37218RH	⅜	¼	½	2⅞	50	250
⅜ x 2½	THD37212RH	⅜	⅜	½	2½	50	200
½ x 2¾	THD50234RH	½	⅜	11/16	2¾	50	100

Titen HD® Threaded Rod Hanger Installation Information and Additional Data¹

Characteristic	Symbol	Units	Model Number	
			THD37212RH	THD50234RH
Installation Information				
Rod Hanger Diameter	d_o	in.	¾	½
Drill Bit Diameter	d_{bit}	in.	¾	¾
Maximum Installation Torque ²	$T_{inst,max}$	ft.-lb.	50	50
Maximum Impact Wrench Torque Rating ³	$T_{impact,max}$	ft.-lb.	150	150
Minimum Hole Depth	h_{hole}	in.	3	3¼
Embedment Depth	h_{nom}	in.	2½	2¾
Effective Embedment Depth	h_{ef}	in.	1.77	1.77
Critical Edge Distance	c_{ac}	in.	21/16	21/16
Minimum Edge Distance	c_{min}	in.	1¾	
Minimum Spacing	s_{min}	in.	3	
Minimum Concrete Thickness	h_{min}	in.	4¼	4¼
Anchor Data				
Yield Strength	f_{ya}	psi	97,000	
Tensile Strength	f_{uta}	psi	110,000	
Minimum Tensile and Shear Stress Area	A_{se}	in. ²	0.099	0.099
Axial Stiffness in Service Load Range – Uncracked Concrete	β_{uncr}	lb./in.	715,000	
Axial Stiffness in Service Load Range – Cracked Concrete	β_{cr}	lb./in.	345,000	

1. The information presented in this table is to be used in conjunction with the design criteria of ACI 318 Appendix D.

2. $T_{inst,max}$ is the maximum permitted installation torque for installations using a torque wrench.

3. $T_{impact,max}$ is the maximum permitted torque rating for impact wrenches.

Titen HD® Rod Hanger Design Information — Concrete

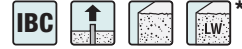
Titen HD® Threaded Rod Hanger Tension Strength Design Data
for Installations in Concrete^{1,6}

Characteristic	Symbol	Units	Model Number	
			THD37212RH	THD50234RH
Anchor Category	1, 2 or 3	—	1	
Embedment Depth	h_{nom}	in.	2½	2¾
Steel Strength in Tension (ACI 318 Section D.5.1)				
Tension Resistance of Steel	N_{sa}	lb.	10,890	10,890
Strength Reduction Factor – Steel Failure ²	ϕ_{sa}	—	0.65	
Concrete Breakout Strength in Tension (ACI 318 Section D.5.2)⁶				
Effective Embedment Depth	h_{ef}	in.	1.77	1.77
Critical Edge Distance	c_{ac}	in.	2 ¹ / ₁₆	2 ¹ / ₁₆
Effectiveness Factor – Uncracked Concrete	k_{uncr}	—	24	
Effectiveness Factor – Cracked Concrete	k_{cr}	—	17	
Modification Factor	$\psi_{c,N}$	—	1.0	
Strength Reduction Factor – Concrete Breakout Failure ⁵	ϕ_{cb}	—	0.65	
Pullout Strength in Tension (ACI 318 Section D.5.3)⁶				
Pullout Resistance – Uncracked Concrete ($f'_c = 2,500$ psi)	$N_{p,uncr}$	lb.	2,025 ³	2,025 ³
Pullout Resistance – Cracked Concrete ($f'_c = 2,500$ psi)	$N_{p,cr}$	lb.	1,235 ³	1,235 ³
Strength Reduction Factor – Pullout Failure ⁴	ϕ_p	—	0.65	
Tension Strength for Seismic Applications (ACI 318 Section D.3.3)⁶				
Nominal Pullout Strength for Seismic Loads ($f'_c = 2,500$ psi)	$N_{p,eq}$	lb.	1,235 ³	1,235 ³
Strength Reduction Factor – Pullout Failure ⁴	ϕ_{eq}	—	0.65	

- The information presented in this table is to be used in conjunction with the design criteria of ACI 318 Appendix D, except as modified below.
- The value of ϕ applies when the load combinations of ACI 318 Section 9.2 are used. If the load combinations of ACI 318 Appendix C are used, refer to Section D.4.4 to determine the appropriate value of ϕ . Anchors are considered brittle steel elements.
- Adjust the characteristic pullout resistance for other concrete compressive strengths by multiplying the tabular value by $(f'_{c,specified}/2,500)^{0.5}$.
- The value of ϕ applies when both the load combinations of ACI 318 Section 9.2 are used and the requirements of Section D.4.3(c) for Condition B are met. If the load combinations of ACI 318 Appendix C are used, refer to Section D.4.4 to determine the appropriate value of ϕ .

- The value of ϕ applies when both the load combinations of ACI 318 Section 9.2 are used and the requirements of Section D.4.3(c) for Condition B are met. If the load combinations of ACI 318 Section 9.2 are used and the requirements of Section D.4.3(c) for Condition A are met, refer to Section D.4.3 to determine the appropriate value of ϕ . If the load combinations of ACI 318 Appendix C are used, refer to Section D.4.4 to determine the appropriate value of ϕ .
- For sand-lightweight concrete, the modification factor for concrete breakout strength must be taken as 0.6. Additionally, the pullout strength $N_{p,uncr}$, $N_{p,cr}$ and $N_{p,eq}$ must be multiplied by 0.6, as applicable.
- For sand-lightweight concrete, in lieu of ACI 318 Section D.3.6, modify the value of concrete breakout strength, $N_{p,cr}$, $N_{p,uncr}$ and $N_{p,eq}$ by 0.6. All-lightweight concrete is beyond the scope of this table.

* See page 12 for an explanation of the load table icons.

Titen HD® Rod Hanger Design Information – Concrete

Titen HD® Threaded Rod Hanger Tension Strength Design Data for Installations in the Lower and Upper Flute of Normal-Weight or Sand-Lightweight Concrete Through Metal Deck^{1,2,5,6}



Characteristic	Symbol	Units	Model No.	
			THD37212RH	THD50234RH
Minimum Hole Depth	h_{hole}	in.	3	3¼
Embedment Depth	h_{nom}	in.	2½	2¾
Effective Embedment Depth	h_{ef}	in.	1.77	1.77
Pullout Resistance – Cracked Concrete ^{2,3,4}	$N_{p,deck,cr}$	lbf.	870	870
Pullout Resistance – Uncracked Concrete ^{2,3,4}	$N_{p,deck,uncr}$	lbf.	1,430	1,430

- The information presented in this table is to be used in conjunction with the design criteria of ACI 318 Appendix D, except as modified below.
- Concrete compressive strength shall be 3,000 psi minimum. The characteristic pullout resistance for greater compressive strengths shall be increased by multiplying the tabular value by $(f'_c / 3,000 \text{ psi})^{0.5}$.
- For anchors installed in the soffit of sand-lightweight or normal-weight concrete over metal deck floor and roof assemblies, as shown in Figure 1, calculation of the concrete breakout strength may be omitted.
- In accordance with ACI 318 Section D.5.3.2, the nominal pullout strength in cracked concrete for anchors installed in the soffit of sand-lightweight or normal-weight-concrete-over-metal-deck floor and roof assemblies $N_{p,deck,cr}$ shall be substituted for $N_{p,cr}$. Where analysis indicates no cracking at service loads, the normal pullout strength in uncracked concrete $N_{p,deck,uncr}$ shall be substituted for $N_{p,uncr}$.
- Minimum distance to edge of panel is $2h_{ef}$.
- The minimum anchor spacing along the flute must be the greater of $3h_{ef}$ or 1.5 times the flute width.

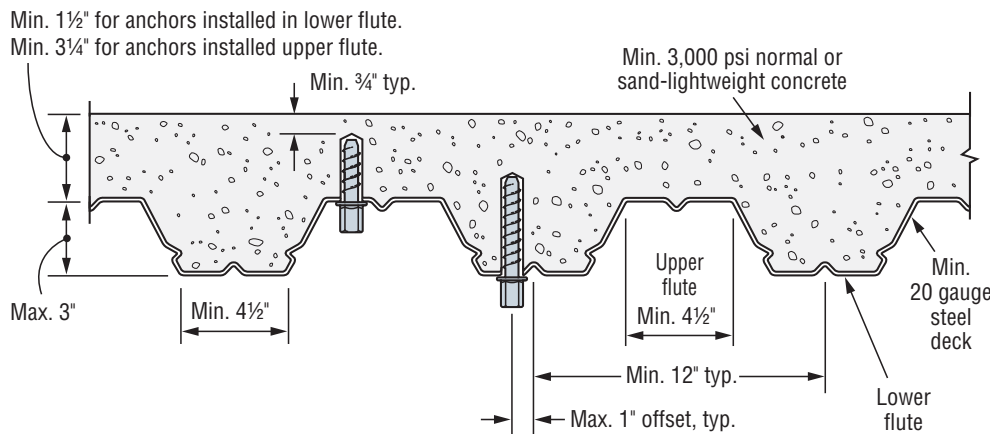

Figure 1. Installation in Concrete Over Metal Deck

Titen HD® Threaded Rod Hanger Allowable Tension Loads in Normal-Weight Concrete



Model Number	Rod Hanger Dia. (in.)	Drill Bit Dia. (in.)	Emb. Depth (in.)	Critical Edge Distance (in.)	Critical Spacing Distance (in.)	Tension Load			
						$f'_c \geq 2,000$ psi Concrete		$f'_c \geq 4,000$ psi Concrete	
						Ultimate (lb.)	Allowable (lb.)	Ultimate (lb.)	Allowable (lb.)
THD25112RH	¼	¼	1½	3	6	1,319	330	2,102	525
THD37218RH	¾	¼	2½	3	6	2,210	555	3,227	805
THD37212RH	¾	¾	2½	3	6	3,650	915	5,275	1,320
THD50234RH	½	¾	2¾	3	6	4,297	1,075	6,204	1,550

- The allowable loads listed are based on a safety factor of 4.0.
- Allowable loads may not be increased for short-term loading due to wind or seismic forces.
- Refer to allowable load-adjustment factors for spacing and edge distance on pages 198 and 199.
- The minimum concrete thickness is 1½ times the embedment depth.
- Allowable load may be interpolated for concrete compressive strengths between 2,000 psi and 4,000 psi.

* See page 12 for an explanation of the load table icons.

Wood Rod Hanger Threaded Rod Anchor System

Simpson Strong-Tie's wood rod hanger is a one-piece fastening system for suspending 1/4" or 3/8" threaded rod. Vertical rod hangers are designed to suspend threaded rod in overhead applications from wood members. Horizontal rod hangers are available for applications requiring installation into the side of joists, columns and overhead members. Both rod hangers provide attachment points for use in pipe hanging, fire protection, electrical conduit and cable-tray applications. Recommended for use in dry, interior, non-corrosive environments only.

Features

- Threaded anchors for rod-hanging applications in wood
- Suitable for installation horizontally or vertically in overhead applications
- No pre-drilling required
- Easily installed with a drill or screw gun
- Type-17 tip provides for fast starts
- UL/FM Listed

Material: Carbon steel

Coating: Zinc plated



Vertical Wood Rod Hanger (RWW)

Horizontal Wood Rod Hanger (RWH)

Wood Rod Hangers

Rod Diameter in.	Size	Model No.	Application	Point Style	Quantity	
					Box	Carton
1/4	1/4" x 2"	RWW25200	Vertical	Type 17	25	250
3/8	1/4" x 1"	RWW37100				
3/8	1/4" x 2"	RWW37200				
3/8	5/16" x 2 1/2"	RWW37212				
1/4	1/4" x 1"	RWH25100	Horizontal	Type 17	25	250
3/8	1/4" x 2"	RWH37200				
3/8	1/4" x 2"	RWH37200				
3/8	5/16" x 2 1/2"	RWH37212				



Type-17 point for use in wood

Nut Driver

Model No.	Description	Quantity	
		Box	Carton
RND62	Nut Driver	1 blister	10



Nut Driver RND62

Wood Rod Hanger Design Information — Wood



Vertical Wood Rod Hanger Allowable Loads

Model No.	Rod Diameter (in.)	Size (in.)	Minimum Edge Dist. (in.)	Minimum End Dist. (in.)	Minimum Spacing (in.)	Loads							
						DF		SP		SPF		UL Approval Pipe Size in.	FM Approval Pipe Size in.
						Ultimate lb.	Allowable lb.	Ultimate lb.	Allowable lb.	Ultimate lb.	Allowable lb.		
RWW25200	¼	¼ x 2	¾	2¾	2¾	1,875	375	2,165	435	1,540	310	—	—
RWW37100	⅜	¼ x 1				765	155	950	190	525	105	—	—
RWW37200	⅜	¼ x 2				1,875	375	2,165	435	1,540	310	3	—
RWW37212	⅜	5/16 x 2½		3¼	3¼	3,015	605	2,960	590	2,470	495	4	4

1. Load values are based on full shank penetration into the wood member.
2. Allowable loads may be increased by CD = 1.6 for wind or earthquake.
3. Allowable loads are based on a factor of safety of 5.0.
4. Mechanical and plumbing design codes may prescribe lower allowable loads. Verify with local codes.
5. Allowable loads are based on Douglas Fir-Larch (DF), Southern Pine (SP) and Spruce-Pine-Fir (SPF) wood members having a minimum specific gravity of 0.50, 0.55 and 0.42, respectively.



Horizontal Wood Rod Hanger Allowable Loads

Model No.	Rod Diameter (in.)	Size (in.)	Minimum Edge Distance (in.)	Minimum End Distance (in.)	Minimum Spacing (in.)	Loads						
						DF		SP		SPF		UL Approval Pipe Size (in.)
						Ultimate lb.	Allowable lb.	Ultimate lb.	Allowable lb.	Ultimate lb.	Allowable lb.	
RWH25100	¼	¼ x 1	1	2¾	2¾	555	110	680	135	430	85	—
RWH37200	⅜	¼ x 2	2½			1,205	240	1,115	225	1,650	330	3
RWH37212	⅜	5/16 x 2½		3¼	3¼	1,145	230	1,320	265	1,190	240	3

1. Load values are based on full shank penetration into the wood member.
2. Allowable loads may not be increased for short-term loading.
3. Allowable loads are based on a factor of safety of 5.0.
4. Mechanical and plumbing design codes may prescribe lower allowable loads. Verify with local codes.
5. Allowable loads are based on Douglas Fir-Larch (DF), Southern Pine (SP) and Spruce-Pine-Fir (SPF) wood members having a minimum specific gravity of 0.50, 0.55 and 0.42, respectively.

Installation Sequence

1. Attach RND62 nut driver to a drill.
2. Insert rod hanger into the RND62 nut driver.
3. Using rotation-only mode, drive rod hanger until it contacts the surface. Do not over-tighten. RND62 nut driver will disengage the rod hanger at the appropriate depth to prevent over-driving.
4. Insert threaded rod. Minimum thread engagement should be equal to the nominal diameter of the threaded insert.

Vertical Wood Rod Hanger

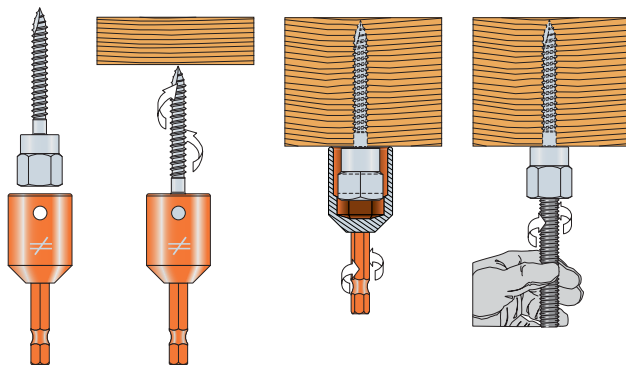

Horizontal Wood Rod Hanger

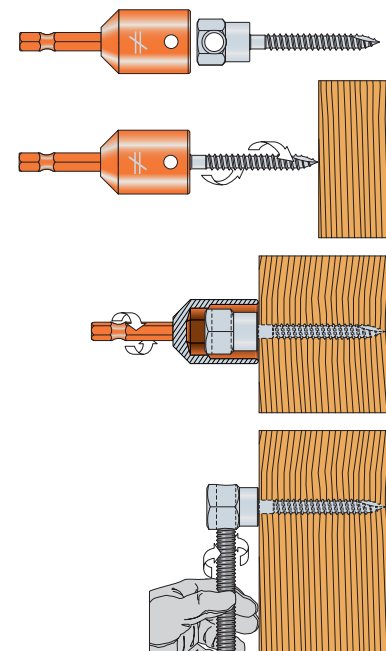

* See page 12 for an explanation of the load table icons.

Blue Banger Hanger® Cast-In-Place, Internally Threaded Insert

Wood-Form Insert

Multi-thread, cast-in-place wood-form and metal-deck inserts for cracked and uncracked concrete maximize jobsite efficiency and reduce inventory commitment. Also available in metal-roof-deck insert version, offering a low-profile design that does not interfere with roofing material.



Features

- Code listed under the IBC/IRC in accordance with AC446 for cracked and uncracked concrete applications, per ICC-ES ESR-3707
- Multi-thread design allows insert to accept multiple rod diameters
- Blue plastic ring acts as an insert locator when forms are removed
- Plastic ring creates a countersunk recess to keep internal threads clean from concrete residue
- Nails snap off with a hammer strike after the forms are removed

Material: Carbon steel

Coating: Yellow zinc dichromate coating

Codes: ICC-ES ESR-3707; Factory Mutual 3024378 (see pipe size limit tables); Underwriters Laboratories File Ex3605 (see pipe size limit tables)

Installation

1. Strike the top of the hanger and drive the 3 mounting nails into the forming material until the bottom of the hanger is flush with the bottom of the plywood. The hanger should be sitting 90° from the forming material.
2. Once concrete is hardened and forms are stripped, strike the mounting nails to break them off.
3. Insert the rod into the sleeve and thread it into the hanger.



Installation Sequence

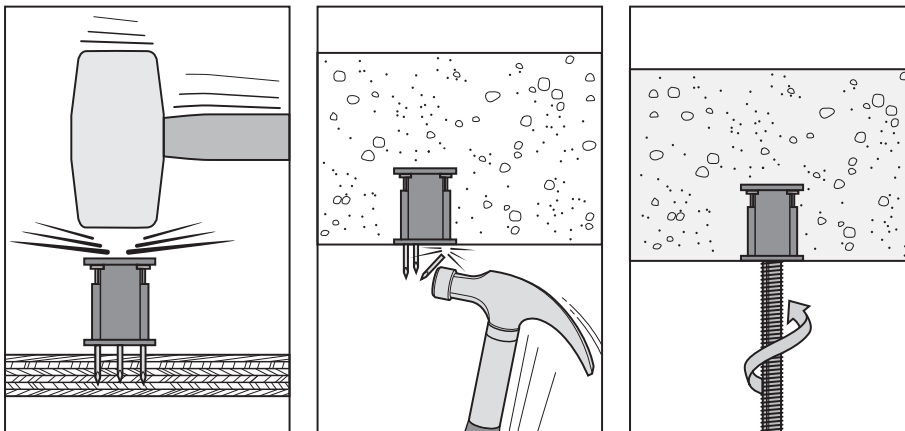

Patented multi-thread design allows one product to handle up to three rod diameters.

Product Data

Hanger Type	For Rod Diameter (in)	Model Number	Carton Qty.
Wood-Form Insert	1/4, 3/8, 1/2	BBWF2550	200
	3/8, 1/2, 5/8	BBWF3762	150
	5/8, 3/4	BBWF6275	150



Blue Banger Hanger® Cast-In-Place, Internally Threaded Insert

Metal-Deck Insert



Features

- Code-listed under the IBC/IRC in accordance with AC446 for cracked and uncracked concrete applications, per ICC-ES ESR-3707
- Multi-thread design allows insert to accept multiple rod diameters
- Compression spring keeps insert perpendicular to deck, even if bumped or stepped on after installation
- 3" plastic sleeve keeps internal threads clean and provides guidance to align threaded rod with the internal threads
- Extended sleeve length allows easy location of insert even with fireproofing on the underside of the deck
- Installed height of 2" allows insert to be used on top of or between deck flutes

Material: Carbon steel

Coating: Yellow zinc dichromate coating

Codes: ICC-ES ESR-3707; Factory Mutual 3024378 (see pipe size limit tables); Underwriters Laboratories File Ex3605 (see pipe size limit tables)

Installation

1. Drill a hole in the metal deck using the appropriate diameter bit as referenced in the table.
2. Insert the hanger in the hole and strike the top so that the plastic sleeve is forced through the hole and expands against the bottom side of the deck. The anchor can also be installed by stepping on it.
3. Insert the rod into the sleeve and thread it into the hanger.



Mechanical Anchors

Installation Sequence

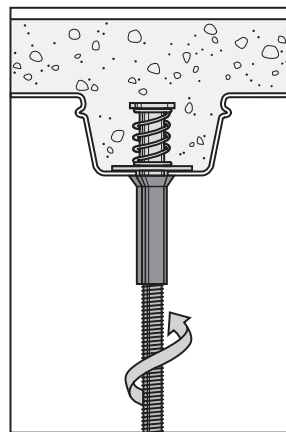
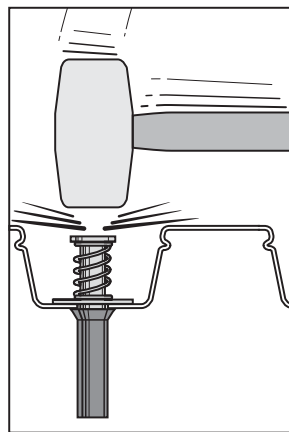
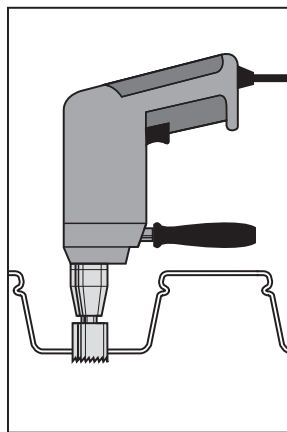

Patented multi-thread design allows one product to handle up to three rod diameters.

Product Data

Hanger Type	For Rod Diameter (in)	Deck Hole Diameter (in)	Model Number	Carton Qty.
Metal-Deck Insert	1/4, 3/8, 1/2	13/16 - 7/8	BBMD2550	100
	3/8, 1/2, 5/8	1 1/8 - 1 3/16	BBMD3762	50
	5/8, 3/4	1 3/16 - 1 1/4	BBMD6275	50



Blue Banger Hanger® Cast-In-Place, Internally Threaded Insert

Metal-Roof-Deck Insert

Features

- Multi-thread design: The insert accepts three different rod diameters
- Low-profile design does not interfere with roofing material
- Positive attachment to the roof deck prevents spinning and keeps the hanger in position
- Pre-staked, self-drilling screws allow quick installation

Material: Carbon steel

Coating: Yellow zinc dichromate coating

Installation

1. Drill a hole in the metal deck using the appropriate diameter bit as referenced in the table.
2. Insert the hanger into the hole and fasten to the deck with the two pre-staked screws provided.
3. Insert the rod into the sleeve and thread it into the hanger.



Installation Sequence

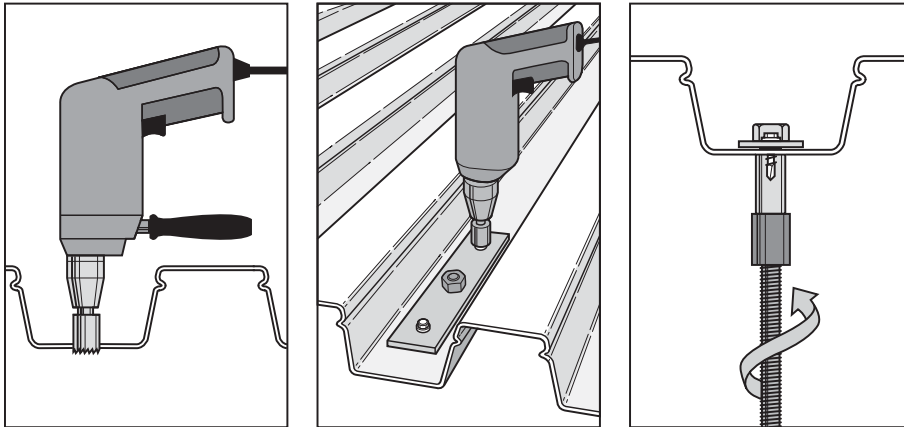

Product Data

Hanger Type	For Rod Diameter (in.)	Deck Hole Diameter (in.)	Model Number	Carton Qty.
Roof-Deck Insert	1/4, 3/8, 1/2	7/8	BBRD2550	50

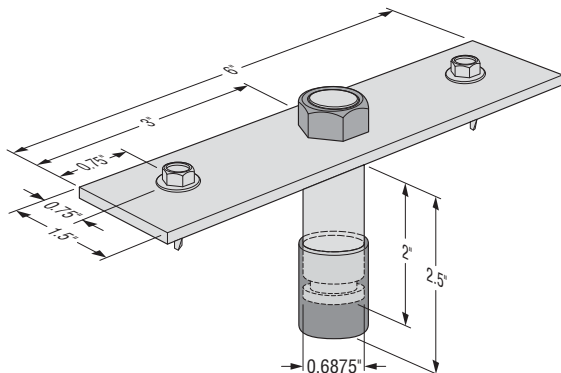

Blue Banger Hanger® Design Information — Concrete



Wood-Form Insert: Tension and Shear Strength Design Data^{1,2,3,4,5,6,8}

Design Information	Symbol	Units	Model No.		
			BBWF2550	BBWF3762	BBWF6275
Insert outside diameter ⁷	d_a	in.	0.811	1.00	1.102
Effective embedment depth	h_{ef}	in.	1.875	1.954	1.875
Insert steel characterization	—	—	Non-ductile		
Modification factor for insert tension strength for inserts located in a region of a concrete member where analysis indicates no cracking at service load levels	$\Psi_{c,N}$	—	1.25	1.25	1.25
Nominal tension strength of single insert in tension as governed by steel strength	$N_{sa,insert}$	lb.	8,415	16,755	18,685
Nominal seismic tension strength of single insert in tension as governed by steel strength	$N_{sa,insert,eq}$	lb.	7,695	8,195	7,695
Nominal steel shear strength of single insert	V_{sa}	lb.	6,810	8,210	8,760
Nominal steel shear strength of single insert for seismic loading	$V_{sa,eq}$	lb.	6,810	8,210	8,760

- Concrete must be normal-weight or lightweight concrete with f'_c of 3,000 psi minimum.
- Only the largest size of threaded rod specified for each insert must be used for applications resisting shear loads.
- Design of headed cast-in specialty inserts shall be in accordance with the provisions of ACI 318 Appendix D for cast-in headed anchors. The value of k_c shall be in accordance with the value for cast-in anchors in D.5.2.2.
- Strength reduction factors shall be taken from ACI 318-11 D.4.3 for cast-in headed anchors.
- Strength reduction factor for load combinations of ACI 318 Section 9.2 governed by steel strength shall be taken as 0.65 for tension and 0.60 for shear.
- The concrete tension strength of headed cast-in specialty inserts shall be calculated in accordance with ACI 318 Appendix D.
- Insert outside diameter = outside diameter of plastic sleeve.
- The strengths shown in the table are for inserts only. Design professional is responsible for checking threaded rod strength in tension, shear and combined tension and shear, as applicable.



Metal-Deck Insert: Tension and Shear Strength Design Data^{1,2,3,4,5,6,8}

Design Information	Symbol	Units	Model No.		
			BBMD2550	BBMD3762	BBMD6275
Insert outside diameter ⁷	d_a	in.	0.94	1.16	1.29
Effective embedment depth	h_{ef}	in.	1.98	1.98	1.98
Insert steel characterization	—	—	Non-ductile		
Modification factor for insert tension strength for inserts located in a region of a concrete member where analysis indicates no cracking at service load levels	$\Psi_{c,N}$	—	1.25	1.25	1.25
Nominal tension strength of single insert in tension as governed by steel strength	$N_{sa,insert}$	lb.	10,085	16,655	14,200
Nominal seismic tension strength of single insert in tension as governed by steel strength	$N_{sa,insert,eq}$	lb.	7,920	7,920	7,920
Nominal steel shear strength of single insert in the soffit of concrete on metal deck, lower flute	$V_{sa,deck,lower}$	lb.	3,105	2,610	3,345
Nominal steel shear strength of single insert in the soffit of concrete on metal deck, upper flute	$V_{sa,deck,upper}$	lb.	3,500	1,710	5,565
Nominal steel shear strength of single insert in the soffit of concrete on metal deck, for seismic loading, lower flute	$V_{sa,deck,lower,eq}$	lb.	3,105	2,610	3,345
Nominal steel shear strength of single insert in the soffit of concrete on metal deck, for seismic loading, upper flute	$V_{sa,deck,upper,eq}$	lb.	3,500	1,710	5,565

- Concrete must be normal-weight or lightweight concrete with f'_c of 3,000 psi minimum.
- Only the largest size of threaded rod specified for each insert must be used for applications resisting shear loads.
- Design of headed cast-in specialty inserts shall be in accordance with the provisions of ACI 318 Appendix D for cast-in headed anchors. The value of k_c shall be in accordance with the value for cast-in anchors in D.5.2.2.
- Strength reduction factors shall be taken from ACI 318-11 D.4.3 for cast-in headed anchors.
- Strength reduction factor for load combinations of ACI 318 Section 9.2 governed by steel strength shall be taken as 0.65 for tension and 0.60 for shear.
- The concrete tension strength of headed cast-in specialty inserts in the soffit of concrete on metal deck assemblies shall be calculated in accordance with ACI 318 Appendix D and Figure 1.
- Insert outside diameter = outside diameter of plastic sleeve.
- The strengths shown in the table are for inserts only. Design professional is responsible for checking threaded rod strength in tension, shear and combined tension and shear, and the influence of bending on tension values when loaded in shear, as applicable.

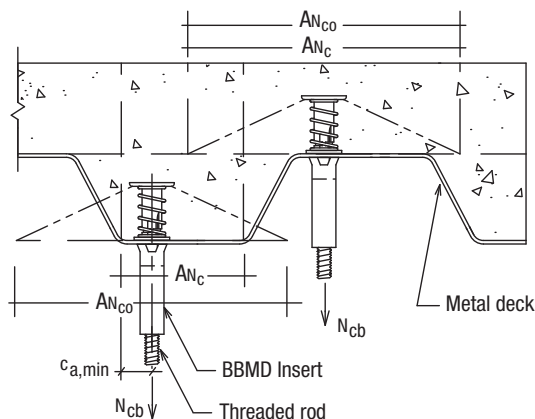

Figure 1.

Idealization of concrete on deck; determination of concrete breakout strength in accordance with ACI 318.

* See page 12 for an explanation of the load table icons.

Blue Banger Hanger® Design Information — Concrete



Wood-Form Insert: Tension Design Strengths in Normal-Weight Concrete ($f'_c = 3,000$ psi)

Model No.	Threaded Rod Dia. (in.)	Nominal Embed. Depth (in.)	Min. Concrete Thickness h_{min} (in.)	Critical Edge Distance c_{ac} (in.)	Minimum Edge Distance c_{min} (in.)	Tension Design Strength Based on Concrete (lb.)							
						Edge Distances = c_{ac} on all sides				Edge Distances = c_{min} on one side and c_{ac} on three sides			
						SDC A-B ⁵		SDC C-F ^{6,7}		SDC A-B ⁵		SDC C-F ^{6,7}	
						Uncracked	Cracked	Uncracked	Cracked	Uncracked	Cracked	Uncracked	Cracked
BBWF2550	1/4	2	2 3/4	3	1 1/2	2,955	2,365	2,215	1,770	1,950	1,560	1,460	1,170
	3/8												
	1/2												
BBWF3762	3/8	2	2 3/4	3	1 9/16	3,140	2,515	2,355	1,885	2,070	1,655	1,550	1,240
	1/2												
	5/8												
BBWF6275	5/8	2	2 3/4	3	1 5/8	2,955	2,365	2,215	1,770	2,040	1,630	1,530	1,225
	3/4												

Threaded Rod Dia. (in.)	Tension Design Strength of Threaded Rod Steel (lb.)							
	ASTM F1554 GR 36	ASTM F1554 GR 55	ASTM F1554 GR 105	ASTM A307	ASTM A325	ASTM A193 B6	ASTM A193 B7	ASTM A193 B8/B8M
1/4	1,385	1,790	2,980	1,435	2,860	2,625	2,980	1,360
3/8	3,370	4,360	7,270	3,490	6,975	6,395	7,270	3,310
1/2	6,175	7,990	13,315	6,390	12,780	11,715	13,315	6,070
5/8	9,835	12,715	21,190	10,170	20,340	18,645	21,190	9,660
3/4	14,530	18,790	31,315	15,030	30,060	27,555	31,315	14,280

1. Tension design strength must be the lesser of the concrete or threaded rod strength.
2. Tension design strengths are based on the strength design provisions of ACI 318-11 Appendix D.
3. Tabulated values are for a single anchor with no influence of another anchor.
4. Strength reduction factor, ϕ , is based on using a load combination from ACI 318-11 Section 9.2.
5. The tension design strength listed for SDC (Seismic Design Category) A-B may also be used in SDC C-F when the tension component of the strength-level seismic design load on the anchor does not exceed 20% of the total factored tension load on the anchor associated with the same load combination.
6. When designing anchorages in SDC C-F, the designer shall consider the ductility requirements of ACI 318-11 Section D.3.3.
7. Tension design strengths in SDC C-F have been adjusted by 0.75 factor in accordance with ACI 318-11 Section D.3.3.4.4.

Wood-Form Insert: Allowable Tension Loads in Normal-Weight Concrete ($f'_c = 3,000$ psi) — Static Load



Model No.	Threaded Rod Dia. (in.)	Nominal Embed. Depth (in.)	Min. Concrete Thickness h_{min} (in.)	Critical Edge Distance c_{ac} (in.)	Minimum Edge Distance c_{min} (in.)	Allowable Tension Load Based on Concrete (lb.)			
						Edge Distances = c_{ac} on all sides		Edge Distances = c_{min} on one side and c_{ac} on three sides	
						Uncracked	Cracked	Uncracked	Cracked
BBWF2550	1/4	2	2 3/4	3	1 1/2	2,110	1,690	1,395	1,115
	3/8								
	1/2								
BBWF3762	3/8	2	2 3/4	3	1 9/16	2,245	1,795	1,480	1,180
	1/2								
	5/8								
BBWF6275	5/8	2	2 3/4	3	1 5/8	2,110	1,690	1,455	1,165
	3/4								

Threaded Rod Dia. (in.)	Allowable Tension Load of Threaded Rod Steel (lb.)							
	ASTM F1554 GR 36	ASTM F1554 GR 55	ASTM F1554 GR 105	ASTM A307	ASTM A325	ASTM A193 B6	ASTM A193 B7	ASTM A193 B8/B8M
1/4	990	1,280	2,130	1,025	2,045	1,875	2,130	970
3/8	2,405	3,115	5,195	2,495	4,980	4,570	5,195	2,365
1/2	4,410	5,705	9,510	4,565	9,130	8,370	9,510	4,335
5/8	7,025	9,080	15,135	7,265	14,530	13,320	15,135	6,900
3/4	10,380	13,420	22,370	10,735	21,470	19,680	22,370	10,200

1. Allowable tension load must be the lesser of the concrete or threaded rod steel load.
2. Allowable tension loads are calculated based on the strength design provision of ACI 318-11 Appendix D using a conversion factor of $\alpha = 1.4$. The conversion factor α is based on the load combination 1.2D + 1.6L assuming 50% dead load and 50% live load: $1.2(0.5) + 1.6(0.5) = 1.4$.
3. Tabulated values are for a single anchor with no influence of another anchor.

* See page 12 for an explanation of the load table icons.

Blue Banger Hanger® Design Information — Concrete

Wood-Form Insert: Allowable Tension Loads in Normal-Weight Concrete ($f'_c = 3,000$ psi) — Wind Load



Model No.	Threaded Rod Dia. (in.)	Nominal Embed. Depth (in.)	Min. Concrete Thickness h_{min} (in.)	Critical Edge Distance c_{ac} (in.)	Minimum Edge Distance c_{min} (in.)	Allowable Tension Load Based on Concrete (lb.)			
						Edge Distances = c_{ac} on all sides		Edge Distances = c_{min} on one side and c_{ac} on three sides	
						Uncracked	Cracked	Uncracked	Cracked
BBWF2550	1/4	2	2 3/4	3	1 1/2	1,775	1,420	1,170	935
	3/8								
	1/2								
BBWF3762	3/8	2	2 3/4	3	1 9/16	1,885	1,510	1,240	995
	1/2								
	5/8								
BBWF6275	5/8	2	2 3/4	3	1 5/8	1,775	1,420	1,225	980
	3/4								

Threaded Rod Dia. (in.)	Allowable Tension Load of Threaded Rod Steel (lb.)							
	ASTM F1554 GR 36	ASTM F1554 GR 55	ASTM F1554 GR 105	ASTM A307	ASTM A325	ASTM A193 B6	ASTM A193 B7	ASTM A193 B8/B8M
1/4	830	1,075	1,790	860	1,715	1,575	1,790	815
3/8	2,020	2,615	4,360	2,095	4,185	3,835	4,360	1,985
1/2	3,705	4,795	7,990	3,835	7,670	7,030	7,990	3,640
5/8	5,900	7,630	12,715	6,100	12,205	11,185	12,715	5,795
3/4	8,720	11,275	18,790	9,020	18,035	16,535	18,790	8,570

1. Allowable tension load must be the lesser of the concrete or threaded rod steel load.
2. Allowable tension loads are calculated based on the strength design provision of ACI 318-11 Appendix D using a conversion factor of $\alpha = 1/6.6 = 1.67$. The conversion factor α is based on the load combination assuming 100% wind load.
3. Tabulated values are for a single anchor with no influence of another anchor.

Wood-Form Insert: Allowable Tension Loads in Normal-Weight Concrete ($f'_c = 3,000$ psi) — Seismic Load



Model No.	Threaded Rod Dia. (in.)	Nominal Embed. Depth (in.)	Min. Concrete Thickness h_{min} (in.)	Critical Edge Distance c_{ac} (in.)	Minimum Edge Distance c_{min} (in.)	Allowable Tension Load Based on Concrete (lb.)							
						Edge Distances = c_{ac} on all sides				Edge Distances = c_{min} on one side and c_{ac} on three sides			
						SDC A-B ⁴		SDC C-F ^{5,6}		SDC A-B ⁴		SDC C-F ^{5,6}	
						Uncracked	Cracked	Uncracked	Cracked	Uncracked	Cracked	Uncracked	Cracked
BBWF2550	1/4	2	2 3/4	3	1 1/2	2,070	1,655	1,550	1,240	1,365	1,090	1,020	820
	3/8												
	1/2												
BBWF3762	3/8	2	2 3/4	3	1 9/16	2,200	1,760	1,650	1,320	1,450	1,160	1,085	870
	1/2												
	5/8												
BBWF6275	5/8	2	2 3/4	3	1 5/8	2,070	1,655	1,550	1,240	1,430	1,140	1,070	860
	3/4												

Threaded Rod Dia. (in.)	Allowable Tension Load of Threaded Rod Steel (lb.)							
	ASTM F1554 GR 36	ASTM F1554 GR 55	ASTM F1554 GR 105	ASTM A307	ASTM A325	ASTM A193 B6	ASTM A193 B7	ASTM A193 B8/B8M
1/4	970	1,255	2,085	1,005	2,000	1,840	2,085	950
3/8	2,360	3,050	5,090	2,445	4,885	4,475	5,090	2,315
1/2	4,325	5,595	9,320	4,475	8,945	8,200	9,320	4,250
5/8	6,885	8,900	14,835	7,120	14,240	13,050	14,835	6,760
3/4	10,170	13,155	21,920	10,520	21,040	19,290	21,920	9,995

1. Allowable tension load must be the lesser of the concrete or threaded rod steel load.
2. Allowable tension loads are calculated based on the strength design provision of ACI 318-11 Appendix D using a conversion factor of $\alpha = 1/6.7 = 1.43$. The conversion factor α is based on the load combination assuming 100% seismic load.
3. Tabulated values are for a single anchor with no influence of another anchor.
4. The allowable tension load listed for SDC (Seismic Design Category) A-B may also be used in SDC C-F when the tension component of the strength-level seismic design load on the anchor does not exceed 20% of the total factored tension load on the anchor associated with the same load combination.
5. When designing anchorages in SDC C-F, the designer shall consider the ductility requirements of ACI 318-11 Section D.3.3.
6. Tension design strengths in SDC C-F have been adjusted by 0.75 factor in accordance with ACI 318-11 Section D.3.3.4.4.

* See page 12 for an explanation of the load table icons.

Blue Banger Hanger® Design Information — Concrete

Metal-Deck Insert: Tension Design Strength in Soffit of Normal-Weight or Sand-Lightweight Concrete-Filled Profile Steel Deck Assemblies ($f'_c = 3,000$ psi)



Model No.	Threaded Rod Dia. (in.)	Nominal Embed. Depth (in.)	Minimum End Distance c_{min} (in.)	Tension Design Strength Based on Concrete (lb.)							
				Lower Flute				Upper Flute			
				SDC A-B ⁵		SDC C-F ^{6,7}		SDC A-B ⁵		SDC C-F ^{6,7}	
				Uncracked	Cracked	Uncracked	Cracked	Uncracked	Cracked	Uncracked	Cracked
BBMD2550	1/4	2	2 1/8	1,930	1,545	1,445	1,155	2,510	2,010	1,885	1,505
	3/8										
	1/2										
BBMD3762	3/8	2	2 1/2	2,075	1,660	1,555	1,245	2,810	2,250	2,110	1,685
	1/2										
	5/8										
BBMD6275	5/8	2	2 1/2	2,075	1,660	1,555	1,245	2,810	2,250	2,110	1,685
	3/4										

Threaded Rod Dia. (in.)	Tension Design Strength of Threaded Rod Steel (lb.)							
	ASTM F1554 GR 36	ASTM F1554 GR 55	ASTM F1554 GR 105	ASTM A307	ASTM A325	ASTM A193 B6	ASTM A193 B7	ASTM A193 B8/B8M
1/4	1,385	1,790	2,980	1,435	2,860	2,625	2,980	1,360
3/8	3,370	4,360	7,270	3,490	6,975	6,395	7,270	3,310
1/2	6,175	7,990	13,315	6,390	12,780	11,715	13,315	6,070
5/8	9,835	12,715	21,190	10,170	20,340	18,645	21,190	9,660
3/4	14,530	18,790	31,315	15,030	30,060	27,555	31,315	14,280

1. Tension design strength must be the lesser of the concrete or threaded rod strength.
2. Tension design strengths are based on the strength design provisions of ACI 318-11 Appendix D.
3. Tabulated values are for a single anchor with no influence of another anchor.
4. Strength reduction factor, ϕ , is based on using a load combination from ACI 318-11 Section 9.2.
5. The tension design strength listed for SDC (Seismic Design Category) A-B may also be used in SDC C-F when the tension component of the strength-level seismic design load on the anchor does not exceed 20% of the total factored tension load on the anchor associated with the same load combination.
6. When designing anchorages in SDC C-F, the designer shall consider the ductility requirements of ACI 318-11 Section D.3.3.
7. Tension design strengths in SDC C-F have been adjusted by 0.75 factor in accordance with ACI 318-11 Section D.3.3.4.4.
8. Installation must comply with Figure 1 on page 223.

Metal-Deck Insert: Allowable Tension Loads in Soffit of Normal-Weight or Sand-Lightweight Concrete-Filled Profile Steel Deck Assemblies ($f'_c = 3,000$ psi) — Static Load

Model No.	Threaded Rod Dia. (in.)	Nominal Embed. Depth (in.)	Minimum End Distance c_{min} (in.)	Allowable Tension Load Based on Concrete (lb.)			
				Lower Flute		Upper Flute	
				Uncracked	Cracked	Uncracked	Cracked
BBMD2550	1/4	2	2 1/8	1,380	1,105	1,795	1,435
	3/8						
	1/2						
BBMD3762	3/8	2	2 1/2	1,480	1,185	2,005	1,605
	1/2						
	5/8						
BBMD6275	5/8	2	2 1/2	1,480	1,185	2,005	1,605
	3/4						

Threaded Rod Dia. (in.)	Allowable Tension Load of Threaded Rod Steel (lb.)							
	ASTM F1554 GR 36	ASTM F1554 GR 55	ASTM F1554 GR 105	ASTM A307	ASTM A325	ASTM A193 B6	ASTM A193 B7	ASTM A193 B8/B8M
1/4	990	1,280	2,130	1,025	2,045	1,875	2,130	970
3/8	2,405	3,115	5,195	2,495	4,980	4,570	5,195	2,365
1/2	4,410	5,705	9,510	4,565	9,130	8,370	9,510	4,335
5/8	7,025	9,080	15,135	7,265	14,530	13,320	15,135	6,900
3/4	10,380	13,420	22,370	10,735	21,470	19,680	22,370	10,200

1. Allowable tension load must be the lesser of the concrete or threaded rod steel load.
2. Allowable tension loads are calculated based on the strength design provision of ACI 318-11 Appendix D using a conversion factor of $\alpha = 1.4$. The conversion factor α is based on the load combination $1.2D + 1.6L$ assuming 50% dead load and 50% live load: $1.2(0.5) + 1.6(0.5) = 1.4$.
3. Tabulated values are for a single anchor with no influence of another anchor.
4. Installation must comply with Figure 1 on page 223.

* See page 12 for an explanation of the load table icons.

Blue Banger Hanger® Design Information — Concrete

Metal-Deck Insert: Allowable Tension Loads in Soffit of Normal-Weight or Sand-Lightweight Concrete-Filled Profile Steel Deck Assemblies ($f'_c = 3,000$ psi) — Wind Load

Model No.	Threaded Rod Dia. (in.)	Nominal Embed. Depth (in.)	Minimum End Distance c_{min} (in.)	Allowable Tension Load Based on Concrete (lb.)			
				Lower Flute		Upper Flute	
				Uncracked	Cracked	Uncracked	Cracked
BBMD2550	1/4	2	2 1/8	1,160	925	1,505	1,205
	3/8						
	1/2						
BBMD3762	3/8	2	2 1/2	1,245	995	1,685	1,350
	1/2						
	5/8						
BBMD6275	5/8	2	2 1/2	1,245	995	1,685	1,350
	3/4						



Threaded Rod Dia. (in.)	Allowable Tension Load of Threaded Rod Steel (lb.)							
	ASTM F1554 GR 36	ASTM F1554 GR 55	ASTM F1554 GR 105	ASTM A307	ASTM A325	ASTM A193 B6	ASTM A193 B7	ASTM A193 B8/B8M
1/4	830	1,075	1,790	860	1,715	1,575	1,790	815
3/8	2,020	2,615	4,360	2,095	4,185	3,835	4,360	1,985
1/2	3,705	4,795	7,990	3,835	7,670	7,030	7,990	3,640
5/8	5,900	7,630	12,715	6,100	12,205	11,185	12,715	5,795
3/4	8,720	11,275	18,790	9,020	18,035	16,535	18,790	8,570

1. Allowable tension load must be the lesser of the concrete or threaded rod steel load.
2. Allowable tension loads are calculated based on the strength design provision of ACI 318-11 Appendix D using a conversion factor of $\alpha = 1/6.6 = 1.67$. The conversion factor α is based on the load combination assuming 100% wind load.
3. Tabulated values are for a single anchor with no influence of another anchor.
4. Installation must comply with Figure 1 on page 223.

Metal-Deck Insert: Allowable Tension Loads in Soffit of Normal-Weight or Sand-Lightweight Concrete-Filled Profile Steel Deck Assemblies ($f'_c = 3,000$ psi) — Seismic Load

Model No.	Threaded Rod Dia. (in.)	Nominal Embed. Depth (in.)	Minimum End Distance c_{min} (in.)	Allowable Tension Load Based on Concrete (lb.)							
				Lower Flute				Upper Flute			
				SDC A-B ⁴		SDC C-F ^{5,6}		SDC A-B ⁴		SDC C-F ^{5,6}	
Uncracked	Cracked	Uncracked	Cracked	Uncracked	Cracked	Uncracked	Cracked	Uncracked	Cracked		
BBMD2550	1/4	2	2 1/8	1,350	1,080	1,010	810	1,755	1,405	1,320	1,055
	3/8										
	1/2										
BBMD3762	3/8	2	2 1/2	1,455	1,160	1,090	870	1,965	1,575	1,475	1,180
	1/2										
	5/8										
BBMD6275	5/8	2	2 1/2	1,455	1,160	1,090	870	1,965	1,575	1,475	1,180
	3/4										



Threaded Rod Dia. (in.)	Allowable Tension Load of Threaded Rod Steel (lb.)							
	ASTM F1554 GR 36	ASTM F1554 GR 55	ASTM F1554 GR 105	ASTM A307	ASTM A325	ASTM A193 B6	ASTM A193 B7	ASTM A193 B8/B8M
1/4	970	1,255	2,085	1,005	2,000	1,840	2,085	950
3/8	2,360	3,050	5,090	2,445	4,885	4,475	5,090	2,315
1/2	4,325	5,595	9,320	4,475	8,945	8,200	9,320	4,250
5/8	6,885	8,900	14,835	7,120	14,240	13,050	14,835	6,760
3/4	10,170	13,155	21,920	10,520	21,040	19,290	21,920	9,995

1. Allowable tension load must be the lesser of the concrete or threaded rod steel load.
2. Allowable tension loads are calculated based on the strength design provision of ACI 318-11 Appendix D using a conversion factor of $\alpha = 1/6.7 = 1.43$. The conversion factor α is based on the load combination assuming 100% seismic load.
3. Tabulated values are for a single anchor with no influence of another anchor.
4. The allowable tension load listed for SDC (Seismic Design Category) A-B may also be used in SDC C-F when the tension component of the strength-level seismic design load on the anchor does not exceed 20% of the total factored tension load on the anchor associated with the same load combination.
5. When designing anchorages in SDC C-F, the designer shall consider the ductility requirements of ACI 318-11 Section D.3.3.
6. Tension design strengths in SDC C-F have been adjusted by 0.75 factor in accordance with ACI 318-11 Section D.3.3.4.4.
7. Installation must comply with Figure 1 on page 223.

* See page 12 for an explanation of the load table icons.

Blue Banger Hanger® Design Information — Concrete

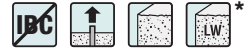

Wood-Form Insert: Allowable Tension Loads in Normal-Weight or Sand-Lightweight Concrete

Model No.	Threaded Rod Dia. in.	Embed. Depth in. (mm)	Min. Edge Dist. in. (mm)	Min. Spacing in. (mm)	Tension Load Based on Concrete Strength (Normal Weight)		Tension Load Based on Rod Strength (Normal Weight)	Tension Load Based on Concrete Strength (Sand-Lightweight)		Tension Load Based on Rod Strength (Sand-Lightweight)
					$f'_c \geq 3,000$ psi (20.7 MPa)		F1554 Grade 36	$f'_c \geq 3,000$ psi (20.7 MPa)		F1554 Grade 36
					Ultimate lb. (kN)	Allowable lb. (kN)	Allowable lb. (kN)	Ultimate lb. (kN)	Allowable lb. (kN)	Allowable lb. (kN)
BBWF2550	1/4	2 (51)	7 (178)	8 (203)	6,820 (30.3)	1,705 (7.6)	940 (4.2)	4,280 (19.0)	1,070 (4.8)	940 (4.2)
	3/8						2,105 (9.4)			2,105 (9.4)
	1/2						3,750 (16.7)			3,750 (16.7)
BBWF3762	3/8	2 (51)	7 (178)	8 (203)	7,360 (32.7)	1,840 (8.2)	2,105 (9.4)	—	—	—
	1/2						3,750 (16.7)			—
	5/8						5,875 (26.1)			—
BBWF6275	5/8	2 (51)	7 (178)	8 (203)	7,420 (33.0)	1,855 (8.3)	5,875 (26.1)	4,400 (19.6)	1,100 (4.9)	5,875 (26.1)
	3/4						8,460 (37.6)			8,460 (37.6)

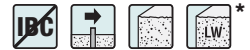

Wood-Form Insert: Allowable Shear Loads in Normal-Weight or Sand-Lightweight Concrete

Model No.	Threaded Rod Dia. in.	Embed. Depth in. (mm)	Min. Edge Dist. in. (mm)	Min. Spacing in. (mm)	Shear Load Based on Concrete Strength (Normal Weight)		Shear Load Based on Rod Strength (Normal Weight)	Shear Load Based on Concrete Strength (Sand-Lightweight)		Tension Load Based on Rod Strength (Sand-Lightweight)
					$f'_c \geq 3,000$ psi (20.7 MPa)		F1554 Grade 36	$f'_c \geq 3,000$ psi (20.7 MPa)		F1554 Grade 36
					Ultimate lb. (kN)	Allowable lb. (kN)	Allowable lb. (kN)	Ultimate lb. (kN)	Allowable lb. (kN)	Allowable lb. (kN)
BBWF2550	1/2	2 (51)	7 (178)	8 (203)	8,750 (38.9)	2,185 (9.7)	1,930 (8.6)	8,600 (38.2)	2,150 (9.6)	1,930 (8.6)
BBWF3762	5/8	2 (51)	7 (178)	8 (203)	10,700 (47.6)	2,675 (11.9)	3,025 (13.4)	—	—	—
BBWF6275	3/4	2 (51)	7 (178)	8 (203)	10,460 (46.5)	2,615 (11.6)	4,360 (19.4)	9,260 (41.2)	2,315 (38.9)	4,360 (19.4)

1. Allowable load must be the lesser of the concrete or steel strength.
2. The allowable loads based on concrete strength are based on a factor of safety of 4.0.
3. Allowable loads may not be increased for short-term loading due to wind or seismic forces.
4. Mechanical and plumbing design codes may prescribe lower allowable loads. Verify with local codes.
5. Minimum concrete slab thickness = 2x embedment depth.

Metal-Deck Insert: Allowable Tension Loads in Normal-Weight or Sand-Lightweight Concrete over Metal Deck



Model No.	Drill Bit Dia. in.	Threaded Rod Dia. in.	Embed. Depth in. (mm)	Min. Edge Dist. in. (mm)	Min. Spacing in. (mm)	Tension Load Based on Concrete Strength (Install in High Flute)		Tension Load Based on Concrete Strength (Install in Low Flute)		Tension Load Based on Rod Strength
						$f'_c \geq 3,000$ psi (20.7 MPa)		$f'_c \geq 3,000$ psi (20.7 MPa)		F1554 Grade 36
						Ultimate lb. (kN)	Allowable lb. (kN)	Ultimate lb. (kN)	Allowable lb. (kN)	Allowable lb. (kN)
BBMD2550	1 3/16 – 7/8	1/4	2 (51)	7 1/2 (191)	8 (203)	9,320 (41.5)	2,330 (10.4)	3,210 (14.3)	800 (3.6)	940 (4.2)
		3/8								2,105 (9.4)
		1/2								3,750 (16.7)
BBMD3762	1 1/8 – 1 3/8	3/8	2 (51)	7 1/2 (191)	8 (203)	10,540 (46.9)	2,635 (11.7)	3,440 (15.3)	860 (3.8)	2,105 (9.4)
		1/2								3,750 (16.7)
		5/8								5,875 (26.1)
BBMD6275	1 3/16 – 1 3/8	5/8	2 (51)	7 1/2 (191)	8 (203)	12,360 (55.0)	3,090 (13.7)	3,445 (15.3)	860 (3.8)	5,875 (26.1)
		3/4								8,460 (37.6)

See notes under "Metal-Deck Insert: Shear Loads" on page 223.

* See page 12 for an explanation of the load table icons.

Blue Banger Hanger® Design Information — Concrete and Deck

Metal-Deck Insert: Allowable Shear Loads in Normal-Weight or Sand-Lightweight Concrete over Metal Deck



Model No.	Drill Bit Dia. in.	Threaded Rod Dia. in.	Embed. Depth in. (mm)	Min. Edge Dist. in. (mm)	Min. Spacing in. (mm)	Shear Load Based on Concrete Strength (Install in High Flute)		Shear Load Based on Concrete Strength (Install in Low Flute)		Shear Load Based on Rod Strength
						$f'_c \geq 3,000$ psi (20.7 MPa)		$f'_c \geq 3,000$ psi (20.7 MPa)		F1554 Grade 36
						Ultimate lb. (kN)	Allowable lb. (kN)	Ultimate lb. (kN)	Allowable lb. (kN)	Allowable lb. (kN)
BBMD2550	1 ⁹ / ₁₆ - 7 ⁸ / ₁₆	1/2	2 (51)	7 1/2 (191)	8 (203)	9,720 (43.2)	2,430 (10.8)	2,790 (12.4)	700 (3.1)	1,930 (8.6)
BBMD3762	1 1/8 - 1 3/8	5/8	2 (51)	7 1/2 (191)	8 (203)	9,400 (41.8)	2,350 (10.4)	3,360 (14.9)	840 (3.7)	3,025 (13.4)
BBMD6275	1 3/16 - 1 3/8	3/4	2 (51)	7 1/2 (191)	8 (203)	9,720 (43.2)	2,430 (10.8)	3,360 (14.9)	840 (3.7)	4,360 (19.4)

1. Allowable load must be the lesser of the concrete or rod strength.
2. The allowable loads based on concrete strength are based on a factor of safety of 4.0.
3. Allowable loads may not be increased for short-term loading due to wind or seismic forces.
4. Anchors may be installed off-center in the flute, up to 1" from the edge of flute.
5. Shear loads shall be applied flush with metal deck surface.
6. Deck shall be 20-gauge minimum.
7. Mechanical and plumbing design codes may prescribe lower allowable loads. Verify with local codes.
8. Installation must comply with Figure 1.

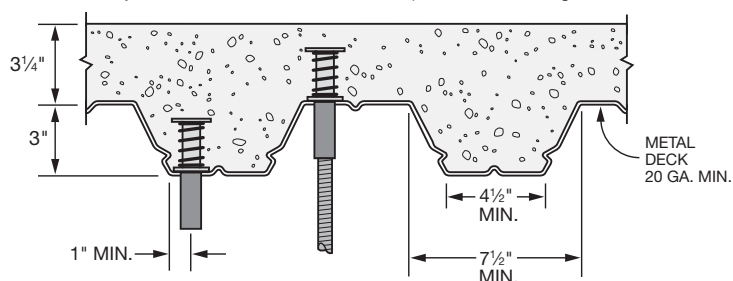

Figure 1.

Typical metal deck insert installation in concrete over metal deck

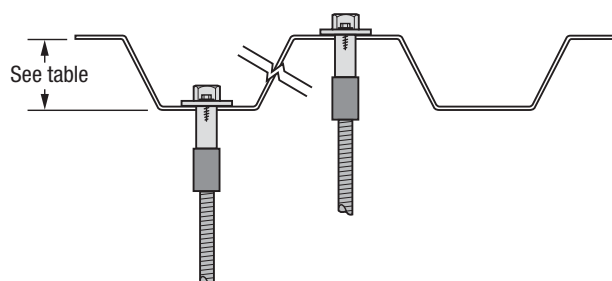

Figure 2.

Typical roof deck insert installation in metal deck

Roof-Deck Insert: Allowable Tension Loads in Metal Deck



Model No.	Drill Bit Dia. in.	Threaded Rod Dia. in.	Allowable Tension Based on Deck Strength Load lb. (kN)		Allowable Tension Load Based on Rod Strength lb. (kN)
			1 1/2" Deck	3" Deck	F1554 Grade 36
BBRD2550	1 ³ / ₁₆ - 7 ⁸ / ₁₆	1/4	150 (0.7)	300 (1.3)	940 (4.2)
		3/8			2,105 (9.4)
		1/2			3,750 (16.7)

1. The allowable loads are based on a factor of safety of 4.0.
2. Allowable loads may not be increased for short-term loading due to wind or seismic forces.
3. Acceptability of deck deflection due to imposed loads must be investigated separately.
4. Threaded rod strength must be investigated separately.
5. Anchors may be installed in the top or bottom flute of the metal deck.
6. Deck shall be 20-gauge minimum.
7. See Figure 2 for typical installation.

Wood-Form Insert: Factory Mutual and Underwriters Laboratories Pipe Size Limits

Model No.	Rod Dia. in.	FM Max. Nominal Pipe Size in.	UL Max. Nominal Pipe Size in.
BBWF2550	1/4	N/L	4
	3/8	4	4
	1/2	8	8
BBWF3762	3/8	4	4
	1/2	8	8
	5/8	N/L	8
BBWF6275	5/8	N/L	N/L
	3/4		

1. N/L = Not listed for this pipe size.

Metal-Deck Insert: Factory Mutual and Underwriters Laboratories Pipe Size Limits

Model No.	Rod Dia. in.	FM Max. Nominal Pipe Size		UL Max. Nominal Pipe Size	
		Install in High Flute in.	Install in Low Flute in.	Install in High Flute in.	Install in Low Flute in.
BBMD2550	1/4	N/L	N/L	4	4
	3/8	4	4	4	4
	1/2	8	N/L	8	4
BBMD3762	3/8	4	4	4	4
	1/2	8	N/L	8	4
	5/8	N/L	N/L	8	4
BBMD6275	5/8	12	N/L	12	N/L
	3/4	12	N/L	12	N/L

1. N/L = Not listed for this pipe size.

* See page 12 for an explanation of the load table icons.

Drop-In Internally Threaded Anchor (DIAB)

Expansion shell anchors for use in solid base materials

Simpson Strong-Tie introduces a new, redesigned Drop-In Anchor (DIAB) that provides easier installation into base materials. Improved geometry in the preassembled expansion plug improves setting capability so the anchor installs with 40% fewer hammer strikes than previous versions. These displacement-controlled expansion anchors are easily set by driving the plug toward the bottom of the anchor using either the hand- or power-setting tools. DIAB anchors feature a positive-set marking indicator at the top of the anchor — helping you see more clearly when proper installation has taken place.

Use a Simpson Strong-Tie fixed-depth stop bit to take the guesswork out of drilling to the correct depth. The fluted design of the tip draws debris away from the hole during drilling, allowing for a cleaner installation.

Key features

- New design offers easier installation than previous drop-in anchor design – sets with 40% fewer hammer hits
- Positive-set marking system indicates when anchor is properly set
- Lipped drop-in version available for flush installation
- Hand- and power-setting tools available for fast, easy and economical installation
- Fixed-depth stop bit helps you drill to the correct depth every time



Material: Carbon steel

Coating: Zinc plated



Drop-In



Lipped Drop-In



Anchor being set with hand setting tool.



Anchor being set with SDS setting tool.



Positive set indicator.

Drop-In Internally Threaded Anchor (DIAB)

Drop-In Anchor

Rod Size (in.)	Model No.	Drill Bit Dia. (in.)	Bolt Threads (per in.)	Body Length (in.)	Thread Length (in.)	Quantity	
						Box	Carton
¼	DIAB25	⅜	20	1	⅜	100	500
⅜	DIAB37	½	16	1⅞	⅝	50	250
½	DIAB50	⅝	13	2	¾	50	200
⅝	DIAB62	⅞	11	2½	1	25	100
¾	DIAB75	1	10	3⅞	1¼	20	80



Drop-In

Lipped Drop-In Anchor

Rod Size (in.)	Model No.	Drill Bit Dia. (in.)	Bolt Threads (per in.)	Body Length (in.)	Thread Length (in.)	Quantity	
						Box	Carton
¼	DIABL25	⅜	20	1	⅜	100	500
⅜	DIABL37	½	16	1⅞	⅝	50	250
½	DIABL50	⅝	13	2	¾	50	200



Lipped Drop-In

Drop-In Anchor Hand Setting Tool

Model No.	For Use With	Box Quantity
DIABST25	DIAB25, DIABL25	10
DIABST37	DIAB37, DIABL37	10
DIABST50	DIAB50, DIABL50	10
DIABST62	DIAB62	5
DIABST75	DIAB75	5

1. Setting tools sold separately, Tools may be ordered by the piece.



Hand Setting Tool

Drop-In Anchor Power Setting Tool

Model No.	For Use With	Box Quantity
DIABST25-SDS	DIAB25, DIABL25	10
DIABST37-SDS	DIAB37, DIABL37	10
DIABST50-SDS	DIAB50, DIABL50	10



Power Setting Tool

Fixed-Depth Drill Bits

Model No.	Drill Bit Diameter (in.)	Drill Depth (In.)	For Use With
MDPL037DIA	⅜	1⅞	DIAB25, DIABL25
MDPL050DIA	½	1⅞	DIAB37, DIABL37
MDPL062DIA	⅝	2⅞	DIAB50, DIABL50



Fixed-Depth Drill Bit

Drop-In Internally Threaded Anchor (DIAB)

DIAB Manual Installation

⚠ Caution: Oversized holes will reduce the anchors load capacity

1. Drill a hole in the base material using the appropriate diameter carbide drill bit or fixed depth bit as specified in the table. Drill the hole to the specified embedment. For fixed depth bits drill the hole until the shoulder of the bit contacts the surface of the base material. Then blow the hole clean of dust and debris using compressed air. Overhead installations need not be blown clean.
2. Insert the anchor into the hole. Tap with hammer until flush against the surface.
3. Using the designated Drop-In setting tool, drive expander plug towards the bottom of the anchor until the shoulder of the setting tool makes contact with the top of the anchor. When properly set 4 indentations will be visible on the top of the anchor indicating full expansion.
4. Insert bolt or threaded rod. Minimum thread engagement should be equal to the nominal diameter of the threaded insert.

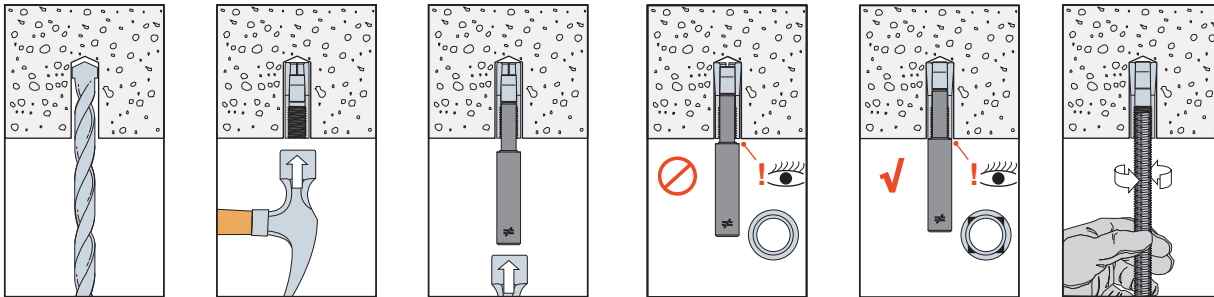

DIAB SDS Installation

⚠ Caution: Oversized holes will reduce the anchors load capacity

1. Drill a hole in the base material using the appropriate diameter carbide drill bit or fixed depth drill bit as specified in the table. Drill the hole to the specified embedment. For fixed depth bits drill the hole until the shoulder of the bit contacts the surface of the base material. Then blow the hole clean of dust and debris using compressed air. Overhead installations need not be blown clean.
2. Insert the anchor into the hole. Tap with hammer until flush against the surface.
3. Attach SDS Drop-In setting tool a drill. Drive expander plug towards the bottom of the anchor using only hammer mode until the shoulder of the setting tool makes contact with the top of the anchor. When properly set 4 indentations will be visible on the top of the anchor indicating full expansion.
4. Insert bolt or threaded rod. Minimum thread engagement should be equal to the nominal diameter of the threaded insert.

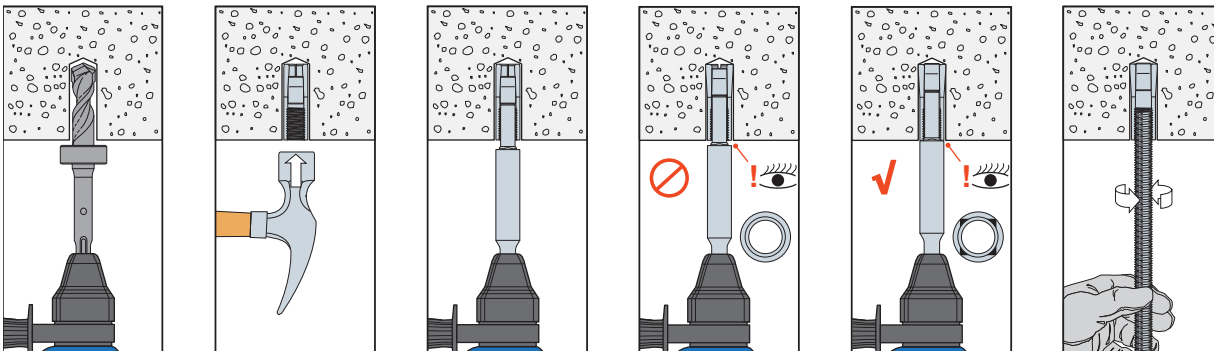

Drop-In (DIAB) Design Information — Concrete



DIAB Allowable Tension and Shear Loads in Normal-Weight Concrete

Model No.	Rod Size in. (mm)	Drill Bit Dia. In.	Embed Depth In. (mm)	Critical Edge Dist. In. (mm)	Critical Spacing In. (mm)	$f'_c \geq 2,500$ psi (17.2 MPa)				$f'_c \geq 4,000$ psi (27.6 MPa)			
						Tension Load		Shear Load		Tension Load		Shear Load	
						Ultimate lb. (kN)	Allowable lb. (kN)	Ultimate lb. (kN)	Allowable lb. (kN)	Ultimate lb. (kN)	Allowable lb. (kN)	Ultimate lb. (kN)	Allowable lb. (kN)
DIAB25 DIABL25	¼ (6.4)	⅜	1 (25)	3 (76)	4 (102)	1,565 (7.0)	390 (1.7)	1,840 (8.2)	460 (2.0)	1,965 (8.7)	490 (2.2)	1,840 (8.2)	460 (2.0)
DIAB37 DIABL37	⅜ (9.5)	½	1⅞ (40)	4½ (114)	6 (152)	2,950 (13.1)	740 (3.3)	4,775 (21.2)	1,195 (5.3)	3,910 (17.4)	980 (4.4)	4,775 (21.2)	1,195 (5.3)
DIAB50 DIABL50	½ (12.7)	⅝	2 (51)	6 (152)	8 (203)	5,190 (23.1)	1,300 (5.8)	6,760 (30.1)	1,690 (7.5)	6,515 (29.0)	1,630 (7.3)	6,760 (30.1)	1,690 (7.5)
DIAB62	⅝ (15.9)	⅞	2½ (64)	7½ (191)	10 (254)	7,010 (31.2)	1,755 (7.8)	12,190 (54.2)	3,050 (13.6)	9,060 (40.3)	2,265 (10.1)	12,190 (54.2)	3,050 (13.6)
DIAB75	¾ (19.1)	1	3⅞ (79)	9 (229)	12½ (318)	9,485 (42.2)	2,370 (10.5)	15,960 (71.0)	3,990 (17.7)	11,660 (51.9)	2,915 (13.0)	15,960 (71.0)	3,990 (17.7)

1. The allowable loads listed are based on a safety factor of 4.0.
2. Refer to allowable load-adjustment factors for edge distance and spacing on page 228.
3. Allowable loads may be linearly interpolated between concrete strength listed.
4. The minimum concrete thickness is 1 ½ times the embedment depth.
5. Allowable loads may not be increased for short-term loading due to wind or seismic forces.

DIAB Allowable Tension and Shear Loads in Soffit of Sand-Lightweight Concrete over Metal Deck

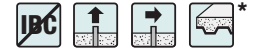

Model No.	Rod Size in. (mm)	Drill Bit Dia. In.	Embed Depth In. (mm)	Critical End Dist. ⁶ In. (mm)	Critical Spacing In. (mm)	$f'_c \geq 3,000$ psi (20.7 MPa)			
						Tension Load		Shear Load	
						Ultimate lb. (kN)	Allowable lb. (kN)	Ultimate lb. (kN)	Allowable lb. (kN)
DIAB37 DIABL37	⅜ (9.5)	½	1⅞ (40)	4½ (114)	6 (152)	2,895 (12.9)	725 (3.2)	3,530 (15.7)	885 (3.9)
DIAB50 DIABL50	½ (12.7)	⅝	2 (51)	6 (152)	8 (203)	4,100 (18.2)	1,025 (4.6)	4,685 (20.8)	1,170 (5.2)

1. The allowable loads listed are based on a safety factor of 4.0.
2. Allowable loads may not be increased for short-term loading due to wind or seismic forces.
3. Refer to allowable load-adjustment factors for edge distance and spacing on page 228.
4. Anchors were installed in the center of the bottom flute of the steel deck.
5. Metal deck must be minimum 20-gauge thick with minimum yield strength of 33 ksi.
6. Critical end distance is defined as the distance from end of the slab in the direction of the flute.

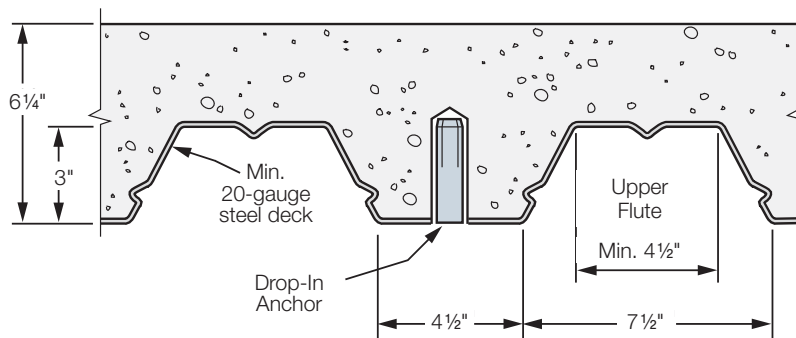

Lightweight Concrete over Metal Deck

* See page 12 for an explanation of the load table icons.

Drop-In (DIAB) Design Information — Concrete

Allowable Load-Adjustment Factors for Drop-In Anchor (DIAB) in Normal-Weight Concrete and Sand-Lightweight Concrete over Metal Deck: Edge Distance and Spacing, Tension and Shear Loads

How to use these charts:

- The following tables are for reduced edge distance and spacing.
- Locate the anchor size to be used for either a tension and/or a shear load application.
- Locate the edge distance (C_{act}) or spacing (S_{act}) at which the anchor is to be installed.

- The load adjustment factor (f_c or f_s) is the intersection of the row and column.
- Multiply the allowable load by the applicable load adjustment factor.
- Reduction factors for multiple edges or spacing are multiplied together.

Edge Distance Tension (f_c)

Edge Dist. C_{act} (in.)	Size	1/4	3/8	1/2	5/8	3/4
		C_{cr}	3	4 1/2	6	7 1/2
	C_{min}	1 3/4	2 5/8	3 1/2	4 3/8	5 1/4
	f_{cmin}	0.77	0.77	0.77	0.77	0.77
1 3/4		0.77				
2		0.82				
2 1/2		0.91				
2 5/8		0.93	0.77			
3		1.00	0.82			
3 1/2			0.88	0.77		
4			0.94	0.82		
4 3/8			0.98	0.85	0.77	
4 1/2			1.00	0.86	0.78	
5				0.91	0.82	
5 1/4				0.93	0.83	0.77
5 1/2				0.95	0.85	0.79
6				1.00	0.89	0.82
6 1/2					0.93	0.85
7					0.96	0.88
7 1/2					1.00	0.91
8						0.94
8 1/2						0.97
9						1.00



- C_{act} = actual edge distance at which anchor is installed (inches).
- C_{cr} = critical edge distance for 100% load (inches).
- C_{min} = minimum edge distance for reduced load (inches).
- f_c = adjustment factor for allowable load at actual edge distance.
- f_{ocr} = adjustment factor for allowable load at critical edge distance. f_{ocr} is always = 1.00.
- f_{cmin} = adjustment factor for allowable load at minimum edge distance.
- $f_c = f_{cmin} + [(1 - f_{cmin})(C_{act} - C_{min}) / (C_{cr} - C_{min})]$.

Edge Distance Shear (f_c)

Edge Dist. C_{act} (in.)	Size	1/4	3/8	1/2	5/8	3/4
		C_{cr}	3	4 1/2	6	7 1/2
	C_{min}	1 3/4	2 5/8	3 1/2	4 3/8	5 1/4
	f_{cmin}	0.54	0.54	0.64	0.64	0.64
1 3/4		0.54				
2		0.63				
2 1/2		0.82				
2 5/8		0.86	0.54			
3		1.00	0.63			
3 1/2			0.75	0.64		
4			0.88	0.71		
4 3/8			0.97	0.77	0.64	
4 1/2			1.00	0.78	0.65	
5				0.86	0.71	
5 1/4				0.89	0.74	0.64
5 1/2				0.93	0.77	0.66
6				1.00	0.83	0.71
6 1/2					0.88	0.76
7					0.94	0.81
7 1/2					1.00	0.86
8						0.90
8 1/2						0.95
9						1.00



- C_{act} = actual edge distance at which anchor is installed (inches).
- C_{cr} = critical edge distance for 100% load (inches).
- C_{min} = minimum edge distance for reduced load (inches).
- f_c = adjustment factor for allowable load at actual edge distance.
- f_{ocr} = adjustment factor for allowable load at critical edge distance. f_{ocr} is always = 1.00.
- f_{cmin} = adjustment factor for allowable load at minimum edge distance.
- $f_c = f_{cmin} + [(1 - f_{cmin})(C_{act} - C_{min}) / (C_{cr} - C_{min})]$.

Spacing Tension (f_s)

Spacing S_{act} (in.)	Size	1/4	3/8	1/2	5/8	3/4
		S_{cr}	4	6	8	10
	S_{min}	1 1/2	2 1/4	3	3 3/4	4 3/4
	f_{smin}	0.72	0.72	0.80	0.80	0.80
1 1/2		0.72				
2		0.78				
2 1/4		0.80	0.72			
2 1/2		0.83	0.74			
3		0.89	0.78	0.80		
3 1/2		0.94	0.81	0.82		
3 3/4		0.97	0.83	0.83	0.80	
4		1.00	0.85	0.84	0.81	
4 1/2			0.89	0.86	0.82	
4 3/4			0.91	0.87	0.83	0.80
5			0.93	0.88	0.84	0.81
5 1/2			0.96	0.90	0.86	0.82
6			1.00	0.92	0.87	0.83
6 1/2				0.94	0.89	0.85
7				0.96	0.90	0.86
7 1/2				0.98	0.92	0.87
8				1.00	0.94	0.88
8 1/2					0.95	0.90
9					0.97	0.91
9 1/2					0.98	0.92
10					1.00	0.94
10 1/2						0.95
11						0.96
11 1/2						0.97
12						0.99
12 1/2						1.00



- S_{act} = actual spacing distance at which anchor is installed (inches).
- S_{cr} = critical spacing distance for 100% load (inches).
- S_{min} = minimum spacing distance for reduced load (inches).
- f_s = adjustment factor for allowable load at actual spacing distance.
- f_{ocr} = adjustment factor for allowable load at critical spacing distance. f_{ocr} is always = 1.00.
- f_{smin} = adjustment factor for allowable load at minimum spacing distance.
- $f_s = f_{smin} + [(1 - f_{smin})(S_{act} - S_{min}) / (S_{cr} - S_{min})]$.

Spacing Shear (f_s)

Spacing S_{act} (in.)	Size	1/4	3/8	1/2	5/8	3/4
		S_{cr}	4	6	8	10
	S_{min}	1 1/2	2 1/4	3	3 3/4	4 3/4
	f_{smin}	1.00	1.00	1.00	1.00	1.00
1 1/2		1.00				
2		1.00				
2 1/4		1.00	1.00			
2 1/2		1.00	1.00			
3		1.00	1.00	1.00		
3 1/2		1.00	1.00	1.00		
3 3/4		1.00	1.00	1.00	1.00	
4		1.00	1.00	1.00	1.00	
4 1/2			1.00	1.00	1.00	
4 3/4			1.00	1.00	1.00	1.00
5			1.00	1.00	1.00	1.00
5 1/2			1.00	1.00	1.00	1.00
6			1.00	1.00	1.00	1.00
6 1/2				1.00	1.00	1.00
7				1.00	1.00	1.00
7 1/2				1.00	1.00	1.00
8				1.00	1.00	1.00
8 1/2					1.00	1.00
9					1.00	1.00
9 1/2					1.00	1.00
10					1.00	1.00
10 1/2						1.00
11						1.00
11 1/2						1.00
12						1.00
12 1/2						1.00



- S_{act} = actual spacing distance at which anchor is installed (inches).
- S_{cr} = critical spacing distance for 100% load (inches).
- S_{min} = minimum spacing distance for reduced load (inches).
- f_s = adjustment factor for allowable load at actual spacing distance.
- f_{ocr} = adjustment factor for allowable load at critical spacing distance. f_{ocr} is always = 1.00.
- f_{smin} = adjustment factor for allowable load at minimum spacing distance.
- $f_s = f_{smin} + [(1 - f_{smin})(S_{act} - S_{min}) / (S_{cr} - S_{min})]$.

* See page 12 for an explanation of the load table icons.

Drop-In Internally Threaded Anchor (DIA)

Drop-in anchors are internally threaded drop-in expansion anchors for use in flush-mount applications in solid base materials. Available in stainless steel (DIA), short (DIAS) or coil-thread (DIAC) versions. Minimum thread engagement should be equal to the nominal diameter of the threaded insert.

Features

- Lipped edge (DIAS) eliminates need for precisely drilled hole depth
- Available in coil-thread version for 1/2" and 3/4" coil-threaded rod
- Short length (DIAS) enables shallow embedment to help avoid drilling into rebar or pre-stressed/post-tensioned cables
- Short Drop-In anchors include a setting tool compatible with the anchor to ensure consistent installation

Material: Carbon and stainless steel

Coating: Carbon steel; zinc plated

Codes: Drop-in: DOT; Factory Mutual 3017082; Underwriters Laboratories File Ex3605. Meets requirements of Federal Specifications A-A-55614, Type I.

Short drop-in: Factory Mutual 3017082 and Underwriters Laboratories File Ex3605.



Caution: The load tables list values based upon results from the most recent testing and may not reflect those in current code reports. Where code jurisdictions apply, consult the current reports for applicable load values.

Installation

1. Drill a hole in the base material using the appropriate diameter carbide drill bit as specified in the table. Drill the hole to the specified embedment depth plus 1/8" for flush mounting. Blow the hole clean using compressed air. Overhead installations need not be blown clean.
2. Insert designated anchor into hole. Tap with hammer until flush against surface.
3. Using the designated drop-in setting tool, drive expander plug toward the bottom of the anchor until shoulder of setting tool makes contact with the top of the anchor.
4. Minimum thread engagement should be equal to the nominal diameter of the threaded insert.



Caution: Oversized holes will make it difficult to set the anchor and will reduce the anchor's load capacity.



**Drop-In
Stainless
Steel**



**Short
Drop-In**



**Coil-Thread
Drop-In**

Installation Sequence

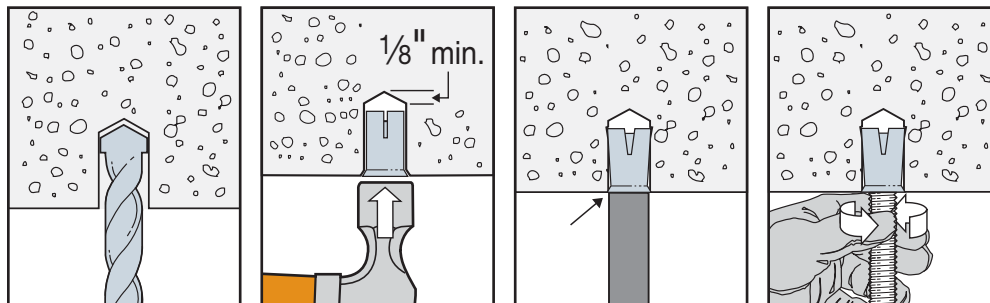

Drop-In Internally Threaded Anchor (DIA)

Drop-In Anchor Product Data – Stainless Steel

Rod Size (in.)	Type 303/304 Stainless Model No.	Type 316 Stainless Model No.	Drill Bit Dia. (in.)	Bolt Threads (per in.)	Body Length (in.)	Thread Length (in.)	Quantity	
							Box	Carton
¼	DIA25SS	DIA256SS	¾	20	1	¾	100	500
⅜	DIA37SS	DIA376SS	½	16	1 ⅞	¾	50	250
½	DIA50SS	DIA506SS	⅝	13	2	¾	50	200
⅝	DIA62SS	—	⅞	11	2 ½	1	25	100
¾	DIA75SS	—	1	10	3 ⅞	1 ¼	20	80

Short Drop-In Anchor Product Data

Rod Size (in.)	Model No.	Drill Bit Diameter (in.)	Bolt Threads (per in.)	Body Length (in.)	Thread Length (in.)	Quantity	
						Box	Carton
⅜	DIA37S ¹	½	16	¾	¼	100	500
½	DIA50S ¹	⅝	13	1	⅝	50	200

1. A dedicated setting tool is included with each box of DIA37S and DIA50S.

Coil-Thread Drop-In Anchor Product Data

Rod Size (in.)	Carbon Steel Model No.	Drill Bit Diameter (in.)	Bolt Threads (per in.)	Body Length (in.)	Thread Length (in.)	Quantity	
						Box	Ctn.
½	DIA50C ¹	⅝	6	2	¾	50	200
¾	DIA75C ¹	1	5	3 ⅞	1 ¼	20	80

1. DIA50C and DIA75C accept ½" and ¾" coil-thread rod, respectively.

Drop-In Anchor Setting Tool Product Data

Model No.	For Use With	Box Qty.
DIAS25	DIA25SS, DIA256SS	10
DIAS37	DIA37SS, DIA376SS	10
DIAS50	DIA50SS, DIA506SS, DIA50C	10
DIAS62	DIA62SS	5
DIAS75	DIA75SS, DIA75C	5

- Setting tools sold separately except for DIA37S and DIA50S.
- Setting tools for use with carbon and stainless-steel drop-in anchors.
- Setting tools may be ordered by the piece.



Drop-In Anchor Setting Tool



Power Setting Tool

Drop-In Anchor (DIA) Power Setting Tool

Model No.	For Use With	Box Qty.
DIAS37S-SDS	DIA37S	10
DIAS50S-SDS	DIA50S	10

Also sold by the piece

Drop-In Anchor Stop Bit

Model No.	Drill Bit Diameter (in.)	Drop-In Anchor (in.)	Drill Depth (in.)
MDPL037DIA	¾	¼	1 ⅞
MDPL050DIA	½	¾	1 ⅞
MDPL062DIA	½	½	1 ⅞
MDPL050DIAS	⅝	¾	1 ⅞
MDPL062DIAS	⅝	½	2 ⅞



Stop Bit

Drop-In (DIA) Design Information — Concrete

Allowable Tension Loads for Drop-In (Stainless Steel) and Coil-Thread Drop-In (Carbon Steel) Anchors in Normal-Weight Concrete



Rod Size in. (mm)	Drill Bit Dia. in.	Embed. Depth in. (mm)	Critical Edge Dist. in. (mm)	Critical Spacing in. (mm)	Tension Load							
					$f'_c \geq 2,000$ psi (13.8 MPa) Concrete			$f'_c \geq 3,000$ psi (20.7 MPa) Concrete		$f'_c \geq 4,000$ psi (27.6 MPa) Concrete		
					Ultimate lb. (kN)	Std. Dev. lb. (kN)	Allowable lb. (kN)	Allowable lb. (kN)	Ultimate lb. (kN)	Std. Dev. lb. (kN)	Allowable lb. (kN)	
¼ (6.4)	⅜	1 (25)	3 (76)	4 (102)	1,400 (6.2)	201 (0.9)	350 (1.6)	405 (1.8)	1,840 (8.2)	451 (2.0)	460 (2.0)	
⅜ (9.5)	½	1⅞ (40)	4½ (114)	6 (152)	2,400 (10.7)	251 (1.1)	600 (2.7)	795 (3.5)	3,960 (17.6)	367 (1.6)	990 (4.4)	
½ (12.7)	⅝	2 (51)	6 (152)	8 (203)	3,320 (14.8)	372 (1.7)	830 (3.7)	1,178 (5.2)	6,100 (27.1)	422 (1.9)	1,525 (6.8)	
⅝ (15.9)	⅞	2½ (64)	7½ (191)	10 (254)	5,040 (22.4)	689 (3.1)	1,260 (5.6)	1,715 (7.6)	8,680 (38.6)	971 (4.3)	2,170 (9.7)	
¾ (19.1)	1	3⅞ (79)	9 (229)	12½ (318)	8,160 (36.3)	961 (4.3)	2,040 (9.1)	2,365 (10.5)	10,760 (47.9)	1,696 (7.5)	2,690 (12.0)	

1. The allowable loads listed are based on a safety factor of 4.0.
2. Refer to allowable load-adjustment factors for edge distance and spacing on page 234.
3. Allowable loads may be linearly interpolated between concrete strengths listed.
4. The minimum concrete thickness is 1½ times the embedment depth.

Allowable Shear Loads for Drop-In (Stainless Steel) and Coil-Thread Drop-In (Carbon Steel) Anchors in Normal-Weight Concrete



Rod Size in. (mm)	Drill Bit Dia. in.	Embed. Depth in. (mm)	Critical Edge Dist. in. (mm)	Critical Spacing in. (mm)	Shear Load					
					$f'_c \geq 2,000$ psi (13.8 MPa) Concrete			$f'_c \geq 3,000$ psi (20.7 MPa) Concrete		$f'_c \geq 4,000$ psi (27.6 MPa) Concrete
					Ultimate lb. (kN)	Std. Dev. lb. (kN)	Allowable lb. (kN)	Allowable lb. (kN)	Allowable lb. (kN)	
¼ (6.4)	⅜	1 (25)	3½ (89)	4 (102)	1,960 (8.7)	178 (0.8)	490 (2.2)	490 (2.2)	490 (2.2)	
⅜ (9.5)	½	1⅞ (40)	5¼ (133)	6 (152)	3,240 (14.4)	351 (1.6)	810 (3.6)	925 (4.1)	1,040 (4.6)	
½ (12.7)	⅝	2 (51)	7 (178)	8 (203)	7,000 (31.1)	562 (2.5)	1,750 (7.8)	1,750 (7.8)	1,750 (7.8)	
⅝ (15.9)	⅞	2½ (64)	8¾ (222)	10 (254)	11,080 (49.3)	923 (4.1)	2,770 (12.3)	2,770 (12.3)	2,770 (12.3)	
¾ (19.1)	1	3⅞ (79)	10½ (267)	12½ (318)	13,800 (61.4)	1,781 (7.9)	3,450 (15.3)	3,725 (16.6)	4,000 (17.8)	

1. The allowable loads listed are based on a safety factor of 4.0.
2. Refer to allowable load-adjustment factors for edge distance and spacing on page 234.
3. Allowable loads may be linearly interpolated between concrete strengths listed.
4. The minimum concrete thickness is 1½ times the embedment depth.

Material Specifications

Anchor Component	Component Material		
	Zinc Plated Carbon Steel	Type 303/304 Stainless Steel	Type 316 Stainless Steel
Anchor Body	Meets minimum 70,000 psi tensile	AISI 303. Meets chemical requirements of ASTM A582	Type 316
Expander Plug	Meets minimum 50,000 psi tensile	AISI 303	Type 316
Thread	UNC/Coil-thread	UNC	UNC

Note: DIA37S, DIA50C and DIA75C are not available in stainless steel.

* See page 12 for an explanation of the load table icons.

Drop-In (DIA) Design Information — Concrete

Allowable Tension and Shear Loads for 3/8" and 1/2" Short Drop-In Anchor in Sand-Lightweight Concrete Fill over Metal Deck

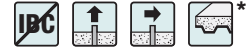

Model No.	Rod Size (in.)	Drill Bit Dia. (in.)	Emb. Depth (in.)	Tension Critical End Distance (in.)	Shear Critical End Distance (in.)	Critical Spacing (in.)	Install through the Lower Flute or Upper Flute of Metal Deck, $f'_c \geq 3,000$ psi Concrete (20.7 MPa)			
							Tension Load		Shear Load	
							Ultimate (lb.)	Allowable (lb.)	Ultimate (lb.)	Allowable (lb.)
DIA37S	3/8	1/2	3/4	6	7	8	1,344	335	1,649	410
DIA50S	1/2	5/8	1	8	9 3/8	10 3/8	1,711	430	2,070	515

1. The allowable loads listed are based on a safety factor of 4.0.
2. Allowable loads may not be increased for short-term loading due to wind or seismic forces.
3. Refer to allowable load-adjustment factors for edge distances and spacing on page 235.
4. Anchors were installed with a 1" offset from the centerline of the flute.

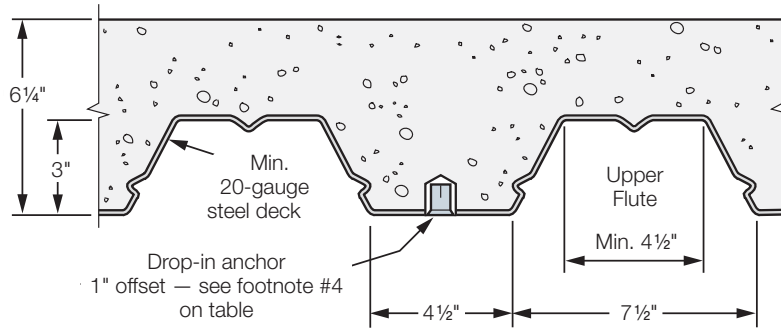

Lightweight Concrete over Metal Deck

* See page 12 for an explanation of the load table icons.

Drop-In (DIA) Design Information — Concrete

Allowable Tension and Shear Loads for 3/8" and 1/2" Short Drop-In Anchor in Normal-Weight Concrete

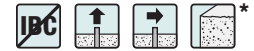

Model No.	Rod Size (in.)	Drill Bit Dia. (in.)	Emb. Depth (in.)	Tension Critical Edge Distance (in.)	Shear Critical Edge Distance (in.)	Critical Spacing (in.)	Normal-Weight Concrete, $f'_c \geq 2500$ psi				Normal-Weight Concrete, $f'_c \geq 4,000$ psi			
							Tension Load		Shear Load		Tension Load		Shear Load	
							Ultimate (lb.)	Allowable (lb.)	Ultimate (lb.)	Allowable (lb.)	Ultimate (lb.)	Allowable (lb.)	Ultimate (lb.)	Allowable (lb.)
DIA37S	3/8	1/2	3/4	4 1/2	5 1/4	3	1,500	375	2,274	570	2,170	540	3,482	870
DIA50S	1/2	5/8	1	6	7	4	2,039	510	3,224	805	3,420	855	5,173	1,295

1. The allowable loads listed are based on a safety factor of 4.0.
2. Allowable loads may not be increased for short-term loading due to wind or seismic forces.
3. Refer to allowable load-adjustment factors for edge distances and spacing on page 234.
4. Allowable loads may be linearly interpolated between concrete strengths.
5. The minimum concrete thickness is 1 1/2 times the embedment depth.

Allowable Tension and Shear Loads for 3/8" and 1/2" Short Drop-In Anchor in Hollow-Core Concrete Panel

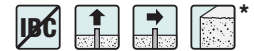

Model No.	Rod Size (in.)	Drill Bit Dia. (in.)	Emb. Depth (in.)	Tension Critical Edge Distance (in.)	Shear Critical Edge Distance (in.)	Critical Spacing (in.)	Hollow Core Concrete Panel, $f'_c \geq 4,000$ psi			
							Tension Load		Shear Load	
							Ultimate (lb.)	Allowable (lb.)	Ultimate (lb.)	Allowable (lb.)
DIA37S	3/8	1/2	3/4	4 1/2	5 1/4	3	1,860	465	3,308	825
DIA50S	1/2	5/8	1	6	7	4	2,650	660	4,950	1,235

1. The allowable loads listed are based on a safety factor of 4.0.
2. Allowable loads may not be increased for short-term loading due to wind or seismic forces.
3. Refer to allowable load-adjustment factors for edge distances and spacing on page 234.
4. Allowable loads may be linearly interpolated between concrete strengths.

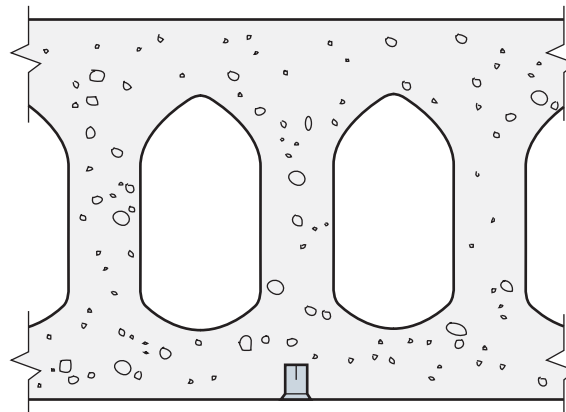

Hollow-Core Concrete Panel
(Anchor can be installed below web or hollow core)

* See page 12 for an explanation of the load table icons.

Drop-In (DIA) Design Information — Concrete

Allowable Load-Adjustment Factors for Drop-In (Stainless Steel), Coil Thread (Carbon Steel) and Short Drop-In Anchors in Normal-Weight Concrete: Edge Distance and Spacing, Tension and Shear Loads

How to use these charts:

1. The following tables are for reduced edge distance and spacing.
2. Locate the anchor size to be used for either a tension and/or shear load application.
3. Locate the edge distance (c_{act}) or spacing (s_{act}) at which the anchor is to be installed.
4. The load adjustment factor (f_c or f_s) is the intersection of the row and column.
5. Multiply the allowable load by the applicable load adjustment factor.
6. Reduction factors for multiple edges or spacing are multiplied together.

Edge Distance Tension (f_c)

Edge Dist. c_{act} (in.)	Size	1/4	3/8	1/2	5/8	3/4
	c_{cr}	3	4 1/2	6	7 1/2	9
	c_{min}	1 3/4	2 5/8	3 1/2	4 3/8	5 1/4
	f_{cmin}	0.65	0.65	0.65	0.65	0.65
1 3/4		0.65				
2		0.72				
2 1/2		0.86				
2 5/8		0.90	0.65			
3		1.00	0.72			
3 1/2			0.81	0.65		
4			0.91	0.72		
4 3/8			0.98	0.77	0.65	
4 1/2			1.00	0.79	0.66	
5				0.86	0.72	
5 1/4				0.90	0.75	0.65
5 1/2				0.93	0.78	0.67
6				1.00	0.83	0.72
6 1/2					0.89	0.77
7					0.94	0.81
7 1/2					1.00	0.86
8						0.91
8 1/2						0.95
9						1.00

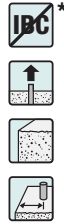

Spacing Tension and Shear (f_s)

s_{act} (in.)	Size	1/4	3/8 ⁹	1/2	5/8	3/4
	E	1	3/4	1 1/2	1	2
	s_{cr}	4	3	6	4	8
	s_{min}	2	1 1/2	3	2	4
	f_{smin}	0.50	0.50	0.50	0.50	0.50
1 1/2			0.50			
2		0.50	0.67		0.50	
2 1/2		0.63	0.83		0.63	
3		0.75	1.00	0.50	0.75	
3 1/2		0.88		0.58	0.88	
4		1.00		0.67	1.00	0.50
4 1/2				0.75		0.56
5				0.83		0.63
5 1/2				0.92		0.69
6				1.00		0.75
6 1/4					0.78	0.63
7					0.88	0.70
8					1.00	0.80
9						0.90
10						1.00
11						0.88
12						0.96
12 1/2						1.00



See notes below.

Edge Distance Shear (f_c)

Edge Dist. c_{act} (in.)	Size	1/4	3/8	1/2	5/8	3/4
	c_{cr}	3 1/2	5 1/4	7	8 3/4	10 1/2
	c_{min}	1 3/4	2 5/8	3 1/2	4 3/8	5 1/4
	f_{cmin}	0.45	0.45	0.45	0.45	0.45
1 3/4		0.45				
2		0.53				
2 1/2		0.69				
2 5/8		0.73	0.45			
3		0.84	0.53			
3 1/2		1.00	0.63	0.45		
4			0.74	0.53		
4 3/8			0.82	0.59	0.45	
4 1/2			0.84	0.61	0.47	
5			0.95	0.69	0.53	
5 1/4			1.00	0.73	0.56	0.45
5 1/2				0.76	0.59	0.48
6				0.84	0.65	0.53
6 1/2				0.92	0.72	0.58
7				1.00	0.78	0.63
7 1/2					0.84	0.69
8					0.91	0.74
8 1/2					0.97	0.79
8 3/4					1.00	0.82
9						0.84
9 1/2						0.90
10						0.95
10 1/2						1.00

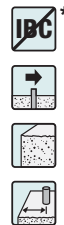

1. E = Embedment depth (inches).
2. s_{act} = actual spacing distance at which anchors are installed (inches).
3. s_{cr} = critical spacing distance for 100% load (inches).
4. s_{min} = minimum spacing distance for reduced load (inches).
5. f_s = adjustment factor for allowable load at actual spacing distance.
6. f_{scr} = adjustment factor for allowable load at critical spacing distance. f_{scr} is always = 1.00.
7. f_{smin} = adjustment factor for allowable load at minimum spacing distance.
8. $f_s = f_{smin} + [(1 - f_{smin})(s_{act} - s_{min}) / (s_{cr} - s_{min})]$.
9. 3/8" short drop-in (DIA37S).
10. 1/2" short Drop-in (DIA50S)

1. c_{act} = actual edge distance at which anchor is installed (inches).
2. c_{cr} = critical edge distance for 100% load (inches).
3. c_{min} = minimum edge distance for reduced load (inches).
4. f_c = adjustment factor for allowable load at actual edge distance.
5. f_{ccr} = adjustment factor for allowable load at critical edge distance. f_{ccr} is always = 1.00.
6. f_{cmin} = adjustment factor for allowable load at minimum edge distance.
7. $f_c = f_{cmin} + [(1 - f_{cmin})(c_{act} - c_{min}) / (c_{cr} - c_{min})]$.

* See page 12 for an explanation of the load table icons.

Drop-In (DIA) Design Information — Concrete

Allowable Load-Adjustment Factors for Short Drop-in Anchors in Sand-Lightweight Concrete over Metal Deck: Edge Distance and Spacing, Tension and Shear Loads

How to use these charts:

1. The following tables are for reduced edge distance and spacing.
2. Locate the anchor size to be used for either a tension and/or shear load application.
3. Locate the edge distance (c_{act}) or spacing (s_{act}) at which the anchor is to be installed.
4. The load adjustment factor (f_c or f_s) is the intersection of the row and column.
5. Multiply the allowable load by the applicable load adjustment factor.
6. Reduction factors for multiple edges or spacing are multiplied together.

Edge Distance Tension (f_c)

Edge Dist. c_{act} (in.)	Size	¾	½
	c_{cr}	6	8
	c_{min}	3½	4¾
	f_{cmin}	0.65	0.65
3½		0.65	
4		0.72	
4½		0.79	
4¾		0.83	0.65
5		0.86	0.68
5½		0.93	0.73
6		1.00	0.78
6½			0.84
7			0.89
7½			0.95
8			1.00



See notes below.

Spacing Tension and Shear (f_s)

s_{act} (in.)	Size	¾	½
	s_{cr}	8	10¾
	s_{min}	4	5¼
	f_{smin}	0.50	0.50
4		0.50	
4½		0.56	
5		0.63	
5¼		0.66	0.50
6		0.75	0.57
6½		0.81	0.62
7		0.88	0.66
7½		0.94	0.71
8		1.00	0.76
8½			0.80
9			0.85
9½			0.90
10			0.94
10¾			1.00



Edge Distance Shear (f_c)

Edge Dist. c_{act} (in.)	Size	¾	½
	c_{cr}	7	9¾
	c_{min}	3½	4¾
	f_{cmin}	0.45	0.45
3½		0.45	
4		0.53	
4½		0.61	
4¾		0.65	0.45
5		0.69	0.48
5½		0.76	0.54
6		0.84	0.60
6½		0.92	0.66
7		1.00	0.72
7½			0.78
8			0.84
8½			0.90
9			0.96
9¾			1.00



1. s_{act} = actual spacing distance at which anchors are installed (inches).
2. s_{cr} = critical spacing distance for 100% load (inches).
3. s_{min} = minimum spacing distance for reduced load (inches).
4. f_s = adjustment factor for allowable load at actual spacing distance.
5. f_{scr} = adjustment factor for allowable load at critical spacing distance. f_{scr} is always = 1.00.
6. f_{smin} = adjustment factor for allowable load at minimum spacing distance.
7. $f_s = f_{smin} + [(1 - f_{smin})(s_{act} - s_{min}) / (s_{cr} - s_{min})]$.

1. c_{act} = actual edge distance at which anchor is installed (inches).
2. c_{cr} = critical edge distance for 100% load (inches).
3. c_{min} = minimum edge distance for reduced load (inches).
4. f_c = adjustment factor for allowable load at actual edge distance.
5. f_{scr} = adjustment factor for allowable load at critical edge distance. f_{scr} is always = 1.00.
6. f_{cmin} = adjustment factor for allowable load at minimum edge distance.
7. $f_c = f_{cmin} + [(1 - f_{cmin})(c_{act} - c_{min}) / (c_{cr} - c_{min})]$.

* See page 12 for an explanation of the load table icons.

Hollow Drop-In Internally Threaded Anchor

The Simpson Strong-Tie® Hollow Drop-In Anchor (HDIA) is an internally threaded, flush-mount expansion anchor for use in hollow materials such as CMU and hollow-core plank, as well as in solid base materials such as brick, normal-weight and lightweight concrete.

Features:

- Suitable for suspending conduit, cable trays, pipe supports, fire sprinklers and suspended lighting into concrete
- Expansion design allows HDIA to anchor into CMU, hollow-core plank, brick, normal-weight concrete and lightweight concrete
- Internally threaded anchor allows for easy bolt removal

Material: Die-cast Zamac 3 alloy shell with carbon-steel cone or 304 stainless-steel cone

Codes: Factory Mutual 3053987 (3/8"–1/2" diameter)
Underwriters Laboratories EX3605 (3/8"–1/2" diameter)



Hollow Drop-In Anchor

Size	Model No.	Drill Bit Diameter (in.)	Threads (per in.)	Overall Anchor Length (in.)	Quantity	
					Pkg. Quantity	Carton Quantity
1/4"	HDIA25	3/8"	20	3/4"	100	1600
1/4"	HDIA25SS	3/8"	20	3/4"	100	1600
5/16"	HDIA31	5/8"	18	1 1/4"	50	200
3/8"	HDIA37	5/8"	16	1 1/4"	50	200
3/8"	HDIA37SS	5/8"	16	1 1/4"	50	200
1/2"	HDIA50	3/4"	13	1 3/4"	50	250
5/8"	HDIA62	1"	11	2"	25	125



Setting Tool for Hollow Materials*

Size	Model No.	For Use With	Quantity	
			Pkg. Quantity	Carton Quantity
1/4"	HDIASHT25	HDIA25, HDIA25SS	—	25
5/16"	HDIASHT31	HDIA31	—	25
3/8"	HDIASHT37	HDIA37, HDIA37SS	—	25
1/2"	HDIASHT50	HDIA50	—	25
5/8"	HDIASHT62	HDIA62	—	10



Setting Tool for Solid Materials*

Size	Model No.	For Use With	Quantity	
			Pkg. Quantity	Carton Quantity
1/4"	HDIASST25	HDIA25, HDIA25SS	25	125
5/16" – 3/8"	HDIASST31 – 37	HDIA31, HDIA37, HDIA37SS	10	50
1/2"	HDIASST50	HDIA50	10	50
5/8"	HDIASST62	HDIA62	5	20



* Tools sold separately. Tools may be ordered by the piece

Hollow Drop-In Internally Threaded Anchor

Installation Instructions — Solid Base (using solid setting tool)

- Drill a hole in the base material using the appropriate diameter carbide drill bit as specified in the table. Drill the hole to the specified embedment depth.
- Blow the hole clean using compressed air. Overhead installations need not be blown clean.
- Insert the HDIA into hole. Tap with hammer until flush against surface.
- Using the designated setting tool, drive the anchor to the bottom of the drilled hole. After the anchor reaches the bottom of the drilled hole, perform an additional 3 hammer blows against the setting tool to drive the anchor body over the cone.
- Position fixture; insert fastener and tighten.

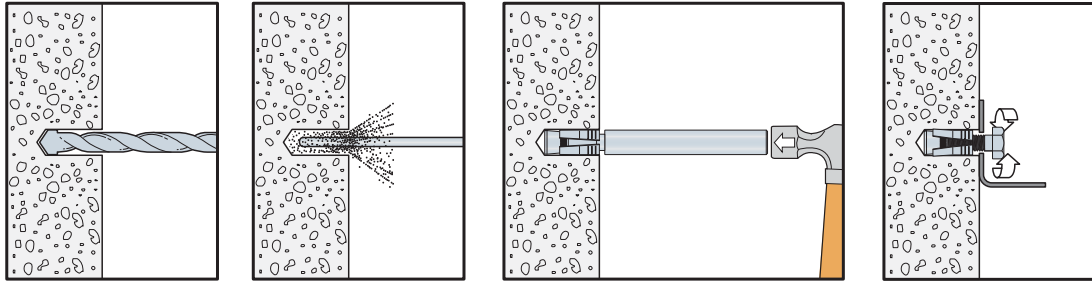

Installation Instructions — Hollow Base (using hollow setting tool)

- Drill a hole in the base material using the appropriate diameter carbide drill bit as specified in the table.
- Thread the HDIA onto the designated setting tool for hollow base materials.
- Insert the HDIA into the hole. Tap the setting tool until the face of the tool contacts the surface.
- Rotate the setting tool a minimum of 2 turns to set the anchor.
- Remove the setting tool.
- Position fixture; insert fastener and tighten.

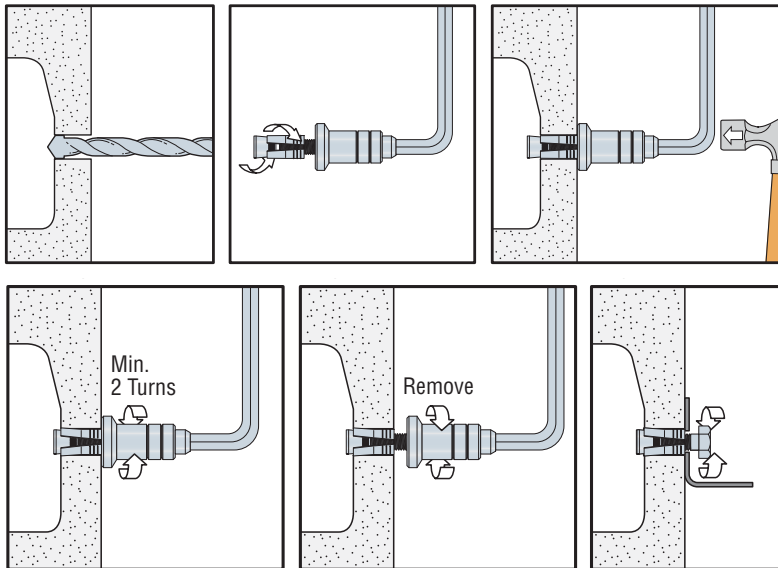

Hollow Drop-In Design Information — Concrete and Masonry

Allowable Tension Loads for Hollow Drop-In Anchor in Normal-Weight Concrete



Model No.	Size in. (mm)	Drill Bit Dia. in. (mm)	Embed Depth in. (mm)	Critical Edge Dist. in. (mm)	Critical Spacing in. (mm)	Tension Load			
						$f'_c \geq 2,500$ psi (17.2 MPa)		$f'_c \geq 4,000$ psi (27.6 MPa)	
						Ultimate lb. (kN)	Allowable lb. (kN)	Ultimate lb. (kN)	Allowable lb. (kN)
HDA25, HDIA25SS	1/4 (6.4)	3/8 (9.5)	7/8 (22)	2 5/8 (67)	3 1/2 (89)	1,180 (5.2)	295 (1.3)	1,220 (5.4)	305 (1.4)
HDA31	5/16 (7.9)	5/8 (15.9)	1 1/2 (38)	4 1/2 (114)	6 (152)	3,000 (13.3)	750 (3.3)	3,420 (15.2)	855 (3.8)
HDA37, HDIA37SS	3/8 (9.5)	5/8 (15.9)	1 1/2 (38)	4 1/2 (114)	6 (152)	3,000 (13.3)	750 (3.3)	3,420 (15.2)	855 (3.8)
HDA50	1/2 (12.7)	3/4 (19.1)	2 (51)	6 (152)	8 (203)	4,260 (18.9)	1,065 (4.7)	5,500 (24.5)	1,375 (6.1)
HDA62	5/8 (15.9)	1 (25.4)	2 1/4 (57)	6 3/4 (171)	9 (229)	6,100 (27.1)	1,525 (6.8)	6,300 (28.0)	1,575 (7.0)

1. The allowable loads listed are based on a safety factor of 4.0.
2. The minimum concrete thickness is 1 1/2 times the embedment depth.
3. Allowable loads may be linearly interpolated between concrete strengths listed.

Allowable Shear Loads for Hollow Drop-In Anchor in Normal-Weight Concrete



Model No.	Size in. (mm)	Drill Bit Dia. in. (mm)	Embed Depth in. (mm)	Critical Edge Dist. in. (mm)	Critical Spacing in. (mm)	Shear Load Based on Anchor Strength		Shear Load Based on Steel Strength	
						$f'_c \geq 2,500$ psi (17.2 MPa)		F1554 Grade 36	A193 Grade B7
						Ultimate lb. (kN)	Allowable lb. (kN)	Allowable lb. (kN)	Allowable lb. (kN)
HDA25, HDIA25SS	1/4 (6.4)	3/8 (9.5)	7/8 (22)	2 5/8 (67)	3 1/2 (89)	1,840 (8.2)	460 (2.0)	485 (2.2)	1,045 (4.6)
HDA31	5/16 (7.9)	5/8 (15.9)	1 1/2 (38)	4 1/2 (114)	6 (152)	2,660 (11.8)	665 (3.0)	755 (3.4)	1,630 (7.3)
HDA37, HDIA37SS	3/8 (9.5)	5/8 (15.9)	1 1/2 (38)	4 1/2 (114)	6 (152)	3,580 (15.9)	895 (4.0)	1,085 (4.8)	2,340 (10.4)
HDA50	1/2 (12.7)	3/4 (19.1)	2 (51)	6 (152)	8 (203)	8,220 (36.6)	2,055 (9.1)	1,930 (8.6)	4,160 (18.5)
HDA62	5/8 (15.9)	1 (25.4)	2 1/4 (57)	6 3/4 (171)	9 (229)	10,180 (45.3)	2,545 (11.3)	3,025 (13.5)	6,520 (29.0)

1. The allowable loads listed are based on a safety factor of 4.0.
2. The minimum concrete thickness is 1 1/2 times the embedment depth.
3. Allowable load must be the lesser of the load based on anchor strength or steel strength.

Allowable Tension and Shear Loads for Hollow Drop-In Anchor in 8" Lightweight, Medium-Weight and Normal-Weight Hollow CMU



Model No.	Size in. (mm)	Drill Bit Dia. in. (mm)	Embed Depth ⁴ in. (mm)	Minimum Edge Dist. in. (mm)	Minimum End Dist. in. (mm)	Minimum Spacing in. (mm)	Tension Load		Shear Load	
							Ultimate lb. (kN)	Allowable lb. (kN)	Ultimate lb. (kN)	Allowable lb. (kN)
HDA25, HDIA25SS	1/4 (6.4)	3/8 (9.5)	3/4 (19)	4 (102)	4 5/8 (117)	8 (203)	500 (2.2)	100 (0.4)	975 (4.3)	195 (0.9)
HDA31	5/16 (7.9)	5/8 (15.9)	1 1/4 (32)	4 (102)	4 5/8 (117)	8 (203)	500 (2.2)	100 (0.4)	1,450 (6.4)	290 (1.3)
HDA37, HDIA37SS	3/8 (9.5)	5/8 (15.9)	1 1/4 (32)	4 (102)	4 5/8 (117)	8 (203)	500 (2.2)	100 (0.4)	1,450 (6.4)	290 (1.3)
HDA50	1/2 (12.7)	3/4 (19.1)	1 3/4 (44)	4 (102)	4 5/8 (117)	8 (203)	1,525 (6.8)	305 (1.4)	2,300 (10.2)	460 (2.0)
HDA62	5/8 (15.9)	1 (25.4)	2 (51)	4 (102)	4 5/8 (117)	8 (203)	1,525 (6.8)	305 (1.4)	2,325 (10.3)	465 (2.1)

1. The allowable loads listed are based on a safety factor of 5.0.
2. Values for 8-inch wide lightweight, medium-weight, and normal-weight CMU.
3. The minimum specified compressive strength of masonry, f'_m , at 28 days with a minimum face shell thickness of 1 1/4" is 1,500 psi.
4. The installed end of the anchor may extend into the CMU cavity depending upon face shell thickness.

* See page 12 for an explanation of the load table icons.

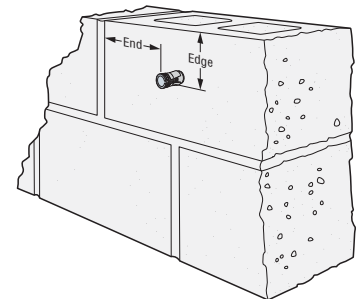

LSES Lag Screw Expansion Shield

The Lag Screw Expansion Shield is a die-cast zinc alloy expansion shield for anchoring lag screws in a variety of base materials, including concrete, concrete block, brick and mortar joints. Radial ribs provide additional holding power in softer material.

Material: Die-cast Zamac 3 alloy

Installation

Caution: Oversized holes may make it impossible to set the anchor and will reduce the anchor's load capacity.

1. Drill a hole in the base material using the appropriate diameter carbide drill bit as specified in the table. Drill the hole to the specified embedment depth plus 1/8" for flush mounting and blow it clean using compressed air. Alternatively, drill the hole deep enough to accommodate embedment depth and dust from drilling. Overhead installations need not be blown clean.
2. Insert anchor into hole. Tap with hammer until flush with surface of base material.
3. Position fixture, insert screw and tighten.



LSES

LSES Product Data and Allowable Tension Loads in Normal-Weight Concrete



Size (in.)	Model No.	Drill Bit Dia. (in.)	Embed. Depth (in.)	Allowable Tension Load (lb.) $f'_c \geq 3,000$ psi	Quantity	
					Box	Carton
1/4 Short	LSES25S	1/2	1	90	100	500
5/16 Short	LSES31S	1/2	1 1/4	100	100	500
3/8 Short	LSES37S	5/8	1 3/4	220	50	250
1/2 Short	LSES50S	3/4	2	250	25	125
1/4 Long	LSES25L	1/2	1 1/2	120	50	250
5/16 Long	LSES31L	1/2	1 3/4	150	50	250
3/8 Long	LSES37L	5/8	2 1/2	260	50	200
1/2 Long	LSES50L	3/4	3	310	25	100

1. The allowable loads listed are based on a safety factor of 4.0.
2. The minimum concrete thickness is 1 1/2 times the embedment depth.
3. Screw is not included.

Installation Sequence

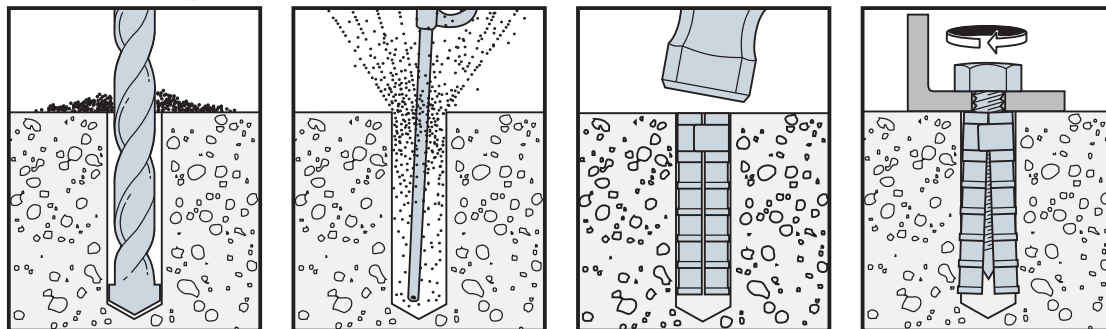

* See page 12 for an explanation of the load table icons.

ESA Expansion Screw Anchor

The ESA was the original internally threaded mechanical anchor design. The malleable lead shield allows for secure mounting.

Material: Cone: Die-cast Zamac 3 alloy; expander shield: 3–5% antimonial lead

Code: Meets Federal Specifications A-A-1922A, Type 1, except ESA50.

Installation

1. Drill a hole in the base material using the appropriate-diameter carbide drill bit as specified in the table. Drill the hole to the specified embedment depth plus 1/8" for flush mounting. Blow the hole clean using compressed air. Overhead installations need not be blown clean.
2. Insert anchor into hole.
3. Using a piloted setting punch, drive expander shield over cone.
4. Position fixture, insert fastener and tighten.



ESA



Piloted Setting Punch

ESA Product Data and Allowable Tension Loads in Normal-Weight Concrete



Internal Thread Size (dia. - threads per in.)	Model No.	Drill Bit Dia. (in.)	Embed. Depth (in.)	Allowable Tension Load (lb.)	Quantity	
				$f'_c \geq 3,000$ psi	Box	Carton
1/4 - 20	ESA25	1/2	7/8	190	100	500
3/8 - 16	ESA37	3/4	1 1/4	380	50	200
1/2 - 13	ESA50	7/8	1 1/2	400	50	200

Piloted Setting Punch Product Data

Model No.	For Use With	Box Qty.
PSP25	ESA25	10
PSP37	ESA37	10
PSP50	ESA50	10

Installation Sequence

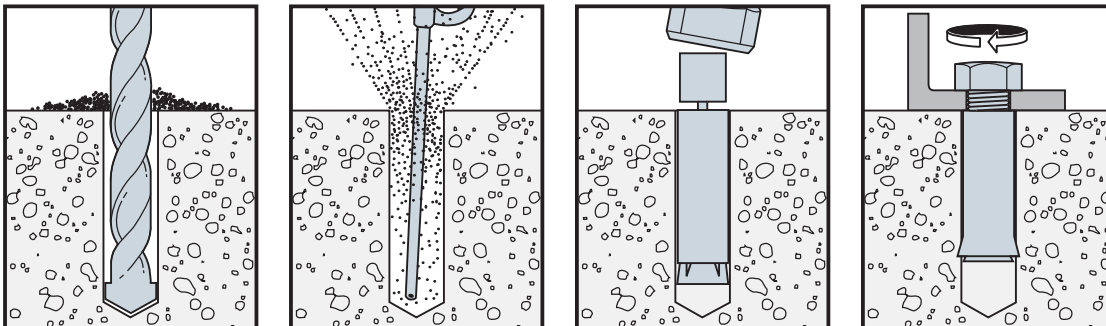

* See page 12 for an explanation of the load table icons.

Zinc Nail™ Pin Drive Anchors

Zinc Nail™ anchors are low-cost, easy-to-install anchors for applications under static loads.

Features



- Available with carbon and stainless-steel pins
- Pin and head configuration designed to make anchor tamper-resistant

Materials

- Body – Die-cast Zamac 3 alloy
- Pin – Carbon steel; Type 304 stainless steel

Code: Meets Federal Specification A-A-1925A, Type 1

Installation

-  **Caution:** Not for use in overhead applications.
-  **Caution:** Nailon anchors are not recommended for eccentric tension (prying) loads — capacity will be greatly reduced in such applications

1. Drill a hole in base material using a carbide drill bit the same diameter as the nominal diameter of the anchor to be installed. Drill the hole to specified embedment depth, plus ¼" for pin extension, and blow hole clean using compressed air. Alternatively, drill the hole deep enough to accommodate embedment depth and dust from drilling.
2. Position fixture and insert Nailon anchor.
3. Tap with hammer until flush with fixture, then drive pin until flush with top of head.



Zinc Nail™ Anchor
(Mushroom)

Mechanical Anchors

Zinc Nail™ Product Data

Size (in.)	Carbon Steel Pin Model No.	Stainless Steel Pin Model No.	Quantity		
			Box	Carton	Bulk
3/16 x 7/8	ZN18078	—	100	1,600	3,000
1/4 x 3/4	ZN25034	ZN25034SS	100	500	2,000
1/4 x 1	ZN25100	ZN25100SS	100	500	1,500
1/4 x 1 1/4	ZN25114	ZN25114SS	100	500	1,500
1/4 x 1 1/2	ZN25112	ZN25112SS	100	500	1,000
1/4 x 2	ZN25200	ZN25200SS	100	400	1,000
1/4 x 2 1/2	ZN25212	ZN25212SS	100	400	1,000
1/4 x 3	ZN25300	ZN25300SS	100	400	1,000

Allowable Tension and Shear Loads for Zinc Nail™ in Normal-Weight Concrete

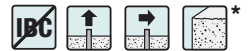

Size (in.)	Drill Bit Dia. (in.)	Embed. Depth (in.)	Ultimate Loads (lb.)		Allowable Loads (lb.) ¹	
			f'c ≥ 3,000 psi		f'c ≥ 3,000 psi	
			Tension	Shear	Tension	Shear
3/16	3/16	5/8	460	465	115	115
		3/4	590	635	150	160
1/4	1/4	3/4	780	765	195	190
		1 1/2	1,050	1,050	265	265

1. The allowable loads are based on a safety factor of 4.0.

Installation Sequence

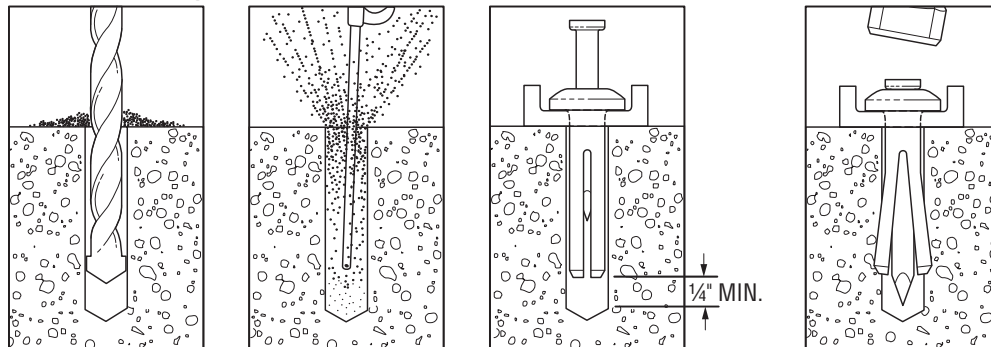

* See page 12 for an explanation of the load table icons.

Crimp Drive® Anchor

The Crimp anchor is an easy-to-install expansion anchor for use in concrete and grout-filled block. The pre-formed curvature along the shaft creates an expansion mechanism that secures the anchor in place and eliminates the need for a secondary tightening procedure. This speeds up anchor installation and reduces the overall cost.

Five crimp anchor head styles are available to handle different applications that include fastening wood or light-gauge steel, attaching concrete formwork, hanging overhead support for sprinkler pipes or suspended ceiling panels.

Material: Carbon steel

Coating: Zinc plated and mechanically galvanized

Codes: Factory Mutual 3031136 for the 3/8" Rod Coupler.

Head Styles: Mushroom, rod coupler, countersunk, tie-wire and duplex

Installation



Warning: Industry studies show that hardened fasteners can experience performance problems in wet or corrosive environments. Accordingly, with the exception of the duplex anchor, use these products in dry, interior and non-corrosive environments only.

1. Drill a hole using the specified diameter carbide bit into the base material to a depth of at least 1/2" deeper than the required embedment.
2. Blow the hole clean of dust and debris using compressed air. Overhead application need not be blown clean. Where a fixture is used, drive the anchor through the fixture into the hole until the head sits flush against the fixture.
3. Be sure the anchor is driven to the required embedment depth. The rod coupler and tie-wire models should be driven in until the head is seated against the surface of the base material.



Mushroom Head Rod Coupler Countersunk Head Tie-Wire Duplex

Crimp Drive® Anchor Product Data

Size (in.)	Model No.	Head Style/ Finish	Drill Bit Dia. (in.)	Min. Fixture Hole Size	Min. Embed. (in.)	Quantity				
						Pkg. Quantity	Carton Quantity			
3/16 x 1 1/4	CD18114M	Mushroom Head/ Zinc Plated	3/16	1/4	7/8	100	1600			
3/16 x 2	CD18200M				1 1/4	100	500			
3/16 x 2 1/2	CD18212M				1 1/4	100	500			
3/16 x 3	CD18300M				1 1/4	100	500			
3/16 x 3 1/2	CD18312M				1 1/4	100	500			
3/16 x 4	CD18400M				1 1/4	100	500			
1/4 x 1	CD25100M		1/4	5/16	7/8	100	1,600			
1/4 x 1 1/4	CD25114M				7/8	100	1,600			
1/4 x 1 1/2	CD25112M				1 1/4	100	1,600			
1/4 x 2	CD25200M				1 1/4	100	500			
1/4 x 2 1/2	CD25212M				1 1/4	100	500			
1/4 x 3	CD25300M				1 1/4	100	500			
1/4 x 3 1/2	CD25312M	3/8	7/16	1 1/4	100	500				
1/4 x 4	CD25400M			1 1/4	100	500				
3/8 x 2	CD37200M			1 3/4	25	125				
3/8 x 3	CD37300M			1 3/4	25	125				
1/4 x 3	CD25300MG			Mushroom Head/ Mechanically Galvanized	1/4	5/16	1 1/4	100	500	
1/4" Rod Coupler	CD25114RC			Rod Coupler/ Zinc Plated	3/16	N/A	1 1/4	100	500	
3/8" Rod Coupler	CD37112RC	Countersunk Head/ Zinc Plated	1/4	N/A	1 1/2	50	250			
3/16 x 2 1/2	CD18212C		3/16	1/4	1 1/4	100	500			
3/16 x 3	CD18300C				1 1/4	100	500			
3/16 x 4	CD18400C				1 1/4	100	500			
1/4 x 1 1/2	CD25112C				1 1/4	100	500			
1/4 x 2	CD25200C				1 1/4	100	500			
1/4 x 2 1/2	CD25212C				1 1/4	100	500			
1/4 x 3	CD25300C		1/4	5/16	1 1/4	100	500			
1/4 x 3 1/2	CD25312C				1 1/4	100	400			
1/4 x 4	CD25400C				1 1/4	100	400			
1/4 x 3	CD25300CMG				Countersunk Head/ Mechanically Galvanized ¹	1/4	5/16	1 1/4	100	500
1/4 x 4	CD25400CMG				1 1/4	100	400			
1/4" Tie Wire	CD25118T	Tie Wire/Zinc Plated			1/4	N/A	1 1/8	100	500	
1/4" Duplex	CD25234D	Duplex Head/ Zinc Plated	1/4	5/16	1 1/4	100	500			

1. Mechanical galvanizing meets ASTM B695, Class 55, Type 1. Intended for some pressure-treated wood sill plate applications. Not for use in other corrosive or outdoor environments. See page 316 for details.

Installation Sequence

Rod Coupler

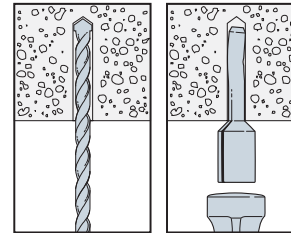

Tie-Wire

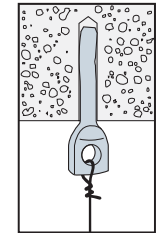

Mushroom Head

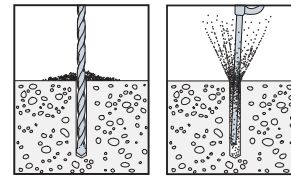

Duplex

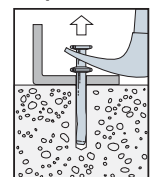

Duplex-head anchor may be removed with a claw hammer

Countersunk Head Installation Sequence

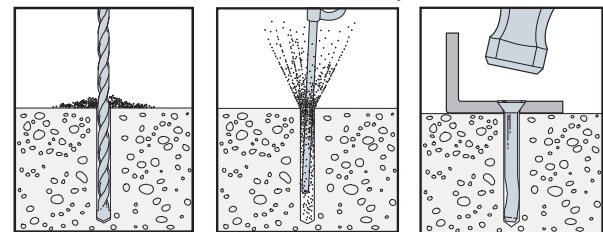

Crimp Drive® Design Information — Concrete

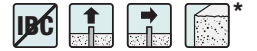

Allowable Tension and Shear Loads in Normal-Weight Concrete

Size (in.)	Drill Bit Dia. (in.)	Embed. Depth (in.)	Min. Spacing (in.)	Min. Edge Dist. (in.)	Tension Load		Shear Load	
					$f'_c \geq 2,000$ psi Concrete	$f'_c \geq 4,000$ psi Concrete	$f'_c \geq 2,000$ psi Concrete	$f'_c \geq 4,000$ psi Concrete
					Allowable Load (lb.)	Allowable Load (lb.)	Allowable Load (lb.)	Allowable Load (lb.)
Mushroom/Countersunk Head								
3/16	3/16	1 1/4	3	3	145	250	340	450
1/4	1/4	1 1/4	3	3	175	275	395	610
3/8	3/8	1 3/4	4	4	365	780	755	1,305
Duplex Head								
1/4	1/4	1 1/4	3	3	175	275	395	610
Tie Wire								
1/4	1/4	1 1/8	3	3	155	215	265	325
Rod Coupler⁴								
1/4	3/16	1 1/4	3	3	145	250	—	—
3/8	1/4	1 1/2	4	4	265	600	—	—

- The allowable loads listed are based on a safety factor of 4.0.
- The minimum concrete thickness is 1 1/2 times the embedment depth.
- Allowable loads may be linearly interpolated between concrete strengths listed.
- For rod coupler, mechanical and plumbing design codes may prescribe lower allowable loads; verify with local codes.

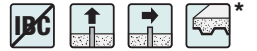

Allowable Tension and Shear Loads in Sand-Lightweight Concrete over Metal Deck

Size (in.)	Drill Bit Dia. (in.)	Embed. Depth (in.)	Min. Spacing (in.)	Min. Edge Dist. (in.)	Tension Load (Install in Concrete)	Tension Load (Install through Metal Deck)	Shear Load (Install in Concrete)	Shear Load (Install through Metal Deck)
					$f'_c \geq 3,000$ psi Concrete	$f'_c \geq 3,000$ psi Concrete	$f'_c \geq 3,000$ psi Concrete	$f'_c \geq 3,000$ psi Concrete
					Allowable Load (lb.)	Allowable Load (lb.)	Allowable Load (lb.)	Allowable Load (lb.)
Mushroom/Countersunk Head								
3/16	3/16	1 1/4	4	4	115	85	345	600
1/4	1/4	1 1/4	4	4	145	130	375	890
3/8	3/8	1 3/4	5 1/2	5 1/2	315	330	1,030	1,085
Duplex Head								
1/4	1/4	1 1/4	4	4	145	130	375	890
Tie Wire								
1/4	1/4	1 1/8	3	3	130	90	275	210
Rod Coupler⁴								
1/4	3/16	1 1/4	4	4	115	85	—	—
3/8	1/4	1 1/2	5	5	300	280	—	—

- The allowable loads listed are based on a safety factor of 4.0.
- The minimum concrete thickness is 1 1/2 times the embedment depth.
- Anchors may be installed off-center in the flute, up to 1" from the center of flute.
- Anchor may be installed in either upper or lower flute.
- Deck profile shall be 3" deep, 20-gauge minimum.
- For rod coupler, mechanical and plumbing design codes may prescribe lower allowable loads; verify with local codes.

Length Identification Head Marks on Mushroom, Countersunk and Duplex-Head Crimp Drive Anchors (corresponds to length of anchor – inches)

Mark	0	A	B	C	D	E	F
From	1	1 1/2	2	2 1/2	3	3 1/2	4
Up To But Not Including	1 1/2	2	2 1/2	3	3 1/2	4	4 1/2

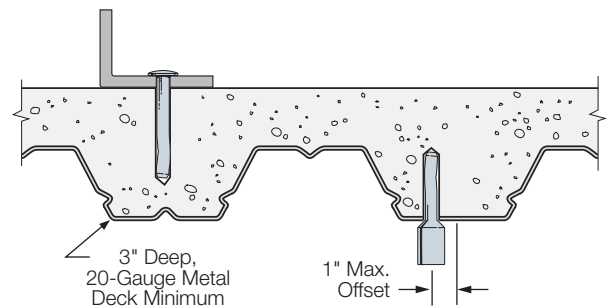

**Sand-Lightweight Concrete
On Metal Deck**

* See page 12 for an explanation of the load table icons.

CSD/DSD Split-Drive Anchors

The Split-Drive anchor is a one-piece expansion anchor that can be installed in concrete, grout-filled block and stone. As the anchor is driven in, the split-type expansion mechanism on the working end compresses and exerts force against the walls of the hole.



Features

- Available in countersunk (CSD) and duplex-head (DSD) styles
- DSD anchor can be removed with a claw hammer for temporary applications

Material: Carbon steel

Coating: Zinc plated; mechanically galvanized

Installation

-  **Warning (CSD only):** Industry studies show that hardened fasteners can experience performance problems in wet or corrosive environments. Accordingly, use these products in dry, interior and non-corrosive environments only.
-  **Caution:** Oversized holes in the base material will greatly reduce the anchor's load capacity. For CSD, embedment depths greater than 1 1/2" may cause bending during installation.

1. Drill a hole in base material using a 1/4"-diameter carbide-tipped drill. Drill hole to specified embedment depth and blow clean using compressed air. (Overhead installation need not be blown clean.) Alternatively, drill hole deep enough to accommodate embedment depth and dust from drilling. Position fixture and insert split-drive anchor through fixture hole.
2. For CSD, 3/8" diameter fixture hole is recommended for hard fixtures such as steel. For DSD, 5/16"-diameter fixture hole is recommended.
3. Drive anchor until head is flush against fixture.



DSD
(Duplex)

CSD
(Countersunk)

CSD/DSD Product Data

Size (in.)	Model No.	Head Style/Finish	Drill Bit Dia. (in.)	Quantity	
				Box	Carton
1/4 x 1 1/2	CSD25112	Countersunk Head – Zinc Plated	1/4	100	500
1/4 x 2	CSD25200			100	500
1/4 x 2 1/2	CSD25212			100	500
1/4 x 3	CSD25300			100	400
1/4 x 3 1/2	CSD25312			100	400
1/4 x 4	CSD25400	Countersunk Head – Mechanically Galvanized ¹	1/4	100	400
1/4 x 3	CSD25300MG			100	400
1/4 x 4	CSD25400MG			100	400
1/4 x 3	DSD25300	Duplex Head – Zinc Plated	1/4	100	400

1. Mechanical galvanizing meets ASTM B695, Class 55, Type 1. Intended for some preservative-treated wood sill plate applications. Not for use in other corrosive or outdoor environments. See page 316 for details.

CSD Allowable Tension and Shear Loads in Normal-Weight Concrete



Size (in.)	Drill Bit Dia. (in.)	Embed. Depth (in.)	Min. Spacing (in.)	Min. Edge Dist. (in.)	Tension Load (lb.)		Shear Load (lb.)	
					$f'_c \geq 2,000$ psi		$f'_c \geq 2,000$ psi	
					Ultimate Load	Allowable Load	Ultimate Load	Allowable Load
1/4	1/4	1 1/4	2 1/2	3	655	165	970	240

DSD Allowable Tension and Shear Loads in Normal-Weight Concrete



Size (in.)	Drill Bit Dia. (in.)	Embed. Depth (in.)	Min. Spacing (in.)	Min. Edge Dist. (in.)	Concrete Compressive Strength (psi)	Tension Load (lb.)		Shear Load (lb.)	
						Ultimate Load	Allowable Load	Ultimate Load	Allowable Load
						1/4	1/4	1 1/4	2 1/2
1/4	1/4	1 1/4	2 1/2	3	4,000	1,060	265	2,740	685

Installation Sequence

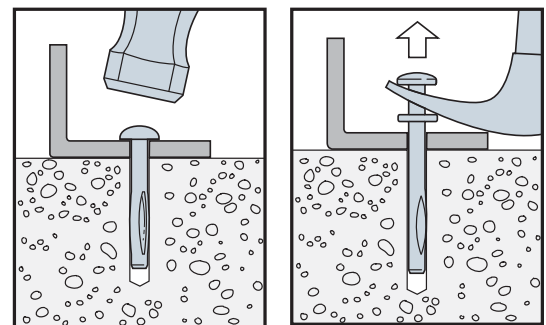
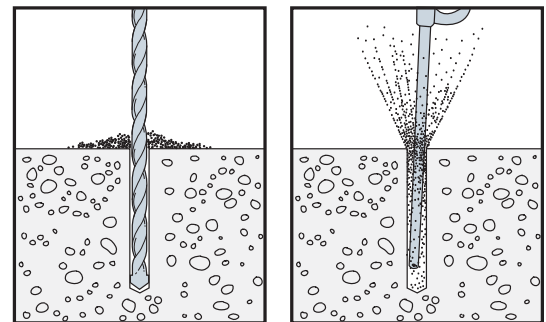

DSD anchor may be removed with a claw hammer

* See page 12 for an explanation of the load table icons.

Sure Wall Drywall Anchor

Sure Wall anchors are self-drilling drywall anchors and provide excellent holding value and greater capacity than screws alone. This anchor cuts threads into drywall, greatly increasing the bearing surface and strength of the fastening.

Features

- Self-drilling — may be installed in gypsum board drywall with only a screwdriver
- Easy to remove and reinstall

Material: Die-cast zinc or reinforced nylon

Sure Wall Product Data — Packaged with Screws

Screw Size	Model No.	Style	Quantity		Applications
			Box	Carton	
#6 x 7/8	SWN06S-R100	Nylon	100	500	3/8", 1/2" drywall, ceiling tile
#8 x 1 1/4	SWN08LS-R100	Nylon	100	500	3/8", 1/2" drywall, ceiling tile
#6 x 7/8	SWZ06S-R100	Zinc	100	500	3/8", 1/2" drywall, ceiling tile, plaster, pegboard
#8 x 1 1/4	SWZ08LS-R100	Zinc	100	500	3/8", 1/2", 5/8" drywall, plaster



Sure Wall
Nylon

Sure Wall
Zinc

Sure Wall Product Data — Packaged Without Screws

Screw Size	Model No.	Style	Quantity		Applications
			Box	Carton	
#6 x 7/8	SWN06-R100	Nylon	100	500	3/8", 1/2" drywall, ceiling tile
#8 x 1 1/4	SWN08L-R100	Nylon	100	500	3/8", 1/2" drywall, ceiling tile
#6 x 1	SWZ06-R100	Zinc	100	500	3/8", 1/2" drywall, ceiling tile, plaster, pegboard
#8 x 1 1/4	SWZ08L-R100	Zinc	100	500	3/8", 1/2", 5/8" drywall, plaster

Installation Sequence

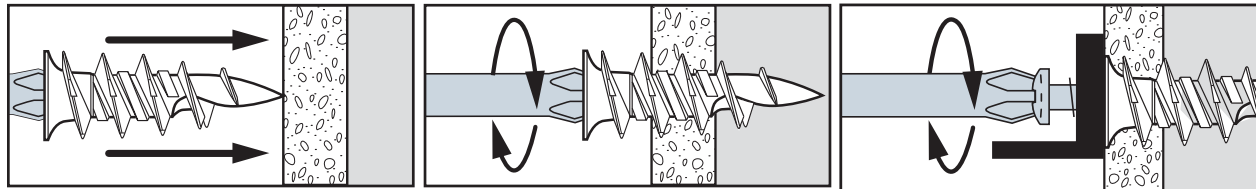

Direct Fastening Solutions



On the jobsite, time is money. That's why Simpson Strong-Tie offers a full range of gas- and powder-actuated tools and fasteners designed to maximize jobsite productivity and operator comfort in most applications.

Single-shot and fully automatic tool options efficiently drive our line of fasteners into concrete and steel. We also offer free online Powder-Actuated Tool certification at www.strongtie.com/pat.



GCN-MEPMAG Gas-Actuated Concrete Nailer

The GCN-MEPMAG and GCN-MEP gas-actuated concrete nailers are portable fastener tools for attaching light-duty fixtures to concrete, steel, concrete block (CMU), lightweight concrete over metal deck, and cold-formed steel. As a magazine tool, GCN-MEPMAG is ideal for attaching drywall track, furring strips, hat track and angle track using GDP and GDPS collated pins.

GCN-MEPMAG offers you the flexibility of having two tools in one convenient package — a magazine tool and a single-shot tool, since the magazine is easily removed without additional assembly tools. As a single-shot tool, the GCN-MEP is great for attaching mechanical, electrical and plumbing fixtures with pre-assembled pins/accessories such as washer pins, ceiling clips, tophats and threaded studs. The pre-assembled pins for the single-shot tool use 0.300"-headed fasteners with 0.125"-diameter shanks for stronger fastening performance.

Both the single-shot and magazine tool offer portability without the need for cords or hoses, and are actuated with GFC34 gas fuel cells.

Features

- Power to drive 0.125"-diameter pins
- Flexibility to drive ½" to 1½" pins
- Flexibility to drive 0.250" and 0.300" dia. headed pins
- Pin-depth adjustment dial
- Battery charge indicator light
- Comfortable "sure-grip" rubber handle and ladder hook
- Easy start-up procedure: Insert fuel cell, insert battery, load pins, and begin use
- FREE tool first-aid repair program (see back cover of operators manual)

Specifications

- Tool dimensions:
 - Length 12.5" (317.5 mm), 17" (432.8 mm)
 - Tool weight: 6.6 lb. (3 kg), 8.3 lb. (3.7 kg) with magazine
 - Height 15.3" (389 mm)
- Compatible fasteners:
 - Length: ½" (12.7 mm) to 1½" (38 mm)
 - Head diameter: 0.250" and 0.300"
 - Shank diameter: 0.106" to 0.125"
- Average number of shots per battery charge: 3,300
- Average number of shots per fuel cell: 1,200
- Average cyclic firing rate: 2 shots per second
- Average battery charge time (6V NiMH): 2 hours
- Operation temperature range: 20°–120°F (–6°–49°C)
- Magazine capacity: 42
- Maximum fastenings before reloading: 40

The magazine is designed to retain two pins during use to prevent the tool from discharging without a fastener (which can damage the tool and possibly cause injury). The tool will resume normal operation when additional pins are loaded.

Minimum Cleaning Required

The GCN-MEP has a very efficient ignition system that provides complete fuel combustion. This results in a cleaner operating tool, which, in turn, results in more tool energy and higher productivity. To maintain maximum level of productivity, periodic cleaning is recommended.

- Only requires cleaning every 20,000 shots
- Easy access to the air filter and piston chamber

The GCN-MEP MAG gas-actuated concrete nailer is ideal for fastening:

- Drywall track
- Lath wire for stucco
- Water-proofing membrane
- Furring strips



GCN-MEPMAG



MEP-MAG1KT
sold separately



GCN-MEPKT or GCN-MEPMAGKT
(with magazine)



Gas-Actuated Concrete Nailing

GDP Pins

GDP concrete pins are designed to work with the GCN-MEPMAG gas-actuated concrete nailer as well as with most major-brand gas-actuated concrete-nailer tools. The patented 10-fastener strip is designed with break-away plastic. The pins are designed for use in A36 and A572 steel, concrete, CMU block and sand-lightweight concrete over metal deck.

Codes: ICC-ES ESR-2811; Florida FL-15730; City of L.A. RR25837



GDP
(U.S. Patent 605,016)

0.106"-Diameter Shank Drive Pins

Model No.	Length (in.)	Qty. Pins / Pack +1 Fuel Cell	Packs/ Carton	Compatible with These Tools
GDP-50KT	½	1,000	5	Simpson Strong-Tie GCN-MEPMAG, Others: TF1100, C3, TF1200
GDP-62KT	⅝	1,000	5	
GDP-75KT	¾	1,000	5	
GDP-100KT	1	1,000	5	
GDP-125KT	1¼	1,000	5	
GDP-150KT	1½	1,000	5	

GDPS Pins

The GDPS pins are also designed to work in the GCN-MEPMAG gas-actuated nailer tool for installation into steel and concrete. The step-shank pin, with a smaller-diameter tip, facilitates easier penetration, while the larger-diameter upper shank provides more shear resistance and successful installation.



GDPS

0.118"/0.102"-Diameter Stepped-Shank Drive Pins

Model No.	Length (in.)	Qty. Pins / Pack + 1 fuel cell	Packs/ Carton	Compatible Tools	
				Simpson Strong-Tie	Others
GDPS-50KT	½	1,000	5	GCN-MEPMAG	TF1100, C3, TF1200
GDPS-62KT	⅝	1,000	5		
GDPS-75KT	¾	1,000	5		

Gas-Actuated Concrete Nailing

Spiral Knurl Gas Pins

GDPSK gas pins are designed for attaching plywood and OSB to cold-formed-steel studs. The spiral knurl provides a positive lock and resists back-out. Installed with the GCN-MEPMAG, the GDPSK-138 gas pin provides faster installation and setup times, which contributes to lower labor costs. The hardened pins quickly and cleanly pierce the cold-formed steel and leave the pin head flush with the wood fixture. The 1 3/8" length pin can be used for 1/2"-3/4" thick plywood, and 14-22 gauge steel.



GDPSK

Spiral Knurl Gas Pins

Model No.	Length (in.)	Qty. Pins / Pack + 1 fuel cell	Packs/ Carton	Compatible with These Tools
GDPSK-138KT	1 3/8	1,000	5	Simpson Strong-Tie: GCN-MEPMAG Others: TF1100, C3

GWL-100 Lathing Washer and GMR-2 Magnetic Ring

The GWL-100 lathing washer is used with the GCN-MEPMAG tool and attaches lath to the wall surface for overlaying scratch coats, brown coats and stucco. The washers are held onto the nose of the tool with the new GMR-2 magnetic ring and are attached to the substrate (including concrete and CMU) with GDP pins, which fasten through the washer. No extra tools are needed to install the magnetic ring to the nosepiece of the tool.



GWL-100



GMR-2

Lathing Washer and Magnetic Ring

Model No.	Description	Pack Qty.	Carton Qty.
GWL-100	Lathing Washer, 1" Diameter	1,000	5,000
GMR-2	Magnetic Ring for GCN150	10	900

Lathing Washer and Magnetic Rings are sold separately.

Fuel Cell

The GFC34 fuel cell is designed to operate with the GCN-MEPMAG and GCN-MEP, and with many major-brand gas-actuated concrete-nailer tools. The fuel cell provides 1,200 shots and can operate at temperatures between 20° and 120°F (-6°-49°C). The fuel cells are offered individually or in a two-per-pack clamshell. Additionally, one fuel cell is included with each pack of 1,000 pins.

Gas Fuel Cells for the GCN-MEP

Model No.	Description	Pack Qty.	Packs/ Carton	Compatible with These Tools
GFC34	34-gram fuel cells	12	—	Simpson Strong-Tie® GCN-MEP and GCN-MEPMAG Others: TrakFast® TF1100, Trak-It® C3
GFC34-RC2	(2) 34-gram fuel cells	2	6	



GFC Fuel Cell

Gas-Actuated Concrete Nailing

GCN-MEP Gas-Actuated Pins and Assemblies for Mechanical, Electrical and Plumbing (MEP) Applications

Pre-assembled MEP fasteners are available for use with the GCN-MEP concrete nailer designed for high-volume applications, such as affixing conduit clips, rod hangers, cable ties and ceiling clips.

With their 0.300" heads, these versatile pins and assemblies can also be used with common powder-actuated tools when fastening into harder substrates (structural steel or extra-hard concrete) when required.

Codes: ICC-ES ESR-2811; Florida FL-15730



Mechanical, Electrical and Plumbing Pins

All single-shot pins are 0.125" diameter x 1" except where specified.

Model No.	Description	Pack Qty.	Compatible Gas-Actuated Nailer
GRH25-R100	1/4" Rod hanger with pin	100	GCN-MEP, T3
GRH37-R100	3/8" Rod hanger with pin	100	GCN-MEP, T3
GCC50-R100	1/2" Conduit clip with pin	100	GCN-MEP, T3
GCC75-R100	3/4" Conduit clip with pin	100	GCN-MEP, T3
GCC100-R100	1" Conduit clip with pin	100	GCN-MEP, T3
GCC125-R50	1" Conduit clip (13 gauge steel) with pin	50	GCN-MEP, T3
GCL50-R50	1/2" Conduit clamp with pin	50	GCN-MEP, T3
GCL75-R25	3/4" Conduit clamp with pin	25	GCN-MEP, T3
GAC-R100	Angle clip with pin	100	GCN-MEP, T3
GCT-R50	Tie-strap holder with pin	50	GCN-MEP, T3
GW50-R200	1/2" Dome washer with 0.110" or 0.128" x 1/2" step-shank pin	200	GCN-MEP, T3
GW75-R200	1/2" Dome washer with 0.125 x 3/4" pin	200	GCN-MEP, T3
GW100-R100	1/2" Dome washer with pin	100	GCN-MEP, T3
GTS4-5075-R200	1/4" Threaded stud, 1/2" length 1/4-20 thread, 3/4" length shank (0.127" dia.)	200	GCN-MEP, T3
GTH-R200	Tophat pin	200	GCN-MEP, T3

Extension Pole Tools



Advantages

- Modular lengths – 2 ft., 6 ft., 8 ft.
- Lightweight
- Eliminates need for scaffolding
- Rugged and durable design

Extension Poles for PT-27

Model	Description	Quantity
PEPT6	Complete 6 ft. pole	1
PEPT8	Complete 8 ft. pole	1

Extension poles for PTP-27L, PTP-27S, PTP-27SMAGR, PTP-27LMAGR, GCN-MEPMAG and GCN-MEP

Model	Description	Quantity
PEPT6LR	Complete 6 ft. pole	1
PEPT8LR	Complete 8 ft. pole	1

PAT Tool / Fastener Matrix

This matrix matches Simpson Strong-Tie powder-actuated tools with the powder loads and fasteners typically used with each tool.

Fasteners	Page No.	Premium Tools				Heavy-Duty Tool	General-Purpose Tools			
		PTP-27L (page 256)	PTP-27LMAGR (page 256)	PTP-27S (page 258)	PTP-27SMAGR (page 258)		PT-27HDA (page 260)	PT-27 (page 261)	PT-22A (page 262)	PT-22HA (page 263)
Loads										
P22AC (levels 2, 3, 4)	265							ALL	ALL	ALL
P22LRSC (levels 4, 5, 6, 7)	265									
P25SL (levels 3, 4, 5)	265									
P27LVL (levels 4, 5, 6)	265					ALL				
P27SL (levels 2, 3, 4, 5)	265	ALL	ALL	ALL	ALL		ALL			
P27SL6	265	✓	✓	✓	✓					
0.300"-Headed Fasteners with 0.157" Shank Diameter										
PDPA-XXX	266	✓		✓		✓	✓	✓	Max 2½"	✓
PDPAW-XXX	266	✓		✓			✓	✓	✓	✓
PDPAWL-XXX	266	✓		✓			✓	✓	✓	✓
PDPAS-XXX	267	✓		✓						
PDPAT-XXX	267	✓		✓		✓	✓	✓	✓	✓
PCLDPA-XXX	267	✓		✓			✓	✓	✓	✓
PECLDPA-XXX	267	✓		✓			✓	✓	✓	✓
PTRHA3-XXX	267	✓		✓			✓	✓	✓	✓
0.300"-Headed Fasteners with 0.145" Shank Diameter										
PDPWL-XXSS	268	✓		Max 2"			✓	✓	✓	✓
PINW-XXX	268	✓		Max 2"			✓	✓	✓	✓
PINWP-XXX	268			Max 1½"			Max 2½"	✓	✓	Max 2½"
PHBC-XXX	269	Max 2½"		Max 1½"			Max 2½"	✓	✓	Max 2½"
PCC-XXX	269	✓		✓			✓	✓	✓	✓
PBXDP-100	269	✓		✓			✓	✓	✓	✓
8 mm-Headed Fasteners										
PHN-XXX	270	Max 2½"		Max 1½"		✓	Max 2½"	✓	✓	Max 2½"
PHNW-XXX	271			Max 2"			✓	✓	✓	✓
PHNT-XXX	271						✓	✓	✓	✓
PKP-250	271						✓	✓		✓
¾"-Headed Fasteners / Threaded Studs										
PSLV3-XXX	270					✓				
¼"-Headed Fasteners / Threaded Studs										
PSLV4-XXX	269	✓		Max 1½"		✓	✓	✓	✓	✓

PAT Tool Matrix Powder-Actuated Fastening Systems

This matrix matches Simpson Strong-Tie® powder-actuated tools with the trades that would typically use each tool. The selection is based upon the features of the tool matching the needs of the trade.

Premium Tools				
	PTP-27L	PTP-27LMAGR	PTP-27S	PTP-27SMAGR
				
Features	<ul style="list-style-type: none"> • Automatic • Adjustable Power • Low Recoil/Noise • 2 1/2" Pin Capacity (4" Pin with Washer) 	<ul style="list-style-type: none"> • Fully Automatic • 10-Fastener Magazine • Adjustable Power • Low Recoil/Noise • 2 7/8" Pin Capacity 	<ul style="list-style-type: none"> • Automatic • Adjustable Power • Low Recoil/Noise • Drywall Track Tool • 1 5/8" Pin Capacity 	<ul style="list-style-type: none"> • Fully Automatic • Rotating Fastener Magazine • 10-Fastener Magazine • Adjustable Power • Low Recoil/Noise • 1 1/4" Pin Capacity
Cold-Formed Steel	Best	Better	Best	Better
Drywall	Good	Good	Best	Best
Electrical	Better		Better	
General	Best	Best		
Framer	Best	Best		
Plumbing/ Fire Sprinkler				
Acoustical/ Overhead	Good		Best	
Remodeling	Better	Better		
Carpentry	Better	Better		
Flooring	Better	Better	Good	Good
Glazing			Better	
HVAC	Better		Best	
Rental	Better			

PAT Tool Matrix Powder-Actuated Fastening Systems

This matrix matches Simpson Strong-Tie® powder-actuated tools with the trades that would typically use each tool. The selection is based upon the features of the tool matching the needs of the trade.

	Heavy-Duty Tool	General-Purpose Tools			
	PT-27HDA	PT-27	PT-22A	PT-22HA	PT-22P
					
Features	<ul style="list-style-type: none"> • Heavy-Duty • Single .27 Caliber Shot – Long • Reliable Design • 3/8" Threaded Stud Sprinkler Tool with Stop Spall 	<ul style="list-style-type: none"> • Semi-Automatic • Versatile • Reliable Professional Grade Tool • 2 1/2" Pin Capacity (4" Pin with Washer) 	<ul style="list-style-type: none"> • Single-Shot • Economical Professional-Grade Tool • 3" Pin Capacity (4" Pin with Washer) 	<ul style="list-style-type: none"> • Single-Shot • Hammer-Activated • Medium-Duty • 3" Pin Capacity 	<ul style="list-style-type: none"> • Single-Shot • Versatile, Professional-Grade Tool • 1 1/2" Pin Capacity • 2" Pin with Washer
Drywall		Good			Best
Electrical		Good	Good	Good	Better
General		Better	Good		
Framer		Good	Good		
Plumbing/ Fire Sprinkler	Best				Good
Acoustical/ Overhead		Better	Good		Better
Remodeling		Better	Best	Best	Good
Carpentry		Best	Better	Better	
Flooring	Best				
Glazing		Good	Good		Better
Hvac		Better			
Rental					

Direct Fastening

PTP-27L and PTP-27LMAGR Premium Tools

The PTP-27L and the PTP-27LMAGR are powder-actuated fastening tools designed to provide versatility and ease of use on the jobsite. Both tools deliver productive fastening with automatic piston reset, which enables the user to simply load and shoot. The PTP-27L is a single-shot tool with a longer barrel that can be easily affixed with a fastener magazine. The PTP-27LMAGR is a fully automatic tool with a fastener magazine that can rotate for easier access, or it can be quickly changed to a single-shot tool.

Features

- Adjustable power for fastening versatility: 1–1½ power-level range from a single strip
- Easy disassembly for cleaning and maintenance
- No manual resetting of piston required
- Operator comfort: cushioned grip, reduced recoil and sound-dampening muffler for quiet operation

Key Fastening Applications

- Sill plate installation
- Washered-pin installation (PTP-27L only)
- Insulation fastening (PTP-27L only)
- Forming work
- Cold-formed steel

Specifications

- Fastener Length:
PTP-27L: ½" – 2½" (3" or 4" washered)
PTP-27LMAGR: ⅝" – 2⅞"
- Fastener Type: 0.300" (or 8 mm) diameter headed
- Firing Action:
PTP-27L: Automatic
PTP-27LMAGR: Fully automatic
- **Load Caliber:** 0.27 strip loads, brown through purple (levels 2–6)
- **Length:** 17¾" (PTP-27L), 19½" (PTP-27LMAGR)
- **Weight:** PTP-27L – 6.5 lb., PTP-27LMAGR – 8.8 lb.

Available Kit Combinations

PTP-27L: Single-shot configuration with accessories

PTP-LMAGR: Parts to convert PTP-27L into magazine configuration

PTP-27LMAGR: Magazine configuration with accessories

PTP-LCONKT: Parts to convert PTP-27LMAGR into a single-shot configuration

PTP-27LMAGRKT: Combination kit; includes tool and components for both single-shot and magazine configurations



Adjustable power increases versatility



The full line of Simpson Strong-Tie® powder loads and fasteners begins on page 265

Tool is sold in a rugged tool box complete with

- Operator's manual
- Spall suppressor
- Tools for disassembly
- Safety glasses / ear plugs
- Tool lubricant
- Cleaning brushes
- Operator's exam and caution sign
- Tool box also sold separately
- Gloves

PTP-27L and PTP-27LMAGR Premium Tools



Quick-disconnect baseplate makes it easy to convert the PTP-27LMAGR from a magazine to a single-shot tool.

Complementary Products

Extension pole tool for the PTP-27L and PTP-27LMAGR available in 6' and 8' lengths



Extension Pole Tool (for the PTP-27L) — See page 252 for details.

Replacement Parts – PTP-27L

Description	Model No.
Baseplate	PTP-274800
Nosepiece	PTP-273820
Piston	PTP-273320
Piston Disc	PTP-273306
Rubber Returner	PTP-274305

Replacement Parts – PTP-27LMAGR

Description	Model No.
Magazine (Complete)	PTP-LMAGR
Nosepiece	PTP-276820
Nosepiece Screw	PTP-275826
Piston	PTP-276320
Piston Disc	PTP-273306
Rubber Returner	PTP-274305

Complete tool schematics, tool repair, maintenance kits and parts list are available at www.strongtie.com.

PTP-27S and PTP-27SMAGR Premium Tools

The PTP-27S and the PTP-27SMAGR are powder-actuated fastening tools designed to provide versatility and ease of use on jobs that require shorter fasteners. Both tools deliver productive fastening with automatic piston reset, which enables the user to simply load and shoot. The PTP-27S is a single-shot tool with a shorter barrel that can be easily affixed with a fastener magazine. The PTP-27SMAGR is a fully automatic tool with rotational fastener magazine that can be quickly changed to a single-shot tool.

Features

- Adjustable power for fastening versatility: 1–1½ power-level range from a single strip
- Operator comfort from cushioned grip, reduced recoil and sound-dampening muffler for quiet operation
- No manual resetting of piston required
- Easy disassembly for cleaning and maintenance

Key Fastening Applications

PTP-27S:

- Conduit clips
- Ceiling clips
- Drywall track
- Metal Decking

PTP-27SMAGR:

- Drywall track
- Hat channel
- HVAC duct straps
- Cold-formed steel
- Furring strips

Specifications

- Fastener Length:
PTP-27S: ½"–1 ⅝"
PTP-27SMAGR: ½"–1 ¼"
- Fastener Type: 0.300" or 8 mm diameter
- Firing Action:
PTP-27S: Automatic
PTP-27SMAGR: Fully automatic
- **Load Caliber:** 0.27 strip loads, brown through purple (levels 2–6)
- **Length:** 16¾" (PTP-27S), 17½" (PTP-27SMAGR)
- **Weight:** PTP-27S – 6.25 lb., PTP-27SMAGR – 8.1 lb.



Adjustable power increases versatility



The full line of Simpson Strong-Tie® powder loads and fasteners begins on page 265.

Available Kit Combinations:

PTP-27S: Single-shot configuration with accessories

PTP-SMAGR: Parts to convert PTP-27S into magazine configuration

PTP-27SMAGR: Magazine configuration with accessories

PTP-SCONKT: Parts to convert PTP-27SMAGR into a single-shot configuration

PTP-27SMAGRKT: Combination kit; includes tool and components for both single-shot and magazine configurations

Tool is sold in a rugged tool box complete with

- Operator's manual
- Spall suppressor
- Tools for disassembly
- Safety glasses / ear plugs
- Tool lubricant
- Cleaning brushes
- Operator's exam and caution sign
- Tool box also sold separately
- Gloves

PTP-27S and PTP-27SMAGR Premium Tools



Rotating magazine allows for installation flexibility.



Quick-disconnect baseplate makes it easy to convert the PTP-27SMAGR from a magazine to a single-shot tool.



Collated pins make for fully automatic fastening and quick loading.

Complementary Products

Extension pole tool for the PTP-27S and PTP-27SMAGR available in 6' and 8' lengths



Extension Pole Tool (for the PTP-27S) — See page 252 for details.

Replacement Parts – PTP-27S

Description	Model No.
Baseplate	PTP-273800
Nosepiece	PTP-273820
Piston	PTP-273320
Piston Disc	PTP-273306
Rubber Returner	PTP-273305

Replacement Parts – PTP-27SMAGR

Description	Model No.
Magazine Body (Complete)	PTP-SMAGR
Nosepiece	PTP-275800
Nosepiece Screw	PTP-275826
Piston	PTP-273320
Piston Disc	PTP-273306
Rubber Returner	PTP-273305

Complete tool schematics, tool repair, maintenance kits and parts list are available at www.strongtie.com.

PT-27HDA Powder-Actuated Heavy-Duty Stud Driver

The PT-27HDA is a low-velocity, heavy-duty powder-actuated tool designed for installing fasteners into poured and precast concrete, grout-filled concrete masonry block and horizontal grouted joints, as well as structural steel. This tool offers easy-cycling, single-shot firing action for continuous use, high reliability and low maintenance. The PT-27HDA features a spall suppressor, which reduces concrete spalling and helps keep the tool perpendicular to the work surface.

Key features

- Heavy-duty stud driver for installing fasteners into steel or hard concrete
- Easy cycling – pulling on the barrel ejects the shell and resets the piston
- Low recoil for greater operator comfort
- Spall suppressor to reduce concrete spalling and keep tool perpendicular to work surface
- Consistent and reliable performance
- Easy disassembly for cleaning and maintenance

Specifications

- Fastener length: 5/8" through 3"
- Fastener types: 1/4" – 20-threaded studs, 3/8" – 16-threaded studs, 8 mm-headed fasteners and 0.300"-headed fasteners with 0.157" shank diameter
- Firing action: Single shot
- Load caliber: 0.27 long single loads, yellow through purple (levels 3–6)
- Length: 14 1/2"
- Weight: 8 lb., 13 oz.

Key Fastening Applications

- 3/8" sprinkler fastenings
- Heavy-duty fastening in concrete strengths up to 8,000 psi
- Structural steel

PT-27HDA is sold in a durable box complete with

- Operator's manual
- Spall suppressor
- 8 mm fastener guide and pistons for use with PDPA, PSLV4 and PHN pins
- 10 mm fastener guide and pistons for use with PSLV3 pins
- Safety glasses / ear plugs
- Tool lubricant
- Cleaning brushes
- Operator's exam and caution sign
- 2 extra stop rings



PT-27HDA



Kit contents for PT-27HDA



Easy cycling: simply pull to eject the shell

Replacement Parts – PT-27HDA

Description	Model No.
8 mm Piston	PTHDA-700320
8 mm Guide Assembly	PTHDA-700340
10 mm Piston	PTHDA-700310
10 mm Guide Assembly	PTHDA-700330
Stop Ring / Buffer	PTHDA-700302

PT-27 General Purpose Tool

The PT-27 is a semi-automatic and fast-cycling fastening tool that is engineered for continuous use, high reliability and low maintenance. This versatile tool fires a variety of fastener types and lengths.

Key Fastening Applications

- Acoustical ceilings
- Electrical applications
- Sill plates
- Drywall track
- Water proofing material and/or lathing

Specifications

- Fastener Length: ½" – 2½" (3" or 4" washered)
- Fastener Type: .300" or 8 mm-headed fasteners or ¼"-20 threaded studs
- Firing Action: Semi-automatic
- Load Caliber: 0.27 strip loads, brown through red (levels 2–5)
- Length: 13½"
- Weight: 5 lb., 4 oz.

Tool is sold in a rugged tool box complete with

- Operator's manual
- Spall suppressor
- Tools for disassembly
- Safety glasses / ear plugs
- Tool lubricant
- Cleaning brushes
- Operator's exam and caution sign



PT-27



The full line of Simpson Strong-Tie® powder loads and fasteners begins on page 265

Replacement Parts – PT-27

Description	Model No.
Annular Spring	PT-301014
Ball Bearing (6 mm)	PT-301013
Barrel	PT-301006
Baseplate	PT-301009
Piston – Concave (includes ring)	PT-301217
Piston – Flat (includes ring)	PT-301903
Piston Ring	PT-301208
Piston Stop	PT-301012
Shear Clip	PT-301011

For tool repair and maintenance kits and complete tool schematics and parts list, visit www.strongtie.com.

Complementary Products

Extension pole tool for the PT-27 available in 6' and 8' lengths

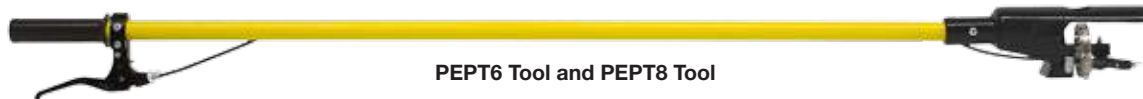

PEPT6 Tool and PEPT8 Tool

Extension Pole Tool (for the PT-27) – see page 252 for details.

PT-22A General-Purpose Tool

The PT-22A is a powder-actuated tool that uses 0.22 caliber “A” crimp loads, has single-shot firing action and is engineered for continuous use, high reliability and low maintenance.

Key Fastening Applications

- Furring strips
- Framing pins
- Electrical boxes
- Ceiling clips

Specifications

- Fastener Length: ½" – 3" (3" and 4" washered)
- Fastener Type: 0.300" or 8-mm headed fasteners or ¼"-20 threaded studs
- Firing Action: Single shot
- Load Caliber: 0.22 single “A” crimp loads, brown through yellow (levels 2–4). Note: Not for use with 0.22-caliber straight wall loads.
- Length: 13⅞"
- Weight: 4.4 lb.

Tool is sold in a rugged tool box complete with:

- Operator’s manual
- Spall guard
- Tools for disassembly*
- Safety glasses / ear plugs*
- Cleaning brushes*
- Operator’s exam and caution sign*

*These items not supplied with the PT-22A-RB retail package.



PT-22A



The PT-22A is sold individually in a tool box with accessories or in a retail package (see below).

The full line of Simpson Strong-Tie® powder loads and fasteners begins on page 265

PT-22A Retail Package Product Data

Description	Model No.	Qty. of Tools Per Retail Package	Qty. of Retail Packages Per Carton
.22 Caliber, Single-Shot Trigger-Activated Tool	PT-22A-RB	1	2

Replacement Parts

Description	Model No.
Nosepiece	PT22A-01
Piston Buffer	PT22A-02
Piston Reset Cap	PT22A-13
Piston Reset Pin	PT22A-11
Piston Reset Spring	PT22A-12
Piston with Ring	PT22A-03

1. Model PT-DC108 for tools with a serial number below 5000.
2. Model PT-DC107 for tools with a serial number below 5000.
3. Model PT-DC122 for tools with a serial number below 5000.
4. Complete tool schematics and parts list available at www.strongtie.com.



PT-22A-RB

PT-22HA General-Purpose Tool

The PT-22HA is a hammer-activated tool engineered for low maintenance and economy. The tool offers three levels of power: Brown through yellow loads (levels 2–4).

Key Fastening Applications

- Remodeling
- Maintenance
- Electricians
- Telecommunications



PT-22HA

Specifications

- Fastener Length: ½"–3" (4" washered)
- Fastener Type: 0.300" or 8 mm-headed fasteners or ¼"-20 threaded studs
- Firing Action: Single shot, hammer activated
- Load Caliber: 0.22 single "A" crimp loads, brown through yellow (levels 2–4). Note: Not for use with 0.22-caliber straight wall loads.
- Length: 14 ¼"
- Weight: 2 lb., 12 oz.

PT-22H Retail Package Product Data

Description	Model No.	Qty. of Tools Per Retail Package	Qty. of Retail Packages Per Carton
0.22 Caliber, Single-Shot Hammer-Activated Tool	PT-22HA-RB	1	4



The PT-22HA-RB comes packaged in a retail clamshell ready for merchandising.



Direct Fastening

PT-22P Powder-Actuated Tool

The PT-22P is a single-shot fastening tool engineered for continuous use, high reliability and low maintenance. The all-aluminum body of the PT-22P also provides rugged durability.

Key Fastening Applications

- Drywall track
- Furring strips
- Framing pins
- Electrical boxes
- Ceiling clips

Specifications

- Fastener Length: ½"–1½"
- Fastener Type: 0.300" or 8 mm-headed fasteners or ¼"-20 threaded studs
- Firing Action: Single shot
- Load Caliber: 0.22 single "A" crimp loads, brown through yellow (levels 2-4). Note: Not for use with 0.22-caliber straight wall loads.
- Length: 14"
- Weight: 4 lb. 7 oz.

Tool is sold in a rugged tool box complete with

- Operator's manual
- Spall guard
- Tools for disassembly
- Safety glasses / ear plugs
- Cleaning brushes
- Operator's exam and caution sign
- One additional piston



PT-22P



The PT-22P is sold individually in a tool box with accessories.

Replacement Parts

Description	Model No.
Nosepiece	PT-22P-01
Stop Pin Cover	PT-22P-17
Barrel Stop Pin	PT-22P-20
Barrel Stop Pin Spring	PT-22P-21
Piston with Ring	PT-22P-02

Powder Loads for Powder-Actuated Tools

0.22-Caliber "A" Crimp Loads – Single Shot

Description	Model	Pack Qty.	Carton Qty.	Compatible Tools	
				Simpson	Others
.22 Cal. – Brown (Level 2)	P22AC2	100	10,000	PT-22A PT-22GS PT-22HA PT-22P	721, U-2000, DX-37E, DX72E, 4170 and model 70, System 3 and most low-velocity, single-shot tools
	P22AC2A	100	10,000		
.22 Cal. – Green (Level 3)	P22AC3	100	10,000		
	P22AC3A	100	10,000		
.22 Cal. – Yellow (Level 4)	P22AC4	100	10,000		
	P22AC4A	100	10,000		



P22AC

0.22-Caliber Straight Wall Loads – Single Shot

Description	Model	Pack Qty.	Carton Qty.	Compatible Tools
.22 Cal. – Yellow (Level 4)	P22LRSC4	100	10,000	Ladd Tools, and some special application tools
.22 Cal. – Red (Level 5)	P22LRSC5	100	10,000	
.22 Cal. – Purple (Level 6)	P22LRSC6	100	10,000	
.22 Cal. – Gray (Level 7)	P7LRSC	100	10,000	



P22LRSC

Note: Not for use with Simpson Strong-Tie PT-22, PT-22GS, or PT-22H tools.

0.25-Caliber Plastic 10-Shot Strip Loads

Description	Model	Pack Qty.	Carton Qty.	Compatible Tools
.25 Cal. – Green (Level 3)	P25SL3	100	10,000	DX35, R355
.25 Cal. – Green BULK PACK	P25SL3M	1,000	5,000	
.25 Cal. – Yellow (Level 4)	P25SL4	100	10,000	
.25 Cal. – Yellow BULK PACK	P25SL4M	1,000	5,000	
.25 Cal. – Red (Level 5)	P25SL5	100	10,000	
.25 Cal. – Red BULK PACK	P25SL5M	1,000	5,000	



P25SL

0.27-Caliber Single-Shot Loads – Long

Description	Model	Pack Qty.	Carton Qty.	Compatible Tools
.27 Cal. – Yellow (Level 4)	P27LVL4	100	10,000	PT-27HDA, DX460, and Hilti DX600
.27 Cal. – Red (Level 5)	P27LVL5	100	10,000	
.27 Cal. – Purple (Level 6)	P27LVL6	100	10,000	



P27LVL

0.27-Caliber Plastic, 10-Shot Strip Loads

Description	Model	Pack Qty.	Carton Qty.	Compatible Tools	
				Simpson Strong-Tie	Others
.27 Cal. – Brown (Level 2)	P27SL2	100	10,000	PTP-27L, PTP-27MAGR, PTP-27S, PTP-27SMAGR, PT-27	DX-350, DX-351, DX-36, DX-A40 (except PT27SL2), DX-A41 (except PT27SL2 and PT27SL3), DX-460, DX-450, DX-451, DX-460, System 1H, P-36B, A-40B, A-41B, Cobra and most 0.27-caliber clone tools
	P27SL2A	100	10,000		
.27 Cal. – Green (Level 3)	P27SL3	100	10,000		
	P27SL3A	100	10,000		
.27 Cal. – Green BULK PACK	P27SL3M	1,000	5,000		
.27 Cal. – Yellow (Level 4)	P27SL4	100	10,000		
	P27SL4A	100	10,000		
.27 Cal. – Yellow BULK PACK	P27SL4M	1,000	5,000		
.27 Cal. – Red (Level 5)	P27SL5	100	10,000		
	P27SL5A	100	10,000		
.27 Cal. – Red BULK PACK	P27SL5M	1,000	5,000		
.27 Cal. – Purple (Level 6)	P27SL6	100	10,000		DX-450, DX-451, DX-A41

Note: An "A" in a part number denotes imported load. No "A" indicates a domestic load.



P27SL

Fasteners for Powder-Actuated Tools

PDPA Drive Pins

- Manufactured with tight tolerances for superior performance
- Code-listed per ICC-ES ESR-2138; City of L.A. RR25469; Florida FL-15730

0.300"-Headed Fasteners with 0.157" Shank Diameter

Length (in.)	Model No.	Description	Pack Qty.	Carton Qty.	Compatible Tools	
					Simpson Strong-Tie	Others
½	PDPA-50	0.157 x ½"	100	1,000	PTP-27L PTP-27S PT-27 PT-27HDA PT-22A PT-22GS PT-22P PT-22HA	721, D-60, U-2000 and most other low-velocity tools
½ knurled	PDPA-50K	0.157 x ½" knurl	100	1,000		
⅝ knurled	PDPA-62K	0.157 x ⅝" knurl	100	1,000		
¾	PDPA-75	0.157 x ¾"	100	1,000		
1	PDPA-100	0.157 x 1"	100	1,000		
1 ⅙	PDPA-106	0.157 x 1 ⅙"	100	1,000		
1 ¼	PDPA-125	0.157 x 1 ¼"	100	1,000		
1 ⅝	PDPA-131	0.157 x 1 ⅝"	100	1,000		
1 ½	PDPA-150	0.157 x 1 ½"	100	1,000		
1 ⅞	PDPA-187	0.157 x 1 ⅞"	100	1,000		
2	PDPA-200	0.157 x 2"	100	1,000		
2 ½	PDPA-250	0.157 x 2 ½"	100	1,000		
2 ⅞	PDPA-287	0.157 x 2 ⅞"	100	1,000		



PDPA

This model available in mechanically galvanized finish (PDPA-287MG).

0.300"-Headed Fasteners with 0.157" Shank Diameter and ¾" Metal Washers

Length (in.)	Model No.	Description	Pack Qty.	Carton Qty.	Compatible Tools	
					Simpson Strong-Tie	Others
½	PDPAW-50	0.157 x ½", w/ ¾" washer	100	1,000	PTP-27L PTP-27S PT-27 PT-22P PT-22A PT-22GS PT-22HA	721, D-60, U-2000, System 1, System 3 and most other low-velocity tools
½ knurled	PDPAW-50K	0.157 x ½" knurl, w/ ¾" washer	100	1,000		
⅝ knurled	PDPAW-62K	0.157 x ⅝" knurl, w/ ¾" washer	100	1,000		
¾	PDPAW-75	0.157 x ¾", w/ ¾" washer	100	1,000		
1	PDPAW-100	0.157 x 1", w/ ¾" washer	100	1,000		
1 ¼	PDPAW-125	0.157 x 1 ¼", w/ ¾" washer	100	1,000		
1 ½	PDPAW-150	0.157 x 1 ½", w/ ¾" washer	100	1,000		
1 ⅞	PDPAW-187	0.157 x 1 ⅞", w/ ¾" washer	100	1,000		
2	PDPAW-200	0.157 x 2", w/ ¾" washer	100	1,000		
2 ½	PDPAW-250	0.157 x 2 ½", w/ ¾" washer	100	1,000		
2 ⅞	PDPAW-287	0.157 x 2 ⅞", w/ ¾" washer	100	1,000		



PDPAW

0.300"-Headed Fasteners with 0.157" Shank Diameter and 1" Metal Washers

Length (in.)	Model No.	Description	Pack Qty.	Carton Qty.	Compatible Tools	
					Simpson Strong-Tie	Others
½	PDPAWL-50	0.157 x ½", w/ 1" washer	100	1,000	PTP-27L PTP-27S PT-27 PT-22P PT-22A PT-22GS PT-22HA	721, D-60, U-2000, System 1, System 3 and most other low-velocity tools
½ knurled	PDPAWL-50K	0.157 x ½" knurl, w/ 1" washer	100	1,000		
⅝ knurled	PDPAWL-62K	0.157 x ⅝" knurl, w/ 1" washer	100	1,000		
¾	PDPAWL-75	0.157 x ¾", w/ 1" washer	100	1,000		
1	PDPAWL-100	0.157 x 1", w/ 1" washer	100	1,000		
1 ¼	PDPAWL-125	0.157 x 1 ¼", w/ 1" washer	100	1,000		
1 ½	PDPAWL-150	0.157 x 1 ½", w/ 1" washer	100	1,000		
1 ⅞	PDPAWL-187	0.157 x 1 ⅞", w/ 1" washer	100	1,000		
2	PDPAWL-200	0.157 x 2", w/ 1" washer	100	1,000		
2 ½	PDPAWL-250	0.157 x 2 ½", w/ 1" washer	100	1,000		
2 ⅞	PDPAWL-287	0.157 x 2 ⅞", w/ 1" washer	100	1,000		



PDPAWL

This model available in mechanically galvanized finish (PDPAWL-287MG).

Fasteners for Powder-Actuated Tools

0.300"-Headed Fasteners with 0.157" Shank Diameter – 10-Pin Collation

Length (in.)	Model No.	Description	Pack Qty.	Carton Qty.	Compatible Tools	
					Simpson Strong-Tie	Others
½	PDPAS-50	0.157 x ½"	100	1,000	PTP-27SMAGR PT-27LMAGR	DX-460 MAG and most other low-velocity magazine tools
½ knurled	PDPAS-50K	0.157 x ½" knurl	100	1,000		
⅝ knurled	PDPAS-62K	0.157 x ⅝" knurl	100	1,000		
¾	PDPAS-75	0.157 x ¾"	100	1,000		
1	PDPAS-100	0.157 x 1"	100	1,000		
1¼	PDPAS-125	0.157 x 1¼"	100	1,000		
1½	PDPAS-150	0.157 x 1½"	100	1,000		
1⅞	PDPAS-187	0.157 x 1⅞"	100	1,000		
2	PDPAS-200	0.157 x 2"	100	1,000		
2½	PDPAS-250	0.157 x 2½"	100	1,000		
2⅞	PDPAS-287	0.157 x 2⅞"	100	1,000		



PDPAS

0.300"-Headed Tophat Fasteners with 0.157" Shank Diameter

Length (in.)	Model No.	Description	Pack Qty.	Carton Qty.	Compatible Tools	
					Simpson Strong-Tie	Others
½ knurled	PDPAT-50K	0.157 x ½" knurl	100	1,000	PTP-27L PTP-27S PT-27 PT-27HDA PT-22A PT-22GS PT-22P PT-22HA	721, D-60, U-2000 and most other low-velocity tools
⅝ knurled	PDPAT-62K	0.157 x ⅝" knurl	100	1,000		
¾	PDPAT-75	0.157 x ¾"	100	1,000		
1	PDPAT-100	0.157 x 1"	100	1,000		



PDPAT

Pre-Assembled Ceiling Clips – 0.300"-Headed Fasteners with 0.157" Shank Diameter

Length (in.)	Model No.	Description	Pack Qty.	Carton Qty.	Compatible Tools	
					Simpson Strong-Tie	Others
⅞	PCLDPA-87	Ceiling Clip with ⅞" Pin	100	1,000	PTP-27L PTP-27S PT-27 PT22A PT-22GS PT-22P PT-22HA	DX-350 System 1 721 DX-351, DX-460, Ramset Viper, Reamset Viper 4 and most other tools
1⅙	PCLDPA-106	Ceiling Clip with 1⅙" Pin	100	1,000		
1⅝	PCLDPA-131	Ceiling Clip with 1⅝" Pin	100	1,000		
1⅙	PECLDPA-106	Compact Ceiling Clip with 1⅙" Pin	100	1,000		
1⅝	PECLDPA-131	Compact Ceiling Clip with 1⅝" Pin	100	1,000		



PCLDPA



PECLDPA

Threaded Rod Hangers – 0.300" – Headed Fasteners with 0.157" Shank Diameter

Length (in.)	Model No.	Description	Pack Qty.	Carton Qty.	Compatible Tools	
					Simpson Strong-Tie	Others
1⅙, ¼ – 20 Threaded Rod Hanger	PTRHA4-131	0.157 x 1⅙"	50	500	PTP-27L PTP-27S PT-27 PT-22P PT-22A PT-22GS PT-22HA	DX-350 DX-36 DX-35 DX-A40 DX-460
1⅙, ⅜ – 16 Threaded Rod Hanger	PTRHA3-131	0.157 x 1⅙"	50	500		



PTRHA3

C-A-2016 © 2015 SIMPSON STRONG-TIE COMPANY INC.

Direct Fastening

Fasteners for Powder-Actuated Tools

Type-304 Stainless-Steel 0.300"-Headed Fasteners with 0.145" Shank Diameter and 1" Metal Washers*

Length (in.)	Model No.	Pack Qty.	Carton Qty.	Compatible Tools	
				Simpson Strong-Tie	Others
1	PDPWL-1004SS	100	1,000	PTP-27L PTP-27S** PT-27 PT-22P PT-22A PT-22GS PT-22HA	721**, D-60, DX-460, U-2000, System 1, System 3 and most other low-velocity tools
1¼	PDPWL-1254SS	100	1,000		
1½	PDPWL-1504SS	100	1,000		
2	PDPWL-2004SS	100	1,000		

*Washers are Type-304 Stainless-Steel
**Up to 2"



PDPWL-SS

0.300"-Headed Fasteners with 0.145" Shank Diameter and 1 7/16" Metal Washers

Length (in.)	Model No.	Pack Qty.	Carton Qty.	Compatible Tools	
				Simpson Strong-Tie	Others
1	PINW-100	50	500	PTP-27L PT-27 PT-22P PT-22A PT-22GS PT-22HA	721, D-60, U-2000, System 1, System 3 and most other low-velocity tools
1¼	PINW-125	50	500		
1½	PINW-150	50	500		
2¼	PINW-225	50	500		
2½	PINW-250	50	500		
3	PINW-300	50	500		



PINW

0.300"-Headed Fasteners with 0.145" Shank Diameter and 1 3/8" Plastic White Washers

Length (in.)	Model No.	Pack Qty.	Carton Qty.	Compatible Tools	
				Simpson Strong-Tie	Others
1	PINWP-100W	50	500	PTP-27L PT-27 PT-22P PT-22A PT-22GS PT-22HA	721*, D-60, DX-460, U-2000, System 1, System 3 and most other low-velocity tools
1¼	PINWP-125W	50	500		
1½	PINWP-150W	50	500		
1¾	PINWP-175W	50	500		
2	PINWP-200W	50	500		
2½	PINWP-250W	50	500		
3	PINWP-300W	50	500		

*Up to 2½"



PINWP

Direct Fastening

Fasteners for Powder-Actuated Tools

Highway Basket Clips – 0.300"-Headed Fasteners with 0.145" Shank Diameter

Description	Model No.	Pack Qty.	Carton Qty.	Compatible Tools	
				Simpson Strong-Tie	Others
Clip with 1½" Pin	PHBC-150	100	1,000	PTP-27L, PT-27 PT-22P, PT-22A PT-22GS PT-22HA	DX-A41, Autofast
Clip with 2" Pin	PHBC-200	100	1,000		
Clip with 2½" Pin	PHBC-250	50	1,000		



Pre-Assembled BX Cable Straps and Conduit Straps – 0.300"-Headed Fasteners with 0.145" Shank Diameter

Description	Model No.	Pack Qty.	Carton Qty.	Compatible Tools	
				Simpson Strong-Tie	Others
BX Cable Strap with 1" Pin	PBXDP-100	100	1,000	PTP-27L PTP-27S PT-27 PT-22P PT-22A PT-22GS PT-22HA	D-60, 721, System 1, System 3, DX-350 and most other tools
Conduit Clip ½" EMT with 1" Pin	PCC50-DP100	100	1,000		
Conduit Clip ¾" EMT with 1" Pin	PCC75-DP100	50	500		
Conduit Clip 1" EMT with 1" Pin	PCC100-DP100	50	500		



¼" – 20 Threaded Studs*

Length (in.)	Model No.	Pack Qty.	Carton Qty.	Compatible Tools	
				Simpson Strong-Tie	Others
¼ - 20 Knurled (T-½, S-½)	PSLV4-5050K	100	1,000	PTP-27 PTP-27L PT-27 PT-22A PT-22GS PT-22HA	Most low-velocity tools
¼ - 20 (T-½, S-¾)	PSLV4-5075	100	1,000		
¼ - 20 (T-½, S-1)	PSLV4-50100	100	1,000		
¼ - 20 (T-½, S-1¼)	PSLV4-50125	100	1,000		
¼ - 20 (T-¾, S-¾)	PSLV4-7575	100	1,000		
¼ - 20 Knurled (T-¾, S-½)	PSLV4-7550K	100	1,000		
¼ - 20 (T-¾, S-1)	PSLV4-75100	100	1,000		
¼ - 20 (T-¾, S-1¼)	PSLV4-75125	100	1,000		
¼ - 20 (T-1, S-1)	PSLV4-100100	100	1,000		
¼ - 20 Knurled (T-1¼, S-½)	PSLV4-12550K	100	1,000		
¼ - 20 (T-1¼, S-1¼)	PSLV4-125125	100	1,000		



*Shank diameter is 0.150". NOTE: T = thread length, S = shank length.

Fasteners for Powder-Actuated Tools

3/8" – 16 Threaded Studs* (Factory Mutual Listing-see below)

Length (in.)	Model No.	Pack Qty.	Carton Qty.	Compatible Tools	
				Simpson Strong-Tie	Others
3/8 - 16 Knurled (T-1 1/4, S-3/4)	PSLV3-12575K	100	1,000	PT-27HDA	DX-600 and most other 3/8" barrel tools
3/8 - 16 (T-1 1/4, S-1)	PSLV3-125100	100	1,000		
3/8 - 16 (T-1 1/4, S-1 1/4)	PSLV3-125125**	100	1,000		

*Shank diameter is 0.205". NOTE: T = thread length, S = shank length.

**Factory Mutual Listing 3031724



PSLV3



Metric Fasteners

8mm-Headed Fasteners with 3.68mm Shank Diameter

Length (in.)	Model No.	Pack Qty.	Carton Qty.	Compatible Tools	
				Simpson Strong-Tie	Others
1/2 Knurled	PHN-14K	100	1,000	PTP-27L PTP-27S** PT-27 PT-22P** PT-22A PT-22GS PT-22HA*	DX-350 DX-36 DX-400E DX-A40 DX-460 DX-A41 System 1 DX-351 and 8mm tools
5/8 Knurled	PHN-16K	100	1,000		
3/4 Knurled	PHN-19K	100	1,000		
7/8	PHN-22	100	1,000		
1	PHN-27	100	1,000		
1 1/4	PHN-32	100	1,000		
1 1/2	PHN-37	100	1,000		
1 5/8	PHN-42	100	1,000		
1 7/8	PHN-47	100	1,000		
2	PHN-52	100	1,000		
2 1/4	PHN-57	100	1,000		
2 1/2	PHN-62	100	1,000		
2 7/8	PHN-72	100	1,000		

*Up to 2 1/2"

**Up to 1 1/2"



PHN

Fasteners for Powder-Actuated Tools

Metric Fasteners

8mm-Headed Fasteners with 3.68mm Shank Diameter and 1" Metal Washers

Length (in.)	Model No.	Pack Qty.	Carton Qty.	Compatible Tools	
				Simpson Strong-Tie	Others
1	PHNW-27	100	1,000	PTP-27L PTP-27S* PT-27 PT-22P PT-22A PT-22GS PT-22HA	DX-350 DX-36 DX-400E DX-A40 DX-A41 DX-460 System1 DX-351 and 8mm tools
1 ¼	PHNW-32	100	1,000		
1 ½	PHNW-37	100	1,000		
1 ¾	PHNW-42	100	1,000		
1 ⅞	PHNW-47	100	1,000		
2	PHNW-52	100	1,000		
2 ¼	PHNW-57	100	1,000		
2 ½	PHNW-62	100	1,000		
2 ⅞	PHNW-72	100	1,000		

*Up to 2"



PHNW

8mm-Headed Tophat Fasteners with 3.68mm Shank Diameter

Length (in.)	Model No.	Pack Qty.	Carton Qty.	Compatible Tools	
				Simpson Strong-Tie	Others
5/8 Knurled	PHNT-16K	100	1,000	PTP-27 PTP-27L PTP-27S PT-27 PT-22P PT-22A PT-22GS PT-22HA	DX-35 DX-350 DX-460 and most 8mm tools
¾ Knurled	PHNT-19K	100	1,000		
7/8	PHNT-22	100	1,000		
1	PHNT-27	100	1,000		



PHNT

Direct Fastening

Fasteners for Powder-Actuated Tools

Concrete Forming Pin – 0.187" -Headed with 0.145" Shank Diameter

Length (in.)	Model No.	Pack Qty.	Carton Qty.	Compatible Tools	
				Simpson Strong-Tie	Others
3/16 X 2 1/2 Concrete Forming Pin	PKP-250	100	1,000	PTP-27L, PT-27 PT-22P, PT-22A PT-22GS, PT-22HA	DX-Series and 8mm tools

Note: Lengths in inches are for reference only and may not be exact.



PKP

Miscellaneous

1/4"-Headed Hammer Drive Fastener with 3/8" Metal Washer

Length (in.)	Model No.	Pack Qty.	Carton Qty.	Compatible Tools	
				Simpson Strong-Tie	Others
3/4	PHD-75	100	1,000	PHT-38	HT-38, R-260, R-375, XL-143 and other hammer drive tools
1	PHD-100	100	1,000		
1 1/4	PHD-125	100	1,000		



PHD

Manual Hammer Tool

(not for use with powder loads)



PHT-38

Warning: Do not use powder loads with this tool. This is a hammer drive tool only. Use of powder loads with this tool may result in injury or death.

Direct Fastening

Powder-Actuated Tool Repair and Maintenance Kits

Tool	Kit Model No.	Description	Contents
PT-27	PT-27PK1	Normal wear part replacement kit	5 Shear Clips (Part No. PT-301011)
			1 Annular Spring (Part No. PT-301014)
			1 Piston Stop (Part No. PT-301012)
			3 Ball Bearings (Part No. PT-301013)
			1 Piston (Part No. PT-301903)
			2 Piston Rings (Part No. PT-301208)
			1 Nosepiece (Part No. PT-301010)
All	PT-MK1	Tool cleaning kit	1 Cleaning Brush - Wire (Part No. BRUSH 125)
			1 Cleaning Brush 3/4" Diameter (Part No. BRUSH 25)
			1 Cleaning Brush 1/4" Diameter (Part No. BRUSH 75)
			1 PAT Tool Lubricant – 4 oz. spray bottle (Part No. PT-MTL4.0)
			(1) 1/8" Hex Wrench (Part No. MW-18)
			(1) 3/16" Hex Wrench (Part No. MW-316)
All	PT-MTL2.0	Tool lubricant	(1) 5mm Hex Wrench (Part No. MW-5)
			2 oz. spray bottle

Gas- and Powder-Actuated Pins Design Information – Concrete

PAT and Gas-Actuated Fasteners — Allowable Tension Loads in Normal-Weight Concrete



Direct Fastening Type	Model No.	Shank Diameter In. (mm)	Minimum Penetration In. (mm)	Minimum Edge Distance In. (mm)	Minimum Spacing In. (mm)	Allowable Tension Load — lb. (kN)						
						f _c ≥ 2,000 psi (13.8 MPa) Concrete	f _c ≥ 2,500 psi (17.2 MPa) Concrete	f _c ≥ 3,000 psi (20.7 MPa) Concrete	f _c ≥ 4,000 psi (27.6 MPa) Concrete	f _c ≥ 5,000 psi (34.5 MPa) Concrete	f _c ≥ 6,000 psi (41.3 MPa) Concrete	
Powder Actuated	PDPA PDPAT PDDAW PDDAWL	0.157 (4.0)	3/4 (19)	3.5 (89)	5 (127)	—	110 (0.49)	110 (0.49)	110 (0.49)	—	110 (0.49)	
			1 (25)	3.5 (89)	5 (127)	—	210 (0.93)	240 (1.07)	310 (1.38)	—	160 (0.71)	
			1 1/4 (32)	3.5 (89)	5 (127)	—	320 (1.42)	340 (1.51)	380 (1.69)	—	365 (1.62)	
			1 1/2 (38)	3.5 (89)	5 (127)	—	375 (1.67)	400 (1.78)	450 (2.00)	—	465 (2.07)	
	PDPWL-SS	0.145 (3.7)	1 (25)	3 (76)	4 (102)	60 (0.27)	—	—	—	—	—	
	PHN	0.145 (3.7)	3/4 (19)	3 (76)	4 (102)	—	—	—	60 (0.27)	—	—	
			1 (25)	3 (76)	4 (102)	45 (0.20)	70 (0.31)	100 (0.44)	150 (0.67)	—	150 (0.67)	
			1 1/4 (32)	3 (76)	4 (102)	140 (0.62)	195 (0.87)	255 (1.13)	370 (1.65)	—	370 (1.65)	
	PSLV3	0.205 (5.2)	1 1/4 (32)	4 (102)	6 (152)	—	260 (1.16)	—	—	—	—	
	Gas Actuated	GDP	0.106 (2.7)	5/8 (16)	3 (76)	4 (102)	25 (0.11)	25 (0.11)	30 (0.13)	45 (0.20)	45 (0.20)	—
				3/4 (19)	3 (76)	4 (102)	30 (0.13)	30 (0.13)	30 (0.13)	30 (0.13)	30 (0.13)	—
		GW-75 GW-100 GTH	0.125 (3.2)	5/8 (16)	3 (76)	4 (102)	60 (0.27)	65 (0.29)	70 (0.31)	95 (0.42)	—	—
3/4 (19)				3 (76)	4 (102)	85 (0.38)	95 (0.42)	105 (0.47)	190 (0.85)	—	—	

1. The fasteners must not be driven until the concrete has reached the designated minimum compressive strength.
2. Minimum concrete thickness must be three times the fastener embedment into the concrete.
3. The allowable tension and shear values are only for the fastener in the concrete. Members connected to the concrete must be investigated in accordance with accepted design criteria.

PAT and Gas-Actuated Fasteners — Allowable Shear Loads in Normal-Weight Concrete



Direct Fastening Type	Model No.	Shank Diameter In. (mm)	Minimum Penetration In. (mm)	Minimum Edge Distance In. (mm)	Minimum Spacing In. (mm)	Allowable Shear Load — lb. (kN)						
						f _c ≥ 2,000 psi (13.8 MPa) Concrete	f _c ≥ 2,500 psi (17.2 MPa) Concrete	f _c ≥ 3,000 psi (20.7 MPa) Concrete	f _c ≥ 4,000 psi (27.6 MPa) Concrete	f _c ≥ 5,000 psi (34.5 MPa) Concrete	f _c ≥ 6,000 psi (41.3 MPa) Concrete	
Powder Actuated	PDPA PDPAT PDDAW PDDAWL	0.157 (4.0)	3/4 (19)	3.5 (89)	5 (127)	—	120 (0.53)	125 (0.56)	135 (0.60)	—	130 (0.58)	
			1 (25)	3.5 (89)	5 (127)	—	285 (1.27)	290 (1.29)	310 (1.38)	—	350 (1.56)	
			1 1/4 (32)	3.5 (89)	5 (127)	—	360 (1.60)	380 (1.69)	420 (1.87)	—	390 (1.73)	
			1 1/2 (38)	3.5 (89)	5 (127)	—	405 (1.80)	430 (1.91)	485 (2.16)	—	495 (2.20)	
	PDPWL-SS	0.145 (3.7)	1 (25)	3 (76)	4 (102)	195 (0.87)	—	—	—	—	—	
	PHN	0.145 (3.7)	3/4 (19)	3 (76)	4 (102)	—	—	—	95 (0.42)	—	—	
			1 (25)	3 (76)	4 (102)	120 (0.53)	140 (0.62)	165 (0.73)	205 (0.91)	—	205 (0.91)	
			1 1/4 (32)	3 (76)	4 (102)	265 (1.18)	265 (1.18)	265 (1.18)	265 (1.18)	—	265 (1.18)	
	Gas Actuated	GDP	0.106 (2.7)	5/8 (16)	3 (76)	4 (102)	25 (0.11)	25 (0.11)	25 (0.11)	25 (0.11)	25 (0.11)	—
				3/4 (19)	3 (76)	4 (102)	45 (0.20)	50 (0.22)	55 (0.24)	75 (0.33)	75 (0.33)	—
		GW-75 GW-100 GTH	0.125 (3.2)	5/8 (16)	3 (76)	4 (102)	55 (0.24)	60 (0.27)	65 (0.29)	95 (0.42)	—	—
				3/4 (19)	3 (76)	4 (102)	120 (0.53)	135 (0.60)	145 (0.64)	215 (0.96)	—	—

1. The fasteners must not be driven until the concrete has reached the designated minimum compressive strength.
2. Minimum concrete thickness must be three times the fastener embedment into the concrete.
3. The allowable tension and shear values are only for the fastener in the concrete. Members connected to the concrete must be investigated in accordance with accepted design criteria.

* See page 12 for an explanation of the load table icons.

Gas- and Powder-Actuated Pins Design Information – Concrete



PAT and Gas-Actuated Assemblies — Allowable Tension Loads in Normal-Weight Concrete

Direct Fastening Type	Model No.	Shank Diameter In. (mm)	Minimum Penetration In. (mm)	Minimum Edge Distance In. (mm)	Minimum Spacing In. (mm)	Allowable Tension Load — lb. (kN)					
						f _c ≥ 2,000 psi (13.8 MPa) Concrete	f _c ≥ 2,500 psi (17.2 MPa) Concrete	f _c ≥ 3,000 psi (20.7 MPa) Concrete	f _c ≥ 4,000 psi (27.6 MPa) Concrete	f _c ≥ 5,000 psi (34.5 MPa) Concrete	f _c ≥ 6,000 psi (41.3 MPa) Concrete
Powder Actuated	PCLDPA	0.157 (4.0)	1 (25)	3.5 (89)	5 (102)	175 (0.78)	—	—	180 (0.80)	—	190 (0.85)
			1¼ (32)	3.5 (89)	5 (102)	210 (0.93)	—	—	210 (0.93)	—	190 (0.85)
	PECLDPA	0.157 (4.0)	1 (25)	3.5 (89)	5 (102)	180 (0.80)	—	—	155 (0.69)	—	180 (0.80)
			1¼ (32)	3.5 (89)	5 (102)	185 (0.82)	—	—	220 (0.98)	—	190 (0.85)
Gas Actuated	GRH25 GRH37	0.125 (3.2)	¾ (19)	3 (76)	4 (102)	—	85 (0.38)	115 (0.51)	160 (0.71)	165 (0.73)	165 (0.73)
			GAC	¾ (19)	3 (76)	4 (102)	—	105 (0.47)	120 (0.53)	150 (0.67)	170 (0.76)

1. The fasteners must not be driven until the concrete has reached the designated minimum compressive strength.
2. Minimum concrete thickness must be three times the fastener embedment into the concrete.
3. The allowable tension values are only for the fastener in the concrete. Members connected to the concrete must be investigated in accordance with accepted design criteria.

Direct Fastening



PAT and Gas-Actuated Assemblies — Allowable Oblique Loads in Normal-Weight Concrete

Direct Fastening Type	Model No.	Shank Diameter In. (mm)	Minimum Penetration In. (mm)	Minimum Edge Distance In. (mm)	Minimum Spacing In. (mm)	Allowable Oblique Load — lb. (kN)					
						f _c ≥ 2,000 psi (13.8 MPa) Concrete	f _c ≥ 2,500 psi (17.2 MPa) Concrete	f _c ≥ 3,000 psi (20.7 MPa) Concrete	f _c ≥ 4,000 psi (27.6 MPa) Concrete	f _c ≥ 5,000 psi (34.5 MPa) Concrete	f _c ≥ 6,000 psi (41.3 MPa) Concrete
Powder Actuated	PCLDPA	0.157 (4.0)	1 (25)	3.5 (89)	5 (102)	255 (1.13)	—	—	240 (1.07)	—	245 (1.09)
			1¼ (32)	3.5 (89)	5 (102)	250 (1.11)	—	—	265 (1.18)	—	265 (1.18)
	PECLDPA	0.157 (4.0)	1 (25)	3.5 (89)	5 (102)	225 (1.00)	—	—	230 (1.02)	—	255 (1.13)
Gas Actuated	GAC	0.125 (3.2)	¾ (19)	3 (76)	4 (102)	—	130 (0.58)	135 (0.60)	145 (0.64)	155 (0.69)	175 (0.78)

1. The fasteners must not be driven until the concrete has reached the designated minimum compressive strength.
2. Minimum concrete thickness must be three times the fastener embedment into the concrete.
3. The allowable oblique values are only for the fastener in the concrete. Members connected to the concrete must be investigated in accordance with accepted design criteria.
4. Oblique load direction is 45° from the concrete member surface.

* See page 12 for an explanation of the load table icons.

Gas- and Powder-Actuated Pins Design Information – Concrete

PAT Fasteners — Allowable Tension and Shear Loads for Attachment of Wood Sill Plates to Normal-Weight Concrete

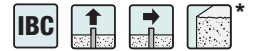

Direct Fastening Type	Model No.	Overall Length In. (mm)	Nominal Head Diameter In. (mm)	Shank Diameter In. (mm)	Washer Thickness In. (mm)	Washer Bearing Area In ² (mm ²)	f' _c ≥ 2,000 psi (13.8 MPa)		f' _c ≥ 2,500 psi (17.2 MPa)	
							Allow. Tension Load lb. (kN)	Allow. Shear Load lb. (kN)	Allow. Tension Load lb. (kN)	Allow. Shear Load lb. (kN)
Powder Actuated	PDPAW-287	2 ⁷ / ₈ (73)	0.300 (7.6)	0.157 (4.0)	0.070 (1.8)	0.424 (274)	—	—	200 (0.89)	205 (0.91)
	PDPAWL-287 PDPAWL-287MG	2 ⁷ / ₈ (73)	0.300 (7.6)	0.157 (4.0)	0.070 (1.8)	0.767 (495)	—	—	200 (0.89)	205 (0.91)
	PHNW-72	2 ⁷ / ₈ (73)	0.315 (8.0)	0.145 (3.7)	0.070 (1.8)	0.770 (497)	125 (0.56)	150 (0.67)	—	—

1. The fasteners must not be driven until the concrete has reached the designated minimum compressive strength.
2. Minimum concrete thickness must be three times the fastener embedment into the concrete.
3. The allowable tension and shear values are only for the fastener in the concrete. Members connected to the concrete must be investigated in accordance with accepted design criteria.
4. Minimum concrete edge distance is 1³/₄ inches.
5. Only mechanically galvanized fasteners may be used to attach preservative-treated wood to concrete.
6. Minimum spacing shall be 4" on center.

Spacing of PAT Fasteners for Attachment of Wood Sill Plates to Normal-Weight Concrete



Direct Fastening Type	Model No.	Overall Length In. (mm)	Nominal Head Diameter In. (mm)	Shank Diameter In. (mm)	Maximum Spacing In. (mm)
					Interior Nonstructural Walls ²
Powder Actuated	PHNW-72 ³	2 ⁷ / ₈ (73)	0.315 (8.0)	0.145 (3.7)	36 (914)
	PDPAW-287 ⁴ PDPAWL-287 ⁴ PDPAWL-287MG ⁴	2 ⁷ / ₈ (73)	0.300 (7.6)	0.157 (4.0)	48 (1219)

1. Spacings are based upon the attachment of 2-inch (nominal thickness) wood sill plates, with specific gravity of 0.50 or greater, to concrete floor slabs or footings.
2. All walls shall have fasteners placed at 6 inches from ends of sill plates, with maximum spacing as shown in the table.
3. Fasteners shall not be driven until the concrete has reached a compressive strength of 2,000 psi. Minimum edge distance is 1³/₄ inches.
4. Fasteners shall not be driven until the concrete has reached a compressive strength of 2,500 psi. Minimum edge distance is 1³/₄ inches.
5. The maximum horizontal transverse load on the wall shall be 5 psf.
6. The maximum wall height shall be 14 feet.
7. For exterior walls and interior structural walls, this table is not applicable and allowable loads must be used.
8. Walls shall be laterally supported at the top and the bottom.
9. Minimum spacing shall be 4" on center.
10. Only mechanically galvanized fasteners may be used to attach preservative-treated wood to concrete.

* See page 12 for an explanation of the load table icons.

Gas- and Powder-Actuated Pins Design Information – Concrete

PAT and Gas-Actuated Fasteners —
Allowable Tension Loads in Sand-Lightweight Concrete over Metal Deck



Direct Fastening Type	Model No.	Shank Diameter In. (mm)	Minimum Penetration In. (mm)	Allowable Tension Load — lb. (kN)				
				Installed in Concrete ⁴	Installed Thru. 3" "W" Deck with 3 1/4" Concrete Fill ⁵	Installed Thru. 3" "W" Deck with 2 1/4" Concrete Fill ⁶	Installed Thru. 1.5" "B" Deck with 2 1/4" Concrete Fill ⁷	Installed Thru. 1.5" "B" Deck with 2" Concrete Fill ⁸
				$f'_c \geq 3,000$ psi (20.7 MPa) Concrete				
Powder Actuated	PDDPA PDDPAT PDDPAW PDDPAWL	0.157 (4.0)	3/4 (19)	85 (0.38)	105 (0.47)	—	—	160 (0.71)
			1 (25)	150 (0.67)	145 (0.64)	—	—	210 (0.93)
			1 1/4 (32)	320 (1.42)	170 (0.76)	—	—	265 (1.18)
			1 1/2 (38)	385 (1.71)	325 (1.45)	—	—	—
	PHNT	0.145 (3.7)	7/8 (22)	185 (0.82)	165 (0.73)	—	—	—
	PSLV3	0.205 (5.2)	1 1/4 (32)	—	225 (1.00)	—	—	—
	PSLV4	0.150 (3.8)	1 (25)	—	80 (0.36)	—	—	—
Gas Actuated	GDP	0.106 (2.7)	5/8 (16)	75 (0.33)	—	60 (0.27)	65 (0.29)	—
			3/4 (19)	105 (0.47)	—	60 (0.27)	130 (0.58)	—
	GW-75 GW-100 GTH	0.125 (3.2)	5/8 (16)	60 (0.27)	—	35 (0.16)	—	—
			3/4 (19)	115 (0.51)	—	55 (0.24)	—	—

1. The fastener shall not be driven until the concrete has reached the designated compressive strength.
2. The allowable tension values are for the fastener only. Members connected to the steel must be investigated separately in accordance with accepted design criteria.
3. Metal deck must be minimum 20 gauge and have a minimum yield strength of 38,000 psi.
4. The minimum fastener spacing is 4". The minimum edge distances are 3 1/2" and 3" for powder-actuated fasteners and gas-actuated fasteners, respectively.
5. The fastener shall be installed minimum 1 1/2" from the edge of flute and 4" from the end of the deck. The minimum fastener spacing is 4".
6. The fastener shall be installed minimum 1" from the edge of flute and 3" from the end of the deck. The minimum fastener spacing is 4". For GW and GTH fasteners, the fastener must be a minimum of 1 1/8" from the edge of flute.
7. The fastener shall be installed minimum 7/8" from the edge of flute. For inverted 1.5" "B" deck configuration, the fastener must be a minimum of 1" from the edge of flute. Fastener must be installed minimum 3" from the end of the deck. The minimum fastener spacing is 4".
8. The fastener shall be installed minimum 7/8" from the edge of flute and 4" from the end of the deck. The minimum fastener spacing is 4".

* See page 12 for an explanation of the load table icons.

Gas- and Powder-Actuated Pins Design Information – Concrete

PAT and Gas-Actuated Fasteners —

Allowable Shear Loads in Sand-Lightweight Concrete over Metal Deck



Direct Fastening Type	Model No.	Shank Diameter In. (mm)	Minimum Penetration In. (mm)	Allowable Shear Load — lb. (kN)				
				Installed in Concrete ⁹	Installed Thru. 3" "W" Deck with 3/4" Concrete Fill ⁶	Installed Thru. 3" "W" Deck with 2 1/4" Concrete Fill ⁶	Installed Thru. 1.5" "B" Deck with 2 1/4" Concrete Fill ⁷	Installed Thru. 1.5" "B" Deck with 2" Concrete Fill ⁸
				$f_c \geq 3,000$ psi (20.7 MPa) Concrete				
Powder Actuated	PDPA PDPAT PDPAW PDPAWL	0.157 (4.0)	3/4 (19)	105 (0.47)	280 (1.25)	—	—	275 (1.22)
			1 (25)	225 (1.00)	280 (1.25)	—	—	370 (1.65)
			1 1/4 (32)	420 (1.87)	320 (1.42)	—	—	460 (2.05)
			1 1/2 (38)	455 (2.02)	520 (2.31)	—	—	—
	PHNT	0.145 (3.7)	7/8 (22)	275 (1.22)	400 (1.78)	—	—	—
Gas Actuated	GDP	0.106 (2.7)	5/8 (16)	35 (0.16)	—	180 (0.80)	195 (0.87)	—
			3/4 (19)	140 (0.62)	—	180 (0.80)	270 (1.20)	—
	GW-75 GW-100 GTH	0.125 (3.2)	5/8 (16)	110 (0.49)	—	215 (0.96)	—	—
			3/4 (19)	130 (0.58)	—	235 (1.05)	—	—

1. The fastener shall not be driven until the concrete has reached the designated compressive strength.
2. The allowable shear values are for the fastener only. Members connected to the steel must be investigated separately in accordance with accepted design criteria.
3. Metal deck must be minimum 20 gauge and have a minimum yield strength of 38,000 psi.
4. Shear values are for loads applied toward edge of flute.
5. The fastener shall be installed minimum 1 1/2" from the edge of flute and 4" from the end of the deck. The minimum fastener spacing is 4".
6. The fastener shall be installed minimum 1" from the edge of flute and 3" from the end of the deck. The minimum fastener spacing is 4". For GW and GTH fasteners, the fastener must be a minimum of 1 1/8" from the edge of flute.
7. The fastener shall be installed minimum 7/8" from the edge of flute. For inverted 1.5" "B" deck configuration, the fastener must be a minimum of 1" from the edge of flute. Fastener must be installed minimum 3" from the end of the deck. The minimum fastener spacing is 4".
8. The fastener shall be installed minimum 7/8" from the edge of flute and 4" from the end of the deck. The minimum fastener spacing is 4".
9. The minimum fastener spacing is 4". The minimum edge distances are 3 1/2" and 3" for powder-actuated fasteners and gas-actuated fasteners, respectively.

* See page 12 for an explanation of the load table icons.

Gas- and Powder-Actuated Pins Design Information – Concrete

PAT and Gas-Actuated Assemblies –
Allowable Tension Loads in Sand-Lightweight Concrete over Metal Deck



Direct Fastening Type	Model No.	Shank Diameter In. (mm)	Minimum Penetration In. (mm)	Allowable Tension Load — lb. (kN)			
				Installed Thru. 3" "W" Deck with 2½" Concrete Fill ⁴	Installed Thru. 3" "W" Deck with 2¼" Concrete Fill ⁵	Installed Thru. 1.5" "B" Deck with 2¼" Concrete Fill ⁶	Installed Thru. 1.5" "B" Deck with 2" Concrete Fill ⁷
				$f'_c \geq 3,000$ psi (20.7 MPa) Concrete			
Powder Actuated	PTRHA3 PTRHA4	0.157 (4.0)	1 (25)	160 (0.71)	—	—	175 (0.78)
			1¼ (32)	160 (0.71)	—	—	175 (0.78)
	PCLDPA	0.157 (4.0)	1 (25)	140 (0.62)	—	—	160 (0.71)
			1¼ (32)	160 (0.71)	—	—	180 (0.80)
	PECDLPA	0.157 (4.0)	1 (25)	120 (0.53)	—	—	135 (0.60)
	Gas Actuated	GRH25 GRH37	0.125 (3.2)	¾ (19)	—	95 (0.42)	95 (0.42)
GAC		0.125 (3.2)	¾ (19)	—	105 (0.47)	90 (0.40)	—

- The fastener shall not be driven until the concrete has reached the designated compressive strength.
- The allowable tension values are for the fastener only. Members connected to the steel must be investigated separately in accordance with accepted design criteria.
- Metal deck must be minimum 20 gauge and have a minimum yield strength of 38,000 psi.
- The fastener shall be installed minimum 1½" from the edge of flute and 4" from the end of the deck. The minimum fastener spacing is 4".
- The fastener shall be installed minimum 1" from the edge of flute and 3" from the end of the deck. The minimum fastener spacing is 4".
- The fastener shall be installed minimum 7/8" from the edge of flute and 3" from the end of the deck. The minimum fastener spacing is 4".
- The fastener shall be installed minimum 7/8" from the edge of flute and 4" from the end of the deck. The minimum fastener spacing is 4".

Direct Fastening

PAT and Gas-Actuated Assemblies –
Allowable Oblique Loads in Sand-Lightweight Concrete over Metal Deck



Direct Fastening Type	Model No.	Shank Diameter In. (mm)	Minimum Penetration In. (mm)	Allowable Oblique Load — lb. (kN)			
				Installed Thru. 3" "W" Deck with 2½" Concrete Fill ⁴	Installed Thru. 3" "W" Deck with 2¼" Concrete Fill ⁵	Installed Thru. 1.5" "B" Deck with 2¼" Concrete Fill ⁶	Installed Thru. 1.5" "B" Deck with 2" Concrete Fill ⁷
				$f'_c \geq 3,000$ psi (20.7 MPa) Concrete			
Powder Actuated	PCLDPA	0.157 (4.0)	1 (25)	175 (0.78)	—	—	240 (1.07)
			1¼ (32)	185 (0.82)	—	—	280 (1.25)
	PECDLPA	0.157 (4.0)	1 (25)	145 (0.64)	—	—	175 (0.78)
Gas Actuated	GAC	0.125 (3.2)	¾ (19)	—	120 (0.53)	90 (0.40)	—

- The fastener shall not be driven until the concrete has reached the designated compressive strength.
- The allowable oblique values are for the fastener only. Members connected to the steel must be investigated separately in accordance with accepted design criteria.
- Metal deck must be minimum 20 gauge and have a minimum yield strength of 38,000 psi.
- The fastener shall be installed minimum 1½" from the edge of flute and 4" from the end of the deck. The minimum fastener spacing is 4".
- The fastener shall be installed minimum 1" from the edge of flute and 3" from the end of the deck. The minimum fastener spacing is 4".
- The fastener shall be installed minimum 7/8" from the edge of flute and 3" from the end of the deck. The minimum fastener spacing is 4".
- The fastener shall be installed minimum 7/8" from the edge of flute and 4" from the end of the deck. The minimum fastener spacing is 4".
- Oblique load direction is 45° from the concrete member surface.

* See page 12 for an explanation of the load table icons.

Gas- and Powder-Actuated Pins Design Information – Concrete

PAT and Gas-Actuated Fasteners – Allowable Tension and Shear Loads in Hollow CMU



Direct Fastening Type	Model No.	Shank Diameter In. (mm)	Minimum Penetration In. (mm)	Minimum Edge Distance In. (mm)	Minimum Spacing In. (mm)	8-inch Hollow CMU Loads Based on CMU Strength	
						Tension Load	Shear Load
						Allowable lb. (kN)	Allowable lb. (kN)
Powder Actuated	PDPA PDPAT PDPAW PDPAWL	0.157 (4.0)	1¾ (44)	4 (102)	8 (203)	125 ¹ (0.56)	210 ¹ (0.93)
Gas Actuated	GDP	0.106 (2.7)	¾ (16)	3 (76)	8 (203)	35 ¹ (0.16)	50 ¹ (0.22)
	GW-75 GW-100 GTH	0.125 3.2)	¾ (16)	3 (76)	8 (203)	55 ² (0.24)	65 ² (0.29)

1. Values for 8-inch-thick lightweight concrete masonry units conforming to ASTM C90. Values for 8-inch-thick medium-weight concrete masonry units conforming to ASTM C90.

2. Minimum penetration is measured from the outside face of the concrete masonry unit. No more than one fastener may be installed in an individual hollow CMU cell.

PAT and Gas-Actuated Fasteners – Allowable Tension Loads in Steel¹



Direct Fastening Type	Model No.	Shank Diameter ¹⁰ In. (mm)	Minimum Edge Distance In. (mm)	Minimum Spacing In. (mm)	Minimum Steel Strength ³	Allowable Tension Load — lb. (kN)					
						½" Thick Steel	¾" Thick Steel	¼" Thick Steel	⅜" Thick Steel	½" Thick Steel	¾" Thick Steel
Powder Actuated	PDPA PDPAT PDPAW PDPAWL	0.157 (4.0)	0.5 (13)	1 (25)	ASTM A36	—	260 (1.16)	370 (1.65)	380 ⁷ (1.69)	530 ⁷ (2.36)	195 ⁴ (0.87)
			0.5 (13)	1 (25)	ASTM A572 Gr. 50 or ASTM A992	—	305 (1.36)	335 (1.49)	355 ⁷ (1.58)	485 ⁵ (2.16)	170 ⁶ (0.76)
	PHN	0.145 (3.7)	0.5 (13)	1 (25)	ASTM A36	—	155 (0.69)	—	—	—	—
	PHN Knurled ¹¹	0.145 (3.7)	0.5 (13)	1 (25)	ASTM A36	—	155 (0.69)	440 (1.96)	—	—	—
	PHNT	0.145 (3.7)	0.5 (13)	1 (25)	ASTM A36	40 (0.18)	50 (0.22)	250 (1.11)	—	—	—
	PSLV3	0.205 (5.2)	1 (25)	1½ (38)	ASTM A36	—	270 (1.20)	680 (3.02)	—	—	—
	PSLV3-12575K	0.205 (5.2)	1 (25)	1½ (38)	ASTM A36	—	270 (1.20)	870 (3.87)	—	—	—
PSLV4	0.150 (3.8)	0.5 (13)	1 (25)	ASTM A36	—	200 (0.89)	420 (1.87)	—	—	—	
Gas Actuated	GDP	0.106 (2.7)	0.5 (13)	1 (25)	ASTM A36	125 (0.56)	210 (0.93)	220 (0.98)	—	—	—
			0.5 (13)	1 (25)	ASTM A572 Gr. 50 or ASTM A992	—	225 (1.00)	185 (0.82)	—	—	—
	GDPS	0.118/0.102 (3.0/2.6)	0.5 (13)	1 (25)	ASTM A36	—	95 (0.42)	170 (0.76)	165 ⁸ (0.73)	145 ⁸ (0.64)	—
			0.5 (13)	1 (25)	ASTM A572 Gr. 50 or ASTM A992	—	110 (0.49)	170 (0.76)	155 ⁸ (0.69)	—	—
	GW-50	0.128/0.110 (3.3/2.8)	0.5 (13)	1 (25)	ASTM A36	—	225 (1.00)	275 (1.22)	245 ⁹ (1.09)	—	—
0.5 (13)			1 (25)	ASTM A572 Gr. 50 or ASTM A992	—	240 (1.07)	215 ⁹ (0.96)	280 ⁹ (1.25)	—	—	

- The entire pointed portion of the fastener must penetrate through the steel to obtain the tabulated values, unless otherwise indicated.
- The allowable tension values are for the fastener only. Members connected to the steel must be investigated separately in accordance with accepted design criteria.
- Steel strength must comply with the minimum requirements of ASTM A 36 ($F_y = 36$ ksi, $F_u = 58$ ksi), ASTM A 572, Grade 50 ($F_y = 50$ ksi, $F_u = 65$ ksi), or ASTM A992 ($F_y = 50$ ksi, $F_u = 65$ ksi).
- Based upon minimum penetration depth of 0.46" (11.7 mm).

- Based upon minimum penetration depth of 0.58" (14.7 mm).
- Based upon minimum penetration depth of 0.36" (9.1 mm).
- The fastener must be driven to where the point of the fastener penetrates through the steel.
- Based upon minimum penetration depth of 0.35" (8.9 mm).
- Based upon minimum penetration depth of 0.25" (6.4 mm).
- For stepped shank fasteners: (Diameter of shank above the step)/(Diameter of shank below the step.)
- PHN-16K or longer.

* See page 12 for an explanation of the load table icons.

Gas- and Powder-Actuated Pins Design Information – Concrete



PAT and GAS Fasteners — Allowable Shear Loads in Steel¹

Direct Fastening Type	Model No.	Shank Diameter ¹⁰ In. (mm)	Minimum Edge Distance In. (mm)	Minimum Spacing In. (mm)	Minimum Steel Strength ³	Allowable Shear Load — lb. (kN)					
						1/8" Thick Steel	3/16" Thick Steel	1/4" Thick Steel	3/8" Thick Steel	1/2" Thick Steel	3/4" Thick Steel
Powder Actuated	PDPA, PDPAT, PDPAWL, PDPAWL	0.157 (4.0)	0.5 (13)	1 (25)	ASTM A36	—	410 (1.82)	365 (1.62)	385 ⁷ (1.71)	385 ⁷ (1.71)	325 ⁴ (1.45)
					ASTM A572 Gr. 50 or ASTM A992	—	420 (1.87)	365 (1.62)	290 ⁷ (1.29)	275 ⁷ (1.22)	275 ⁷ (1.22)
	PHN	0.145 (3.7)	0.5 (13)	1 (25)	ASTM A36	—	395 (1.76)	—	—	—	—
	PHN Knurled ¹¹	0.145 (3.7)	0.5 (13)	1 (25)	ASTM A36	—	395 (1.76)	—	—	—	—
	PHNT	0.145 (3.7)	0.5 (13)	1 (25)	ASTM A36	440 (1.96)	620 (2.76)	620 (2.76)	—	—	—
	PSLV3	0.205 (5.2)	1 (25)	1 1/2 (38)	ASTM A36	—	770 (3.43)	1,120 (4.98)	—	—	—
	PSLV3-12575K	0.205 (5.2)	1 (25)	1 1/2 (38)	ASTM A36	—	930 (4.14)	1,130 (5.03)	—	—	—
PSLV4	0.150 (3.8)	0.5 (13)	1 (25)	ASTM A36	—	630 (2.80)	690 (3.07)	—	—	—	
Gas Actuated	GDP	0.106 (2.7)	0.5 (13)	1 (25)	ASTM A36	285 (1.27)	225 (1.00)	205 (0.91)	—	—	—
			0.5 (13)	1 (25)	ASTM A572 Gr. 50 or ASTM A992	—	250 (1.11)	145 (0.64)	—	—	—
	GDPS	0.118/0.102 (3.0/2.6)	0.5 (13)	1 (25)	ASTM A36	—	180 (0.80)	265 (1.18)	225 ⁸ (1.00)	225 ⁸ (1.00)	—
			0.5 (13)	1 (25)	ASTM A572 Gr. 50 or ASTM A992	—	205 (0.91)	305 (1.36)	205 ⁸ (0.91)	—	—
	GW-50	0.128/0.110 (3.3/2.8)	0.5 (13)	1 (25)	ASTM A36	—	400 (1.78)	345 (1.53)	310 ⁹ (1.38)	—	—
			0.5 (13)	1 (25)	ASTM A572 Gr. 50 or ASTM A992	—	380 (1.69)	325 ⁹ (1.45)	350 ⁹ (1.56)	—	—

Direct Fastening

- The entire pointed portion of the fastener must penetrate through the steel to obtain the tabulated values, unless otherwise indicated.
- The allowable shear values are for the fastener only. Members connected to the steel must be investigated separately in accordance with accepted design criteria.
- Steel strength must comply with the minimum requirements of ASTM A 36 ($F_y = 36$ ksi, $F_u = 58$ ksi), ASTM A 572, Grade 50 ($F_y = 50$ ksi, $F_u = 65$ ksi), or ASTM A992 ($F_y = 50$ ksi, $F_u = 65$ ksi).
- Based upon minimum penetration depth of 0.46" (11.7 mm).
- Based upon minimum penetration depth of 0.58" (14.7 mm).
- Based upon minimum penetration depth of 0.36" (9.1 mm).
- The fastener must be driven to where the point of the fastener penetrates through the steel.
- Based upon minimum penetration depth of 0.35" (8.9 mm).
- Based upon minimum penetration depth of 0.25" (6.4 mm).
- For stepped shank fasteners: (Diameter of shank above the step)/(Diameter of shank below the step).
- PHN-16K or longer.

* See page 12 for an explanation of the load table icons.

Gas- and Powder-Actuated Pins Design Information – Concrete

Spiral Knurl Pin Allowable Tension and Shear Loads in Cold-Formed Steel Studs, 33 ksi Minimum Yield Strength    *

Model No.	Shank Diameter in. (mm)	Minimum Edge Dist. in. (mm)	Minimum Spacing in. (mm)	Designation Thickness mils (gauge)	Allowable Loads	
					Tension lb. (kN)	Shear lb. (kN)
GDPSK-138	0.109 (2.8)	13/16 (2.1)	4 (102)	33 (20)	30 (0.13)	70 (0.31)
				43 (18)	48 (0.21)	89 (0.40)

1. Entire pointed portion of the fastener must penetrate through the steel to obtain tabulated values.
2. The allowable tension and shear values are for the fastener only. Members connected to the steel must be investigated separately in accordance with accepted design criteria.
3. Fastener is to be installed in the center of the stud flange.

Spiral Knurl Pin Allowable Tension and Shear Loads in Cold-Formed Steel Studs, 50 ksi Minimum Yield Strength    *

Model No.	Shank Diameter in. (mm)	Minimum Edge Dist. in. (mm)	Minimum Spacing in. (mm)	Designation Thickness mils (gauge)	Allowable Loads	
					Tension lb. (kN)	Shear lb. (kN)
GDPSK-138	0.109 (2.8)	13/16 (2.1)	4 (102)	54 (16)	92 (0.41)	150 (0.67)
				68 (14)	73 (0.32)	218 (0.97)

1. Entire pointed portion of the fastener must penetrate through the steel to obtain tabulated values.
2. The allowable tension and shear values are for the fastener only. Members connected to the steel must be investigated separately in accordance with accepted design criteria.
3. Fastener is to be installed in the center of the stud flange.

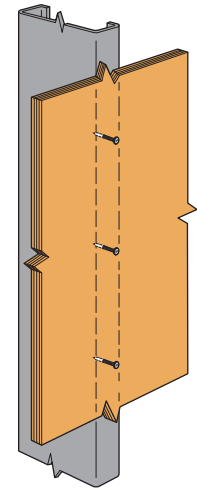

Typical GDPSK Installation

Direct Fastening

PHN Fasteners Attaching Light-Gauge Steel Channels — Allowable Shear Loads in Normal-Weight Concrete    *

Model No.	Shank Diameter in. (mm)	Minimum Penetration in. (mm)	Light Gauge Steel Channel Thickness gauge	Allowable Shear Load lb. (kN)
				$f'_c \geq 2,000$ psi (13.8 MPa) Concrete
PHN	0.145 (3.7)	7/8 (22)	20	160 (0.71)
			18	135 (0.60)

1. The fasteners shall not be driven until the concrete has reached the designated compressive strength. Minimum concrete thickness is three times the faster embedment into the concrete.

* See page 12 for an explanation of the load table icons.

Restoration Solutions



Simpson Strong-Tie offers a line of products designed for structural and architectural rehabilitation of concrete and masonry.

Our restoration solutions provide reliable, easy-to-use products for a variety of applications, including structural restoration, pick-proof sealing and water-intrusion prevention.



ETI Injection Epoxy

ETI injection epoxies are two-component, high-solids formulations for the injection into cracks in concrete. Dispensed through a static mixing nozzle using either a manual, battery-powered or a pneumatic dispensing tool, these epoxies provide a waterproof, high strength (structural) repair.

Features

- Bonds chemically to concrete, providing structural repair (meets the requirements of ASTM C 881 for structural repair epoxy)
- Formulated for maximum penetration under pressure (all viscosities)
- Seals out moisture, protecting rebar in the concrete from corrosion and flooring from moisture damage
- Reliable mixing and ratio control when used with the Simpson Strong-Tie® Optimix® static mixing nozzle (included with cartridge)
- Suitable for pressure injection or gravity-feed applications
- Non-shrink material resists oils, salts and mild chemicals
- Final product color: ETI-SLV – dark purple / black; ETI-LV – amber; ETI-GV – gray



ETI-SLV

ETI-SLV Super-Low-Viscosity Epoxy

- Super-low viscosity (350 cP) repairs hairline cracks (0.002") and cracks up to ¼" in width
- Penetrates smallest cracks
- Meets or exceeds AASHTO M-235 and ASTM C881 Type I and IV, Grade 1, Class B and C

ETI-LV Low-Viscosity Epoxy

- Repairs fine to medium cracks ¼" to ¼" in width
- Offers low surface tension to effectively penetrate narrow cracks
- Approved under NSF/ANSI standard 61
- Meets or exceeds AASHTO M-235 and ASTM C881 Type I and IV, Grade 1, Class C

ETI-GV Gel-Viscosity Epoxy

- Gel-viscosity (non-sag) epoxy repairs medium cracks ¾" – ¼" in width
- Decreases in viscosity under pressure, increasing flow
- Suitable for use as pick-proof sealant around doors, windows and fixtures
- Meets or exceeds AASHTO M-235 and ASTM C881 Type I and IV, Grade 3, Class C

Application Considerations

- Suitable for repairing non-moving cracks in concrete walls, floors, slabs, columns and beams.
- ETI can be used to inject cracks in damp or wet conditions (non-seeping or non-leaking conditions only) with excellent results.
- Apply to concrete 60°F or above. For best results, warm material to 60°F or above prior to application.
- Mixed material in nozzle and injection fitting hardens in 15 minutes (ETI-SLV), and in 60 minutes (ET-LV, ETI-GV) at temperatures of 40°F or above

Shelf Life: 24 months from date of manufacture in unopened cartridge

Storage Conditions: For best results, store between 45°F and 95°F

Injection Instructions: See pages 293–297.



ETI-LV



ETI-GV

ETI Injection Epoxy

Property	Test Method	ETI-SLV Results*	ETI-LV Results*	ETI-GV Results*
Viscosity (75°F)	ASTM D2556	350 cP	1,790 cP	Non-sag gel
Bond Strength (moist cure) @ 2 days	ASTM C882	3,100 psi	2,500 psi	1,110 psi
	@ 14 days	3,900 psi	2,530 psi	3,990 psi
Tensile Strength	ASTM D638	10,200 psi	7,470 psi	—
Tensile Elongation at Break	ASTM D638	2.1%	4.8%	—
Compressive Yield Strength	ASTM D695	16,500 psi	12,500 psi	11,600 psi
Compressive Modulus	ASTM D695	569,000 psi	342,000 psi	403,000 psi
Heat Deflection Temperature	ASTM D648	140°F	130°F	131°F
Water Absorption (24-hour soak)	ASTM D570	0.25%	0.76%	0.58%
Linear Coefficient of Shrinkage	ASTM D2556	0.0035	0.0040	0.0000
Gel Time (60-gram mass)	ASTM C881	16 min.	68 min.	135 min.
Volatile Organic Compounds (VOC)	EPA Method 24 ASTM D2369	23 g/L	6 g/L	4 g/L
Initial Cure	—	24 hours	24 hours	24 hours
Mixing Ratio by Volume (Part A:Part B)	—	2:1	1:1	1:1

*Material and curing conditions: 73 ± 2°F

ETI Cartridge System¹

Model No.	Capacity ounces (cubic in.)	Dispensing Tool	Mixing Nozzle
ETISLV	16.5 (29.8)	EDT22S	EMN022 (included)
ETILV22	22 (39.7)		
ETIGV22			

1. Bulk containers also available. Contact Simpson Strong-Tie for details.
2. Use only appropriate Simpson Strong-Tie® mixing nozzles in accordance with Simpson Strong-Tie instructions. Modification or improper use of mixing nozzle may impair epoxy performance.
3. EDT22s tool must be configured for 2:1 cartridge ratio.

Crack-Pac® Injection Epoxy

The Crack-Pac® injection epoxy is designed to repair cracks in concrete ranging from 1/64" to 1/4" wide in concrete walls, floors, slabs, columns and beams. The mixed adhesive has the viscosity of a light oil and a low surface tension, allowing it to penetrate fine to medium-width cracks in dry, damp or wet conditions with excellent results. Resin is contained in the cartridge and hardener is contained in the nozzle.

Features

- Dispenses with a standard caulking tool, no special dispensing tool needed
- Clean and easy to mix
- Seals out moisture, protecting rebar in the concrete from corrosion and flooring from moisture damage
- Chemically bonds with the concrete to restore strength
- Non-shrink material resistant to oils, salts and mild chemicals
- Meets the requirements of AASHTO M-235 and ASTM C881, Type IV, Grade 1, Class C

Application Considerations

- Suitable for repair of cracks ranging from 1/64" to 1/4" wide in concrete walls, floors, slabs, columns and beams
- Can be used to inject cracks in dry, damp or wet conditions with excellent results. Not for use in actively leaking cracks.
- In order for components to mix properly, the resin and hardener must be conditioned to 60°F–80°F before mixing

Shelf Life: 24 months from date of manufacture, unopened

Storage Conditions: For best results, store between 45°F and 95°F

Injection Instructions: See pages 293–297.

Complementary Products

Crack-Pac® injection epoxy is also available in the Crack-Pac Injection Kit. (ETIPAC10KT). The kit includes everything needed to pressure inject approximately 8 lineal feet of cracks (assumes a concrete thickness of 4" and 1/16" crack width).

- 2 Crack-Pac cartridge/nozzle sets
- 12 E-Z-Click injection ports
- 2 E-Z-Click injection fittings with 12" tubing
- 1 pint of ETR paste-over epoxy (8 oz. of resin + 8 oz. of hardener)
- 4 disposable wood paste-over applicators
- 1 pair latex gloves
- Installation video



Crack-Pac® Injection Epoxy (ETIPAC10)
 Dispensing Systems: U.S. Patents 6,737,000 and 6,896,001 B2



Crack-Pac® Kit (ETIPAC10KT)



Crack-Pac® Kit Components

Complementary Products



Crack-Pac® Injection Epoxy
 9 oz. Cartridge



CDT10S
 Manual dispensing tool for acrylic adhesive dispensing cartridges (page 128)

Crack-Pac® Injection Epoxy

Property	Test Method	Results*
Viscosity	ASTM D2556	1,400 cP
Bond Strength (moist cure) @ 2 days	ASTM C882	2,010 psi
@ 14 days	ASTM C882	3,830 psi
Tensile Strength	ASTM D638	5,860 psi
Tensile Elongation at Break	ASTM D638	14.0%
Compressive Yield Strength	ASTM D695	11,300 psi
Compressive Modulus	ASTM D695	319,000 psi
Flexural Strength	ASTM D790	8,020 psi
Water Absorption (24-hour soak)	ASTM D570	0.08%
Linear Coefficient of Shrinkage	ASTM D2556	0.0020
Gel Time (60-gram mass)	ASTM C881	16 min.
Full, Mixed Cartridge	—	30 min.
Volatile Organic Compounds (VOC)	EPA Method 24 ASTM D2369	7 g/L
Initial Cure	—	24 hours
Mixing Ratio by Volume (Part A:Part B)	—	8:1

*Material and curing conditions: 73 ± 2°F

Crack-Pac® Cartridge System

Model No.	Capacity ounces (cubic in.)	Cartridge Type	Carton Quantity	Dispensing Tool
CPFH09	9 (16.2)	single	12	CDT10S or standard caulking tool
CPFH09KT	18 (32.4)	single	2 (kits)	

Crack-Pac® Flex-H₂O™ Polyurethane Crack Sealer

The Crack-Pac® Flex-H₂O™ polyurethane injection resin seals leaking cracks, voids or fractures from 1/32" to 1/4" wide in concrete or solid masonry. Designed to perform in applications where water is seeping or mildly leaking from the crack, the polyurethane is packaged in the cartridge and an accelerator is packaged in the nozzle. When the resin encounters water as it is injected into the crack, it becomes an expanding foam that provides a flexible seal in leaking and non-leaking cracks.

Features

- Can be dispensed with a standard caulking tool
- Can also be used on dry cracks if water is introduced to affected area
- Can be used with a reduced amount or without accelerator to slow down reaction time
- Expands to fill voids and seal the affected area
- Fast reacting – reaction begins within 1 minute after exposure to moisture; expansion may be completed within 3 minutes (depending on the amount of moisture and the ambient temperature)
- 20:1 expansion ratio (unrestricted rise) means less material needed

Application Considerations

- Suitable for sealing cracks ranging from 1/32" to 1/4" wide in concrete and solid masonry.
- Suitable for repair of cracks in dry, damp and wet conditions with excellent results. Designed to perform in applications where water is seeping or mildly leaking from the crack.
- In order for components to mix properly, the resin and hardener must be conditioned to 60°F–90°F before mixing.

Shelf Life: 12 months from the date of manufacture, unopened

Usage Temperature: 60°F to 90°F

Storage Conditions: For best results, store in a dry area between 45°F and 90°F. Product is very moisture sensitive.

Installation Instructions: See pages 293–297.

Accessories: See page 289 for information on mixing nozzles and for crack repair accessories.

Additional Components Needed for Crack Repair

Condition	Paste-Over Material	Ports
Dry Crack	ETR or CIP-F*	EIP-EZA Flush-Mount
Wet Crack		
Seeping Crack	Hydraulic Cement	EIPX-EZ Drill-In
Mildly Leaking Crack		

*CIP-F requires EIP-EZA port.



Crack-Pac® Flex-H₂O™ Crack Sealer

Dispensing System:
U.S. Patents
6,737,000 and
6,896,001 B2

Crack-Pac® Flex-H₂O™ Cartridge System

Model No.	Capacity Ounces	Carton Quantity
CPFH09	9	12
CPFH09KT	18	2 (kits)

Crack-Pac® Flex-H₂O™ Bulk Packaging

Model No.	Description	Capacity
FH05*	Flex-H ₂ O Resin	5 Gallons
	Flex-H ₂ O Catalyst	16 Ounces

*For standard reaction time, use a 30:1 resin: catalyst ratio. For a faster reaction time, add more catalyst, for a slower reaction time, use less.

Complementary Products



Crack-Pac® Flex-H₂O™ Kit (CPFH09KT)

- 2 Crack-Pac Flex-H₂O cartridge/nozzle sets
- 12 E-Z-Click injection ports
- 2 E-Z-Click injection fittings with 12" tubing



Crack-Pac® Flex-H₂O™ Kit Components

- 1 pint of ETR paste-over epoxy (8 oz. of resin + 8 oz. of hardener)
- 4 disposable wood paste-over applicators
- 1 pair latex gloves

Crack Repair Accessories



E-Z-Click
Ports and Injection Fitting



E-Z-Click
Injection Fitting



EMN22
Optimix®
Mixing Nozzle



EIPX-EZ
Corner Mount/
Drilled-In Port



EIP-EZA
Flush-Mount Port



ETR16



CIP-F

Crack Injection Paste-Over in Cartridge Delivery System

Model No.	Capacity ounces	Carton Quantity
CIP-F	22	10

Crack Repair Accessories Product Data

Description	Model No.	Package Qty.	Carton Qty. (ea.)
6 Optimix® mixing nozzles for ETI epoxies (6 1/2" long, 3/8" square). Includes retaining nuts. ¹	EMN022-RP6	6	30 (5 Packs)
100 E-Z-Click flush-mount injection ports and 1 E-Z-Click injection fitting	EIP-EZA	—	100
20 E-Z-Click flush-mount injection ports and 1 E-Z-Click injection fitting (compatible with all Simpson Strong-Tie paste-overs)	EIP-EZAKT	—	5 Kits
20 E-Z-Click corner mount/drilled-in injection ports ²	EIPX-EZ-RP20	20	100 (5 Packs)
20 E-Z-Click corner mount/drilled-in injection ports and 1 E-Z-Click injection fitting ²	EIPX-EZKT	—	5 Kits
E-Z-Click injection fitting	EIF-EZ	1	10
ETR Kit containing 1 8-oz. canister of resin and 1 8-oz. canister of hardener	ETR16	—	4 Kits

1. Use only an appropriate Simpson Strong-Tie® mixing nozzle in accordance with Simpson Strong-Tie instructions. Modification or improper use of mixing nozzle may impair epoxy performance.
2. EIPX intended for use as a surface mount port in corners and a drilled-in port on flat surfaces. All accessories compatible with ETI-SLV, ETI-LV and ETI-GV epoxies.

Detailed information on the full line of Simpson Strong-Tie® manual and pneumatic dispensing tools is available on pages 128–129.

Heli-Tie™ Helical Wall Tie

The Heli-Tie™ is a stainless-steel helical tie used to anchor building façades to structural members or to stabilize multiple-wythe brick walls.

The helical design allows the tie to be driven quickly and easily into a predrilled pilot hole (or embedded into mortar joints in new construction) to provide a mechanical connection between a masonry façade and its backup material or between multiple wythes of brick. As it is driven, the fins of the tie undercut the masonry to provide an expansion-free anchorage that will withstand tension and compression loads.

The Heli-Tie wall tie is installed using a proprietary setting tool that is used with an SDS-PLUS shank rotohammer to drive and countersink the tie. Heli-Tie wall ties perform in concrete and masonry as well as wood and steel studs.



Heli-Tie™ Helical Wall Tie

U.S. Patent 7,269,987

Features

- Installs quickly and easily — with the rotohammer in hammer mode, the tie installs faster than competitive products.
- Provides an inconspicuous repair that preserves the appearance of the building. After installation, the tie is countersunk up to ½" below the surface, allowing the tie location to be patched.
- Larger core diameter provides higher torsional capacity, resulting in less deflection due to “uncoiling” under load.
- Fractionally sized anchor — no metric drill bits required.
- Patented manufacturing process results in a more uniform helix along the entire tie, allowing easier driving and better interlock with the substrate.

Material: Type-304 stainless steel (Type 316 available by special order—contact Simpson Strong-Tie for details)

Test Criteria: CSA A370

Installation

- Drill pilot hole through the façade material and into the backup material to the specified embedment depth + 1" using appropriate drill bit(s). Drill should be in rotation-only mode when drilling into soft masonry or into hollow backing material.
- Position blue end of the Heli-Tie™ fastener in the installation tool and insert the tie into the pilot hole.
- With the SDS-PLUS rotohammer in hammer mode, drive the tie until the tip of the installation tool enters the exterior surface of the masonry and countersinks the tie below the surface. Patch the hole in the façade.



Installation Sequence

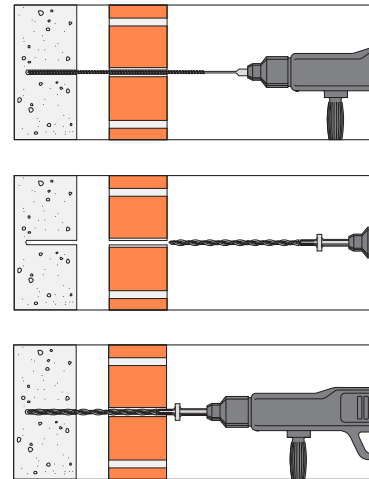

Special-order lengths are also available; contact Simpson Strong-Tie for details.

Heli-Tie™ Product Data

Size (in.)	Model No.	Drill Bit Dia. (in.)	Quantity	
			Box	Carton
¾ x 7	HELI37700A	7/32 or ¼	50	400
¾ x 8	HELI37800A		50	400
¾ x 9	HELI37900A		50	400
¾ x 10	HELI371000A		50	200
¾ x 11	HELI371100A		50	200
¾ x 12	HELI371200A		50	200
¾ x 14	HELI371400A		50	200
¾ x 16	HELI371600A		50	200
¾ x 18	HELI371800A		50	200
¾ x 20	HELI372000A		50	200



HELITOOL37A

Heli-Tie™ Fastener Installation Tool — Model HELITOOL37A

Required for correct installation of Heli-Tie wall ties. Speeds up installation and automatically countersinks the tie into the façade material.

Heli-Tie™ Design Information

Guide Tension Loads in Various Base Materials

Size in. (mm)	Base Material	Anchor Location	Drill Bit Dia. in.	Min. Embed. Depth in. (mm)	Tension Load ¹			
					Ultimate ² lb. (kN)	Load at Max. Permitted Displ. ³ lb. (kN)	Standard Deviation lb. (kN)	
3/8 (9.0)	Solid Brick ⁴	Mortar Bed Joint	7/32	3 (76)	570 (2.5)	240 (1.1)	79 (0.4)	
			1/4		365 (1.6)	130 (0.6)	46 (0.2)	
		Brick Face	7/32		1,310 (5.8)	565 (2.5)	84 (0.4)	
			1/4		815 (3.6)	350 (1.6)	60 (0.3)	
	Hollow Brick ⁵	Mortar Bed Joint	7/32		530 (2.4)	285 (1.3)	79 (0.4)	
			1/4		775 (3.4)	405 (1.8)	47 (0.2)	
		Brick Face	7/32		510 (2.3)	185 (0.8)	20 (0.1)	
			1/4		1,170 (5.2)	405 (1.8)	79 (0.4)	
	Grout-Filled CMU ⁶	Center of Face Shell	7/32	2 3/4 (70)	830 (3.7)	350 (1.6)	60 (0.3)	
			1/4		1,160 (5.2)	440 (2.0)	56 (0.2)	
		Web	7/32		810 (3.6)	330 (1.5)	100 (0.4)	
			1/4		720 (3.2)	320 (1.4)	71 (0.3)	
		Mortar Bed Joint	7/32		530 (2.4)	205 (0.9)	58 (0.3)	
			1/4		790 (3.5)	305 (1.4)	56 (0.2)	
		Hollow CMU ⁷	Center of Face Shell		7/32	505 (2.2)	255 (1.1)	46 (0.2)
					1/4	1,200 (5.3)	445 (2.0)	50 (0.2)
	Web		7/32	675 (3.0)	385 (1.7)	96 (0.4)		
			1/4	880 (3.9)	410 (1.8)	76 (0.3)		
	Normal-Weight Concrete ⁸	-	7/32	1 3/4 (44)	990 (4.4)	380 (1.7)	96 (0.4)	
			1/4	2 3/4 (70)	590 (2.6)	370 (1.6)	24 (0.1)	
	2x4 Wood Stud ^{9,11}	Center of Thin Edge	7/32	2 3/4 (70)	450 (2.0)	260 (1.2)	6 (0.0)	
			1/4		200 (0.9)	120 (0.5)	8 (0.0)	
	Metal Stud ^{10,11}	Center of Flange	7/32	1 (25)	155 (0.7)	95 (0.4)	2 (0.0)	
			1/4		200 (0.9)	120 (0.5)	8 (0.0)	

Caution: Loads are guide values based on laboratory testing. On-site testing shall be performed for verification of capacity since base material quality can vary widely.

1. Tabulated loads are guide values based on laboratory testing. Onsite testing shall be performed for verification of capacity since base material quality can vary widely.
2. Ultimate load is average load at failure of the base material. Heli-Tie™ fastener average ultimate steel strength is 3,885 pounds and does not govern.
3. Load at maximum permitted displacement is average load at displacement of 0.157 inches (4 mm). The designer shall apply a suitable factor of safety to these numbers to derive allowable service loads.
4. Solid brick values for nominal 4-inch-wide solid brick conforming to ASTM C62/C216, Grade SW, Type N mortar is prepared in accordance with IBC Section 2103.8.
5. Hollow brick values for nominal 4-inch-wide hollow brick conforming to ASTM C216/C652, Grade SW, Type HBS, Class H40V. Mortar is prepared in accordance with IBC Section 2103.8.
6. Grout-filled CMU values for 8-inch-wide lightweight, medium-weight and normal-weight concrete masonry units. The masonry units must be fully grouted. Values for 8-inch-wide concrete masonry units (CMU) with a minimum specified compressive strength of masonry, f'_m , at 28 days is 1,500 psi.
7. Hollow CMU values for 8-inch-wide lightweight, medium-weight and normal-weight concrete masonry units.
8. Normal-weight concrete values for concrete with minimum specified compressive strength of 2,500 psi.
9. 2x4 wood stud values for nominal 2x4 Spruce-Pine-Fir.
10. Metal stud values for 20-gauge C-shape metal stud.
11. For new construction. Anchor one end of tie into backup material. Embed other end into veneer mortar joint. Not for retrofits due to difficulty of locating center of 2x4 or metal stud flange.

Compression (Buckling) Loads¹

Size in. (mm)	Unsupported Length in. (mm)	Ultimate Compression Load ¹ lb. (kN)
3/8 (9.0)	1 (25)	1,905 (8.5)
	2 (50)	1,310 (5.8)
	4 (100)	980 (4.4)
	6 (150)	785 (3.5)

1. The Designer shall apply a suitable factor of safety to these numbers to derive allowable service loads.



HELITEST37A

HELIKEY37A

Heli-Tie™ Wall Tie Tension Tester - Model HELITEST37A

Recommended equipment for onsite testing to accurately determine load values in any specific structure, the Heli-Tie wall tie tension tester features a key specifically designed to grip the Heli-Tie fastener and provide accurate results. Replacement test keys sold separately (Model HELIKEY37A).

Heli-Tie™ Helical Stitching Tie

The Simpson Strong-Tie® Heli-Tie™ helical stitching tie provides a unique solution to the preservation and repair of damaged brick and masonry structures. Ties are grouted into existing masonry to repair cracks and increase strength with minimum disturbance. Made of Type-304 stainless steel, the Heli-Tie stitching tie features radial fins formed on the steel wire via cold rolling process, increasing the tensile strength of the tie.



HELIST254000

Features

- Helical design distributes loads uniformly over a large surface area
- Installs into the mortar joint to provide an inconspicuous repair and preserve the appearance of the structure
- Type-304 stainless steel offers superior corrosion resistance to original reinforcement
- Patented manufacturing process results in consistent, uniform helix configuration (U.S. Patent 7,269,987)
- Batch number printed on each tie for easy identification and inspection

HELIST254000: ¼" x 40" stitching tie

Material: Type-304 stainless steel

Ordering Information: Sold in tubes of 10

Installation Instructions

- Chase bed joint 20" on either side of the affected area to a depth of approximately 1 ¼" with a rotary grinding wheel. Vertical spacing of installation sites should be 12" for red brick or "every other course" for concrete masonry units.
- Clear bed joint of all loose debris.
- Mix non-shrink repair grout or mortar per product instructions and place into the prepared bed joint, filling the void to approximately two-thirds of its depth. Simpson Strong-Tie FX-263 repair mortar may be used.
- Embed the tie at one-half the depth of the void. Trowel displaced grout to fully encapsulate the tie.
- Fill any remaining void and vertical cracks with non-shrink repair grout or other repair mortar to conceal repair site.

Installation Sequence

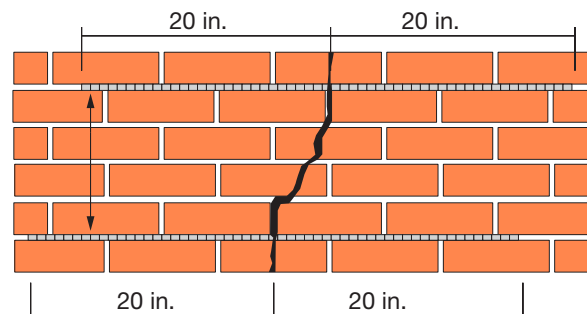
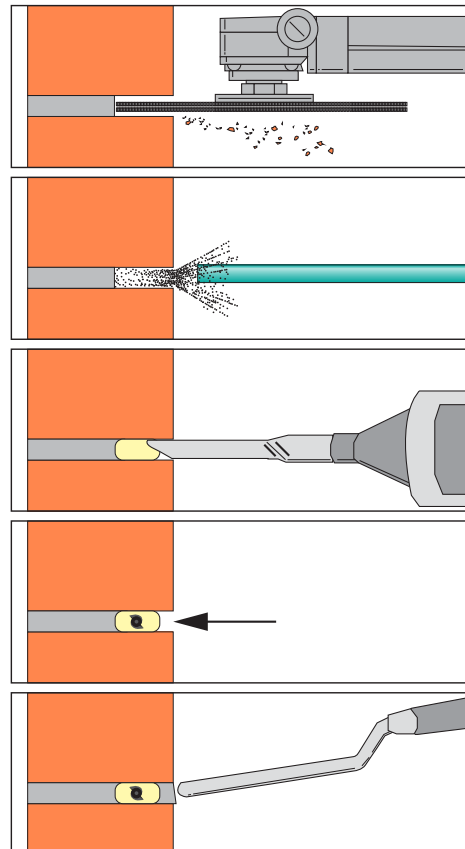

Crack Injection Guide

Important: These instructions are intended as recommended guidelines. Due to the variability of field conditions, selection of the proper material for the intended application and installation is the sole responsibility of the applicator.

Epoxy injection is an economical method of repairing non-moving cracks in concrete walls, slabs, columns and piers and is capable of restoring the concrete to its pre-cracked strength. Prior to doing any injection it is necessary to determine the cause of the crack. If the source of cracking has not been determined and remedied, the concrete may crack again.

Materials

- ETI-SLV for repair of hairline cracks (0.002") and those up to 1/4" in width.
- ETI-LV for repair of fine to medium-width cracks (Suggested width range: 1/64"–1/4").
- ETI-GV for repair of medium-width cracks (Suggested width range: 3/32"–1/4")
- Crack-Pac® injection epoxy for repair of fine to medium non-structural cracks (Suggested width range: 1/64"–1/4")
- CIP-F and ETR are recommended for paste-over of crack surface and installation of injection ports. ET-HP, EDOT™, ETR or SET adhesives may also be used as a substitute. (SET is the only paste-over epoxy approved for NSF/ANSI Standard 61.)
- E-Z-Click™ injection ports, fittings and other suitable accessories.

Estimating Guide for Epoxy Crack Injection

Width of Crack (in.)	Concrete Thickness (in.)	Approx. Coverage per 22 oz. Cartridge (linear ft.)	Approx. Coverage per 16.5 oz. Cartridge (linear ft.)	Approx. Coverage per 9 oz. Cartridge (linear ft.)
1/64	4	47.7	35.7	18.4
	6	31.8	23.8	12.3
	8	23.8	17.9	9.2
	10	19.1	14.3	7.4
1/32	4	23.8	17.9	9.2
	6	15.9	11.9	6.1
	8	11.9	8.9	4.6
	10	9.5	7.1	3.7
1/16	4	11.9	8.9	4.6
	6	7.9	6.0	3.1
	8	6.0	4.5	2.3
	10	4.8	3.6	1.8
1/8	4	6.0	4.5	2.3
	6	4.0	3.0	1.5
	8	3.0	2.2	1.2
	10	2.4	1.8	0.9
3/16	4	4.0	3.0	1.5
	6	2.6	2.0	1.0
	8	2.0	1.5	0.8
	10	1.6	1.2	0.6
1/4	4	3.0	2.2	1.2
	6	2.0	1.5	0.8
	8	1.5	1.1	0.6
	10	1.2	0.9	0.5

Coverage listed is approximate and will vary depending on waste and condition of concrete.

Crack Injection Guide

Preparation of the Crack for Injection

Clean the crack and the surface surrounding it to allow the paste-over to bond to sound concrete. At a minimum, the surface to receive paste-over should be brushed with a wire brush. Oil, grease or other surface contaminant must be removed in order to allow the paste-over to bond properly. Take care not to impact any debris into the crack during cleaning. Using clean, oil-free compressed air, blow out the crack to remove any dust, debris or standing water. Best results will be obtained if the crack is dry at the time of injection. If water is continually seeping from the crack, the flow must be stopped in order for epoxy injection to yield a suitable repair. Other materials such as polyurethane resins may be required to repair an actively leaking crack.

For many applications, additional preparation is necessary in order to seal the crack. Where a surfacing material has been

removed using an acid or chemical solvent, prepare the crack as follows:

1. Using clean, compressed air, blow out any remaining debris and liquid.
2. Remove residue by high-pressure washing or steam cleaning.
3. Blow any remaining water from the crack with clean compressed air.

If a coating, sealant or paint has been applied to the concrete, it must be removed before placing the paste-over epoxy. Under the pressure of injection, these materials may lift and cause a leak. If the surface coating is covering the crack, it may be necessary to route out the opening of the crack in a "V" shape using a grinder in order to get past the surface contamination.

Sealing of the Crack and Attachment of E-Z-Click™ Injection Ports

1. To adhere the port to the concrete, apply a small amount of paste-over around the bottom of the port base (Picture 1). Place the port at one end of the crack and repeat until the entire crack is ported (Picture 2). As a rule of thumb, injection ports should be placed 8" apart along the length of the crack.

Important: Do not allow paste-over to block the port or the crack under it; this is where the injection epoxy must enter the crack.

2. Using a putty knife or other paste-over tool, generously work paste-over along the entire length of the crack (Picture 3). Take care to mound the paste-over around the base of the port to approximately ¼" thick extending 1" out from the base of the port and to work out any holes in the material. It is recommended that the paste-over should be a minimum of ⅜" thick and 1" wide along the crack. Insufficient paste-over will result in leaks under the pressure of injection. If the crack passes completely through the concrete element, seal the back of the crack, if possible. If not, epoxy may be able to run out the back side of the crack, resulting in an ineffective repair.
3. Allow the paste-over to harden before beginning injection. Note: CIP-F and ETR epoxies are fast-cure materials and may harden prematurely if left in a mixed mass on the mixing surface while installing ports. Spreading paste-over into a thin film (approximately ⅛") on the mixing surface will slow curing by allowing the heat from the reaction to dissipate.

Injection Procedure for ETI-SLV, ETI-LV, ETI-GV and Crack-Pac® Injection Epoxy

1. Follow cartridge preparation instructions on the cartridge label. Verify that the material flowing from the Optimix® mixing nozzle is a uniform and consistent color: for ETI-SLV, the mixed product is black; ETI-LV is transparent amber; and ETI-GV is grey. For Crack-Pac® injection epoxy, verify that the mixed material in the cartridge is a transparent amber color.
2. Attach the E-Z-Click™ fitting to the end of the nozzle by pushing the tubing over the barbs at the end of the nozzle. Make sure that all ports are pushed in to the open position.
3. Attach the E-Z-Click™ injection fitting to the first E-Z-Click™ port until it clicks into place. Make sure that the heads of all the ports are pushed in to the open position. In vertical applications, begin injection at the lowest port and work your way up. In a horizontal application, start at one end of the crack and work your way to the other end.
4. Inject epoxy into the first port until it will no longer flow into the crack. If epoxy shows at the next port and the first port still accepts material, close the second port and continue to inject into the first port until it accepts no more epoxy. Continue closing ports where epoxy appears until the first port refuses epoxy. When the first port reaches the point of refusal, brace the base of the port and pull out gently on the head of the port to close it. Pulling too hard may dislodge the port from the surface of the concrete, causing a leak. Depress the metal tab on the head of the E-Z-Click fitting and remove it from the port.
5. Go to the last port where epoxy appeared while injecting the first port, open it, and continue injection at this port. If the epoxy has set up and the port is bonded closed, move to the next clean port and repeat the process until every portion of the crack has refused epoxy.



While this method may appear to leave some ports uninjected, it provides maximum pressure to force the epoxy into the smaller areas of the crack. Moving to the next port as soon as epoxy appears will allow the epoxy to travel along the wider parts of the crack to the next ports rather than force it into the crack before it travels to the next ports.

Crack Injection Guide

INJECTION TIPS

- If using a pneumatic dispensing tool, set the tool at a low setting when beginning injection and increase pressure if necessary to get the epoxy to flow.
- For narrow cracks, it may be necessary to increase the pressure gradually until the epoxy begins to flow. It may also be necessary to wait for a few minutes for the epoxy to fill the crack and travel to the next port.
- If desired, once the injection epoxy has cured, remove the injection ports and paste-over. An epoxy-based paste-over can be removed with a chisel, scraper or grinder. The paste-over can

be simply peeled off if CIP-F is used. Using a heat gun to soften the epoxy is recommended when using a chisel or scraper.

- Mixing nozzles can be used for multiple cartridges as long as the epoxy does not harden in the nozzle. For injection epoxies in side-by-side cartridges, care must be taken to ensure the level of material is the same on both parts of the cartridge. This can be done by checking for air in the cartridge and the positions of the wipers in the back of the cartridge. If the liquid levels are off by more than 1/8", then Step 1 from the injection procedures must be repeated.

TROUBLESHOOTING

Epoxy is flowing into the crack, but not showing up at the next port.

This can indicate that the crack either expands and/or branches off under the surface of the concrete. Continue to inject and fill these voids. In situations where the crack penetrates completely through the concrete element, and the back-side of the concrete element cannot be sealed (e.g., basement walls, or footings with backfill), longer injection time may not force the epoxy to the next port. This most likely indicates that epoxy is running out the unsealed back side of the crack. In this case, the application may require a gel viscosity injection epoxy (ETI-GV) or may not be suitable for epoxy injection repair without excavation and sealing of the back side of the crack.

Epoxy is leaking from the pasted-over crack or around injection ports.

Stop injecting. If using a fast-cure paste-over material (ETR or CIP), wipe off the leaking injection epoxy with a cotton cloth and reapply the paste-over material. Wait approximately 10–15 minutes to allow the epoxy to begin to harden. If the leak is large (e.g., the port broke off of the concrete surface), it is a good idea to wait approximately 30 minutes, or longer as necessary, to allow the paste-over to cure more completely. Check to see that the epoxy is hard before reinjecting, or the paste-over or ports may leak. Another option for small leaks is to clean off the injection epoxy and use paraffin or crayon to seal the holes.

More epoxy is being used than estimated.

This may indicate that the crack either expands or branches off below the surface. Continue to inject and fill these voids. This

may also indicate that epoxy is running out the back side of the crack. If the crack penetrates completely through the concrete element and cannot be sealed, the application may require a gel viscosity injection epoxy (ETI-GV) or may not be suitable for injection repair.

Back pressure is preventing epoxy from flowing. This can indicate several situations:

- The crack is not continuous, and the portion being injected is full. (See above instructions about injection after the port has reached refusal.)
- The port is not aligned over the crack properly.
- The crack is blocked by debris.
- The injection epoxy used has too high a viscosity.
- If the mixing nozzle has been allowed to sit for a few minutes full of epoxy, the material may have hardened in the nozzle. Attach the E-Z-Click™ fitting to a port at another uninjected location on the crack and attempt to inject. If the epoxy still won't flow, chances are the epoxy has hardened in the nozzle. If so, replace the nozzle.

Less epoxy is being used than estimated.

This may indicate that the crack is shallower than originally thought, or the epoxy is not penetrating the crack sufficiently before moving to the next port. Reinject some ports with a lower-viscosity epoxy to see if the crack will take more epoxy. Another option is to heat the epoxy to a temperature of 80–100°F, which will reduce its viscosity and allow it to penetrate into small cracks easier. The epoxy should be heated uniformly; do not overheat cartridge.

Crack Injection Guide

Injection Procedure for Crack-Pac® Flex-H₂O™ Crack Sealer

1. Follow cartridge preparation instructions on the cartridge label. Verify that the material flowing from the nozzle is a uniform green color.
2. Attach the E-Z-Click™ fitting to the end of the nozzle by pushing the tubing over the barbs at the end of the nozzle. Make sure that all ports are pushed into the open position.
3. Attach the E-Z-Click injection fitting to the first E-Z-Click port until it clicks into place. Make sure that the head of the port is pushed into the open position. In vertical applications, begin injection at the lowest port and work your way up. In a horizontal application, start at one end of the crack and work your way to the other end.
4. Inject polyurethane into the first port until material shows at the next port. Remove the E-Z-Click fitting by bracing the base of the port and pulling out gently on the head of the port to close it. Pulling too hard may dislodge the port from the surface of the concrete, causing a leak. Depress the metal tab on the head of the E-Z-Click fitting and remove it from the port.
5. Move to the next port and repeat until all ports have been injected.

Injection Tips for Crack-Pac® Flex-H₂O Crack Sealer

- For narrow cracks, it may be necessary to increase the pressure gradually until the polyurethane begins to flow. It may also be necessary to wait a few minutes for the material to fill the crack and travel to the next port.
- If desired, once the polyurethane has cured, remove the injection ports and paste-over epoxy or hydraulic cement. The paste-over can be removed with a chisel, scraper or grinder.

Troubleshooting for Crack-Pac® Flex-H₂O Crack Sealer

Polyurethane is flowing into the crack, but not showing up at the next port.

This can indicate that either the crack expands and/or branches off under the surface of the concrete. Continue to inject and fill these voids.

Back pressure is preventing polyurethane from flowing.

This can indicate several situations:

- The crack is not continuous and the portion being injected is full.
- The port is not aligned over the crack properly.
- The crack is blocked by debris.

Polyurethane is leaking from the pasted-over crack or around injection ports.

Stop injecting. If using a fast cure paste-over material (ETR or CIP), wipe off the leaking injection epoxy with a cotton cloth and reapply the paste over material. Wait a approximately 10–15

minutes to allow the paste-over to begin to harden. If the leak is large (e.g., the port broke off of the concrete surface), it is a good idea to wait approximately 30 minutes, or longer as necessary, to allow the paste-over to cure more completely. Check to see that the paste-over is hard before reinjecting or the paste-over or ports may leak.

Another option for small leaks is to clean off the injection adhesive and use paraffin or crayon to seal the holes.

More polyurethane is being used than estimated.

This may indicate that the crack either expands or branches off below the surface. Continue to inject and fill these voids.

Less polyurethane is being used than estimated.

This may indicate that the crack is shallower than originally thought, or the polyurethane is not penetrating the crack sufficiently before moving to the next port.

Crack Injection Guide

GRAVITY-FEED PROCEDURE

In some horizontal applications where complete penetration isn't a requirement, cracks can be repaired using the gravity-feed method.

1. Follow cartridge preparation instructions on the cartridge label. Verify that the material flowing from the Optimix® mixing nozzle is a uniform and consistent color: For ETI-SLV, the mixed product is black, while ETI-LV is transparent amber. For Crack-Pac® injection epoxy, verify that the mixed material in the cartridge is a transparent amber color.
2. Starting at one end of the crack, slowly dispense epoxy into the crack, moving along the crack as it fills. It will probably be necessary to do multiple passes in order to fill the crack. It is possible that the epoxy will take some time to run into the crack, and the crack may appear empty several hours after the initial application. Reapply epoxy until the crack is filled.
3. In situations where the crack completely penetrates the member (e.g., concrete slab), the material may continue to run through the crack into the subgrade. It may be possible to use a small amount of coarse, dry sand to act as a barrier for the injection epoxy. Place the sand in the crack to a level no more than ¼" thickness of the member and apply the injection epoxy as described in step 2. The epoxy level will drop as it penetrates the sand, but should cure and provide a seal to the bottom of the crack. Reapply the epoxy until the crack is filled. In some cases, application of sand is impractical or not permitted and epoxy repair may not provide a complete and effective repair. Use of a gel viscosity injection epoxy (ETI-GV) may permit a surface repair to the crack with partial penetration.

Carbide Drill Bits



Simpson Strong-Tie offers a complete line of premium-quality drill bits, core bits and chisels to handle any drilling demolition and concrete preparation need. Our carbide products are manufactured to demanding tolerances and are designed to maximize production on the jobsite.

Our carbide-tipped drill bits are premium-quality, professional-grade tools manufactured in Germany to the highest industry standards. They are designed to meet precise ANSI tolerance requirements and incorporate proprietary features that enhance durability, drilling speed and usability. Regular and quad-head bit and solid-tipped tip configurations are available. Shank styles include SDS-PLUS, SDS-Max, Spline, and Straight.



Carbide Drill Bits for Concrete and Masonry

Carbide Drill Bit Selection Information

Our carbide-tipped drill bits are premium-quality, professional-grade tools manufactured in Germany to the highest industry standards for Simpson Strong-Tie.

They are designed to meet precise ANSI tolerance requirements and incorporate proprietary features that enhance durability and drilling speed, while improving ease of use. Regular and quad-head bit tip and solid-tipped configurations are available. Shank styles include SDS-PLUS, SDS-MAX, spline and straight.

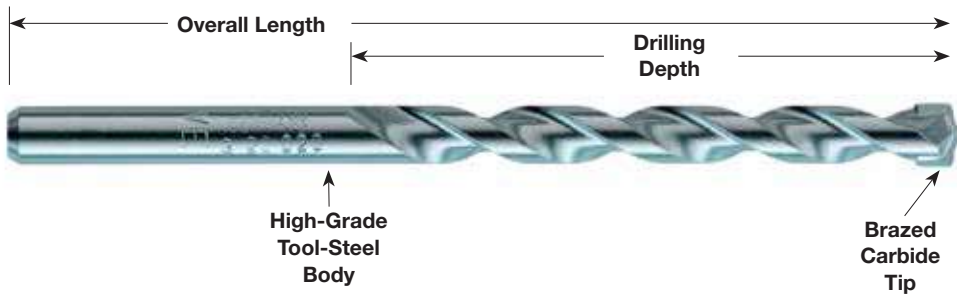

Features and Benefits

- Uniformly brazed carbide inserts result in longer bit life
- Most bits contain a centering tip that facilitates easy spot drilling
- Chromium-nickel-molybdenum steel alloy body ensures hammering quality and extended service life
- Heat-treatment procedures and shot-peened finish increase surface hardness and drilling speed, reduce drill bit wear and improve resistance to bending forces
- Drill bits conform to ANSI Standard B212.15

Additional Features for SDS-MAX, Spline and Select SDS-PLUS Bits:

- Chisel-shaped drill bit head penetrates the material and directs concrete dust into the multi-flute spiral
- Patented, high-volume, multi-flute spiral quickly channels concrete dust from the hole to improve drilling speed
- 4 x 90° head geometry crushes through rebar and prevents sticking in reinforced concrete



Solid-tip carbide drill bit

Quad-Head Feature

(Available in SDS-PLUS, SDS-MAX and spline shank)

All the features of single cutter bits and the quad-head dual-cutter are designed to improve durability and drilling speed. The high-volume, double-helix design of the quad-head bit comes with the patented, high-performance, reinforced core flute to maximize energy transfer.

Simpson Strong-Tie® drill bits come in various shank styles to fit virtually any drill or rotohammer.



SDS-MAX SDS-PLUS Spline Straight 'A' Taper

Carbide Drill Bits for Concrete and Masonry

Drill Bit Tool Selection Guide

SDS-PLUS

Fits all current and older SDS-PLUS rotohammers from AEG, Black & Decker, Bosch, DeWalt, Hitachi, Hilti, Kango, Makita, Metabo, Milwaukee, Porter Cable, Ramset, Red Head, Ryobi, Skil

SDS-MAX

Fits all current and older SDS-MAX rotohammers from Black & Decker, Bosch, DeWalt, Hitachi, Hilti, Kango, Makita, Metabo, Milwaukee

Spline

Fits all current and older Spline rotohammers from AEG, Black & Decker, Bosch, DeWalt, Hitachi, Kango, Makita, Metabo, Milwaukee, Ramset, Red Head, Ryobi

The following are registered trademarks of the respective holders:

AEG® – AEG Power Tool Corp.

Bosch® – Robert Bosch Power Tool Corp.

SDS-PLUS and SDS-MAX are registered trademarks of Robert Bosch Power Tool Corp.

B&D® – Black and Decker US, Inc.

Hilti® – Hilti of America, Inc.

Hitachi® – Hitachi Power Tools USA, Ltd.

Kango® – Kango Wolf Power Tools, Inc.

Makita® – Makita USA, Inc.

Metabo® – Metabo Corp.

Milwaukee® – Milwaukee Electric Tool Corp.

Porter Cable® – Porter Cable Corporation

Ramset® – Illinois Tool Works

Red Head® – Illinois Tool Works

Ryobi® – Ryobi America Corporation



SDS-PLUS Drill Bits

SDS-PLUS Shank Bits

Dia. (in.)	Drilling Depth (in.)	Overall Length (in.)	Model No.
5/32	2	4 1/4	MDPL01504
	4	6 1/4	MDPL01506
3/16	2	4 1/4	MDPL01804
	4	6 1/4	MDPL01806
	6	8 1/4	MDPL01808
	8	10	MDPL01810
	10	12	MDPL01812
	12	14	MDPL01814
7/32	4	6 1/4	MDPL02106
	6	8 1/4	MDPL02108
	11	8 3/4	MDPL02111
	14	16	MDPL02116
1/4	18	20	MDPL02120
	2	4 1/4	MDPL02504
	4	6 1/4	MDPL02506
	6	8 1/4	MDPL02508
	9	11	MDPL02511
	12	14	MDPL02514
5/16	14	16	MDPL02516
	4	6 1/4	MDPL03106
	10	12	MDPL03112
3/8	4	6 1/4	MDPL03706
	8	10 1/4	MDPL03710
	10	12 1/4	MDPL03712
	16	18	MDPL03718
7/16	22	24	MDPL03724
	4	6 1/4	MDPL04306
	10	12 1/4	MDPL04312
1/2	4	6 1/4	MDPL05006
	8	10 1/4	MDPL05010
	10	12 1/4	MDPL05012
	16	18	MDPL05018
9/16	22	24	MDPL05024
	4	6 1/4	MDPL05606
	10	12 1/4	MDPL05612
5/8	16	18	MDPL05618
	6	8	MDPL06208
	10	12	MDPL06212
	16	18	MDPL06218
11/16	22	24	MDPL06224
	6	8	MDPL06808
	6	8	MDPL07508
3/4	8	10	MDPL07510
	10	12	MDPL07512
	16	18	MDPL07518
	22	24	MDPL07524
13/32	6	8	MDPL08108
27/32	6	8	MDPL08408
7/8	6	8	MDPL08708
	10	12 1/4	MDPL08712
	16	18	MDPL08718
1	8	10	MDPL10010
	16	18	MDPL10018

SDS-PLUS Shank Bit

SDS-PLUS bits use an asymmetrical-parabolic flute for efficient energy transmission and dust removal.



SDS-PLUS Solid-Tip Carbide Drill Bits

Diameter (in.)	Total Length (in.)	Drilling Depth (in.)	Model No.
3/16	4 1/4	2	MDPL01804S
3/16	6 1/4	4	MDPL01806S
3/16	8 1/4	6	MDPL01808S
3/16	12	10	MDPL01812S
1/4	6 1/4	4	MDPL02506S
1/4	8 1/4	6	MDPL02508S
1/4	12	10	MDPL02512S
5/16	6 1/4	4	MDPL03106S
5/16	12	10	MDPL03112S
3/8	6 1/4	4	MDPL03706S
3/8	12 1/4	10	MDPL03712S
1/2	6 1/4	4	MDPL05006S
1/2	12 1/4	10	MDPL05012S
9/16	6	4	MDPL05606S
9/16	12	10	MDPL05612S

SDS-PLUS Quad Head Drill Bits

Dia. (in.)	Drilling Depth (in.)	Overall Length (in.)	Model No.
5/8	6	8	MDPL06208Q
	10	12	MDPL06212Q
	16	18	MDPL06218Q
3/4	6	8	MDPL07508Q
	10	12	MDPL07512Q
	16	18	MDPL07518Q
7/8	6	8	MDPL08708Q
	10	12	MDPL08712Q
	16	18	MDPL08718Q
1	8	10	MDPL10010Q
	16	18	MDPL10018Q
1 1/8	8	10	MDPL11210Q
	16	18	MDPL11218Q
1 1/4	16	18	MDPL12518Q



Solid-tip carbide drill bit

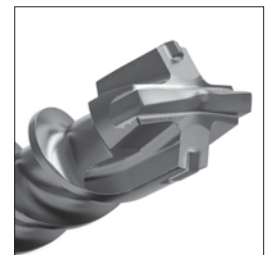

Quad Head

SDS-PLUS Drill Bits

SDS-PLUS Shank Bits — Retail Packs

Dia. (in.)	Drilling Depth (in.)	Overall Length (in.)	Quantity (per pack)	Model No.
5/32	4	6 1/4	25	MDPL01506-R25
3/16	2	4 1/4	25	MDPL01804-R25
	4	6 1/4	25	MDPL01806-R25
	6	8 1/4	25	MDPL01808-R25
	8	10	25	MDPL01810-R25
	10	12	25	MDPL01812-R25
7/32	12	14	25	MDPL01814-R25
	4	6 1/4	25	MDPL02106-R25
	6	8 1/4	25	MDPL02108-R25
1/4	8 3/4	11	25	MDPL02111-R25
	2	4 1/4	25	MDPL02504-R25
	4	6 1/4	25	MDPL02506-R25
	6	8 1/4	25	MDPL02508-R25
5/16	8 3/4	11	25	MDPL02511-R25
	4	6 1/4	25	MDPL03106-R25
3/8	4	6 1/4	25	MDPL03706-R25
	8	10 1/4	25	MDPL03710-R25
	10	12 1/4	25	MDPL03712-R25
1/2	4	6 1/4	25	MDPL05006-R25
	8	10 1/4	25	MDPL05010-R25
	10	12 1/4	25	MDPL05012-R25
5/8	6	8	20	MDPL06208-R20



**SDS-PLUS
Retail Packs**



Stop Bit

Fixed Depth Drill Bits

Model No	Drill Bit Diameter (in.)	Drill Depth (in.)	Drop-In Anchor (in.)
Standard Drop-In Anchors			
MDPL037DIA	3/8	1 1/16	1/4
MDPL050DIA	1/2	1 11/16	3/8
MDPL062DIA	5/8	2 1/16	1/2
Short Drop-In Anchors			
MDPL050DIAS	1/2	1 11/16	3/8
MDPL062DIAS	5/8	2 1/16	1/2

Titen® Screw Drill Bit/Driver Product Data

Dia. (in.)	Drilling Depth (in.)	Overall Length (in.)	For Screw Dia. (in.)	Model No.
5/32	2 3/8	5	3/16	MDPL01505H
	3 1/8	6	3/16	MDPL01506H
	4 1/8	7	3/16	MDPL01507H
3/16	2 3/8	5	1/4	MDPL01805H
	3 1/8	6	1/4	MDPL01806H
	4 1/8	7	1/4	MDPL01807H

Product is sold individually.



Special hex adaptor (included with the Titen® Screw installation kit) allows the Titen installation tool to slide over the bit and lock in, ready to drive Titen concrete and masonry screws. Rotohammer must be in rotation-only mode before driving screws.

Titen Screw Drill Bit/Driver — Bulk Packs

Dia. (in.)	Drilling Depth (in.)	Overall Length (in.)	For Screw Dia. (in.)	Model No.
5/32	2 3/8	5	3/16	MDPL01505H-R25
	4 1/8	7	3/16	MDPL01507H-R25
3/16	2 3/8	5	1/4	MDPL01805H-R25
	4 1/8	7	1/4	MDPL01807H-R25

Titen® Drill Bit/Driver — Bulk Packs of 25

Size (in.)	Drilling Depth (in.)	Overall Length (in.)	For Screw Dia. (in.)	Model No.
5/32 x 5	2 1/4	5	3/16	MDBP15500HB
5/32 x 7	4 1/4	7		MDBP15700HB
3/16 x 5	2 1/4	5	1/4	MDBP18500HB
3/16 x 7	4 1/4	7		MDBP18700HB

SDS-PLUS and SDS-MAX Drill Bits

SDS-MAX and SDS-MAX Quad Head Shank Bits

Dia. (in.)	Drilling Depth (in.)	Overall Length (in.)	Model No.
3/8	7 1/2	13	MDMX03713
1/2	7 1/2	13	MDMX05013
	15 1/2	21	MDMX05021
9/16	7 1/2	13	MDMX05613
	15 1/2	21	MDMX05621
5/8	7 1/2	13	MDMX06213Q
	15 1/2	21	MDMX06221Q
	30 1/2	36	MDMX06236Q
11/16	15 1/2	21	MDMX06821Q
3/4	8	13	MDMX07513Q
	17	21	MDMX07521Q
	31	36	MDMX07536Q
13/16	17	21	MDMX08121Q
7/8	8	13	MDMX08713Q
	17	21	MDMX08721Q
	31	36	MDMX08737Q
1	8	13	MDMX10013Q
	17	21	MDMX10021Q
	31	36	MDMX10036Q
1 1/16	18	23	MDMX10623Q
1 1/8	12	17	MDMX11217Q
	17	21	MDMX11221Q
	31	36	MDMX11236Q
1 3/16	18	23	MDMX11823Q
1 1/4	10	15	MDMX12515Q
	18	23	MDMX12523Q
	31	36	MDMX12536Q
1 3/8	12	17	MDMX13717Q
	18	23	MDMX13723Q
1 1/2	18	23	MDMX15023Q
1 3/4	18	23	MDMX17523Q
2	18	23	MDMX20023Q

Model numbers ending with "Q" denote Quad Head.



Quad Head

Model numbers ending with "Q" denote Quad Head bits.



**SDS-MAX
Shank Bit**

Spline/Straight Shank Drill Bits

Spline Shank Bits

Dia. (in.)	Drilling Depth (in.)	Overall Length (in.)	Model No.
3/8	5	10	MDSP03710
	8	13	MDSP03713
	11	16	MDSP03716
7/16	8	13	MDSP04313
1/2	5	10	MDSP05010
	8	13	MDSP05013
	11	16	MDSP05016
	17	22	MDSP05022
	24	29	MDSP05029
	31	36	MDSP05036
9/16	8	13	MDSP05613
	11	16	MDSP05616
	18	23	MDSP05623
5/8	5	10	MDSP06210
	8	13	MDSP06213
	11	16	MDSP06216
	17	22	MDSP06222
	24	29	MDSP06229
	31	36	MDSP06236
11/16	8	13	MDSP06813
	11	16	MDSP06816
3/4	5	10	MDSP07510
	8	13	MDSP07513
	11	16	MDSP07516
	17	22	MDSP07522
	24	29	MDSP07529
	31	36	MDSP07536
7/8	11	16	MDSP08716
	17	22	MDSP08722
	31	36	MDSP08736
1	11	16	MDSP10016
	17	22	MDSP10022
	31	36	MDSP10036
1 1/8	11	16	MDSP11216
	17	22	MDSP11222
1 1/4	11	16	MDSP12516
	17	22	MDSP12522
1 3/8	11	16	MDSP13716
	17	22	MDSP13722
1 1/2	11	16	MDSP15016
	17	22	MDSP15022
1 3/4	17	22	MDSP17522
2	17	22	MDSP20022



Spline Shank Bit

Spline shank bits continued on the next page.

Spline/Straight Shank Drill Bits

Spline Shank Quad Head Bits

Dia. (in.)	Drilling Depth (in.)	Overall Length (in.)	Model No.
5/8	5	10	MDSP06210Q
	11	16	MDSP06216Q
	17	22	MDSP06222Q
	24	29	MDSP06229Q
	31	36	MDSP06236Q
1 1/16	11	16	MDSP06816Q
3/4	5	10	MDSP07510Q
	11	16	MDSP07516Q
	17	22	MDSP07522Q
	24	29	MDSP07529Q
	31	36	MDSP07536Q
7/8	11	16	MDSP08716Q
	17	22	MDSP08722Q
1	11	16	MDSP10016Q
	17	22	MDSP10022Q
	31	36	MDSP10036Q
1 1/8	11	16	MDSP11216Q
	17	22	MDSP11222Q
1 1/4	11	16	MDSP12516Q
	17	22	MDSP12522Q
	31	36	MDSP12536Q
1 3/8	11	16	MDSP13716Q
	17	22	MDSP13722Q
1 1/2	17	22	MDSP15022Q
1 3/4	18	23	MDSP17523Q
2	18	23	MDSP20023Q



Spline Shank Bit



Quad Head



'A' Taper Bit

'A' Taper Shank Bits

Dia. (in.)	Drilling Depth (in.)	Overall Length (in.)	Model No.
1/2	7	9	MDA05007
5/8	7	9	MDA06207
3/4	16	18	MDA07516

Carbide Drill Bits

Spline/Straight Shank Drill Bits

Straight Shank Bits

Dia. (in.)	Drilling Depth (in.)	Overall Length (in.)	Model No.
1/8	1 3/8	3	MDB01203
3/16	1 9/16	3 1/2	MDB01803
	4	6	MDB01806
1/4	2 1/8	4	MDB02504
	4	6	MDB02506
	10	12	MDB02512
5/16	2 3/4	4 3/4	MDB03104
	4	6	MDB03106
3/8	4	6	MDB03706
	10	12	MDB03712
7/16	4	6	MDB04306
1/2	4	6	MDB05006
	10	12	MDB05012
	22	24	MDB05024
5/8	3 1/2	6	MDB06206
	10	12	MDB06212
	22	24	MDB06224
3/4	4	6	MDB07506
	10	12	MDB07512
7/8	4	6	MDB08706
	10	12	MDB08712
1	4	6	MDB10006
	10	12	MDB10012

Bits have recessed shank to fit Titen® screws and other masonry screw installation tools. They also work in three-jaw-style chucks.



Straight Shank Bit

Straight Shank Bits – Retail Packs

Dia. (in.)	Drilling Depth (in.)	Overall Length (in.)	Quantity (per pack)	Model No.
1/8	1 3/8	3	25	MDB01203-R25
3/16	1 9/16	3 1/2	25	MDB01803-R25
	4	6	25	MDB01806-R25
1/4	2 1/8	4	25	MDB02504-R25
	4	6	25	MDB02506-R25
5/16	2 3/4	4 3/4	25	MDB03104-R25
	4	6	25	MDB03106-R25
3/8	4	6	25	MDB03706-R25
1/2	4	6	25	MDB05006-R25
5/8	4	6	20	MDB06206-R20



Rebar Cutters/Adaptors

Rebar Cutters**

When hole placement conflicts with rebar or wire mesh, these bits enable the rebar to be removed so the hole can be drilled to the proper depth. Rebar cutters are separate from shanks. Shanks work with all sizes of rebar cutters. Overall length is approximately 15".

** After drilling through the reinforcement or plate, remove debris from the hole and resume drilling with carbide tipped drill bit.

Dia. (in.)	Drilling Depth (in.)	Model No.
1/2	12	MCR05012
5/8	12	MCR06212
3/4	12	MCR07512
7/8	12	MCR08712
1	12	MCR10012



Rebar Cutter Detail



Rebar Cutter

Plate Cutters**

Similar to rebar cutters, these bits are designed for cutting through steel base plates when it is necessary to enlarge the fixture hole. These bits can also be used as rebar cutters. Plate cutters are separate from shanks. Shanks work with all sizes of plate cutters.

** After drilling through the reinforcement or plate, remove debris from the hole and resume drilling with carbide-tipped drill bit.

Dia. (in.)	Drilling Depth (in.)	Model No.
1/2	12	MCP05012
5/8	12	MCP06212
3/4	12	MCP07512
7/8	12	MCP08712
1	12	MCP10012



Plate Cutter Detail



Plate Cutter

Shanks for Rebar and Plate Cutters

Shank Style	Model No.	Description
Straight	MC	For use in drills with jawed chucks. Use in rotation mode only.
SDS-PLUS	MCSDP	For use in SDS-PLUS style drills. Use in rotation mode only.
SDS-MAX	MCSDM	For use in SDS-MAX style drills. Shank design allows rotation only.
Spline	MCS	For use in spline-style drills. Shank design allows rotation only.



SDS-PLUS Shank



Spline Shank

Rebar Cutters/Adaptors

Drill Bit Shank Adaptors

Description (shank style to bit type)	Model No.
SDS-MAX to SDS-PLUS Adaptor	ADMX2PL
Spline to SDS-PLUS Adaptor	ADSP2PL
SDS-top to SDS-PLUS Adaptor	ADST2PL



SDS-MAX to SDS-PLUS Adaptor



Spline to SDS-PLUS Adaptor



**SDS-Top
(T-ET style) to SDS-PLUS Adaptor**

Demolition Chisels and Bits

Simpson Strong-Tie® chisels are made of toughened steel with special surface treatment that improves performance. The superior tempering process creates a hardened surface that is more wear resistant and allows the working point to be re-sharpened, which extends the life of the tool.

Simpson Strong-Tie® demolition chisels and bits come in various shank styles to fit virtually any demolition tool.



SDS-MAX



SDS-PLUS



Spline

(Design disables rotohammer rotation.)



3/4" Hex

Scrapers

Removing Tiles, Flooring and Other Materials

Shank Type	Head Width (in.)	Overall Length (in.)	Model No.
SDS-PLUS	3/4	10	CHPLF07510
	1 1/2	10	CHPLSC15010
SDS-MAX	2	12	CHMXSCP20012
Spline	2	12	CHSPSCP20012



Scraper

Flat Chisels

General Concrete and Masonry Demolition

Shank Type	Head Width (in.)	Overall Length (in.)	Model No.
SDS-MAX	1	12	CHMXF10012
	1	18	CHMXF10018
Spline	1	12	CHSPF10012
	1	18	CHSPF10018
3/4" Hex	1	12	CHHF10012
	1	18	CHHF10018



Flat Chisel

Demolition Chisels and Bits

Bull Point Chisels

General Concrete and Masonry Demolition

Shank Type	Overall Length (in.)	Model No.
SDS-PLUS	10	CHPLBP10
SDS-MAX	12	CHMXBP12
	18	CHMXBP18
Spline	12	CHSPBP12
	18	CHSPBP18
¾" Hex	12	CHHBP12
	18	CHHBP18



Bull Point Chisel

Asphalt Cutters

Asphalt, Hardpan and Compacted Soil Cutting

Shank Type	Head Width (in.)	Overall Length (in.)	Model No.
SDS-MAX	3½	16	CHMXAC35016
¾" Hex	3½	16	CHHAC35016



Asphalt Cutter

Clay Spades

Clay and Other Rock-Free Soil Cutting

Shank Type	Head Width (in.)	Overall Length (in.)	Model No.
Spline	5%	16	CHSPCS53716
Clay Spade	5%	16	CHHCS53716



Clay Spade

Demolition Bits

Scalers

Removing Large Quantities of Material

Shank Type	Head Width (in.)	Overall Length (in.)	Model No.
SDS-MAX	1½	12	CHMXSC15012
	2	12	CHMXSC20012
	3	12	CHMXSC30012
Spline	1½	12	CHSPSC15012
	2	12	CHSPSC20012
	3	12	CHSPSC30012
¾" Hex	2	12	CHHSC20012
	3	12	CHHSC30012



Scaler

Ground Rod Drivers

Driving in Ground Rods

Shank Type	Head Width (in.)	Overall Length (in.)	Model No.
SDS-MAX	7/8	10¼	CHMXRD08710
Spline	7/8	10¼	CHSPRD08710



Ground Rod Driver

Bushing Tools One Piece

Concrete and Asphalt Surface Roughening

Shank Type	Head Width (in.)	Overall Length (in.)	Model No.
SDS-MAX	1¾	9½	CHMXBT17509
Spline	1¾	9¼	CHSPBT17509
Bushing Tool	1¾	9¼	CHHBT17509



Bushing Tool Head

Core Bits

Core Bits

Simpson Strong-Tie® Core Bits are made to the same exacting standards as our standard carbide-tipped drill bits. They utilize a centering bit to facilitate accurate drilling in combination hammer/drill mode.

One-Piece Core Bits with Centering Bit – SDS-MAX Shank

Dia. (in.)	Drilling Depth (in.)	Overall Length (in.)	Model No.
1½	6¼	11⅝	CBMX15011
		22	CBMX15022
2	6¼	11⅝	CBMX20011
		22	CBMX20022
2⅝	6¼	11⅝	CBMX26211
		22	CBMX26222
3⅝	6¼	11⅝	CBMX31211
		22	CBMX31222
3½	6¼	22	CBMX35022
4	6¼	11⅝	CBMX40011
		22	CBMX40022
5	6¼	11⅝	CBMX50011
		22	CBMX50022
6	6¼	22	CBMX60022

NOTE: With 1-piece bits, once coring is begun, the centering bit must be removed using ejector pin. Core bit bodies are 2¼" deep.



One-piece core bit transfers energy efficiently

One-Piece Core Bits with Centering Bit – Spline Shank

Dia. (in.)	Drilling Depth (in.)	Overall Length (in.)	Model No.
1½	6¼	11⅝	CBSP15012
		22	CBSP15022
2	6¼	11⅝	CBSP20011
		22	CBSP20022
2⅝	6¼	11⅝	CBSP26211
		22	CBSP26222
3⅝	6¼	11⅝	CBSP31211
		22	CBSP31222
3½	6¼	11⅝	CBSP35011
		22	CBSP35022
4	6¼	11⅝	CBSP40011
		22	CBSP40022
5	6¼	11⅝	CBSP50011
		22	CBSP50022

Core Bit Replacement Parts

Core Bit Center Pilot Bit

Dia. (in.)	Overall Length (in.)	Model No.
7/16	4¾	CTRBTF04304

Ejector Key

Dia. (in.)	Model No.
⅜	CDBEJKEY

Appendix – Supplemental Topics

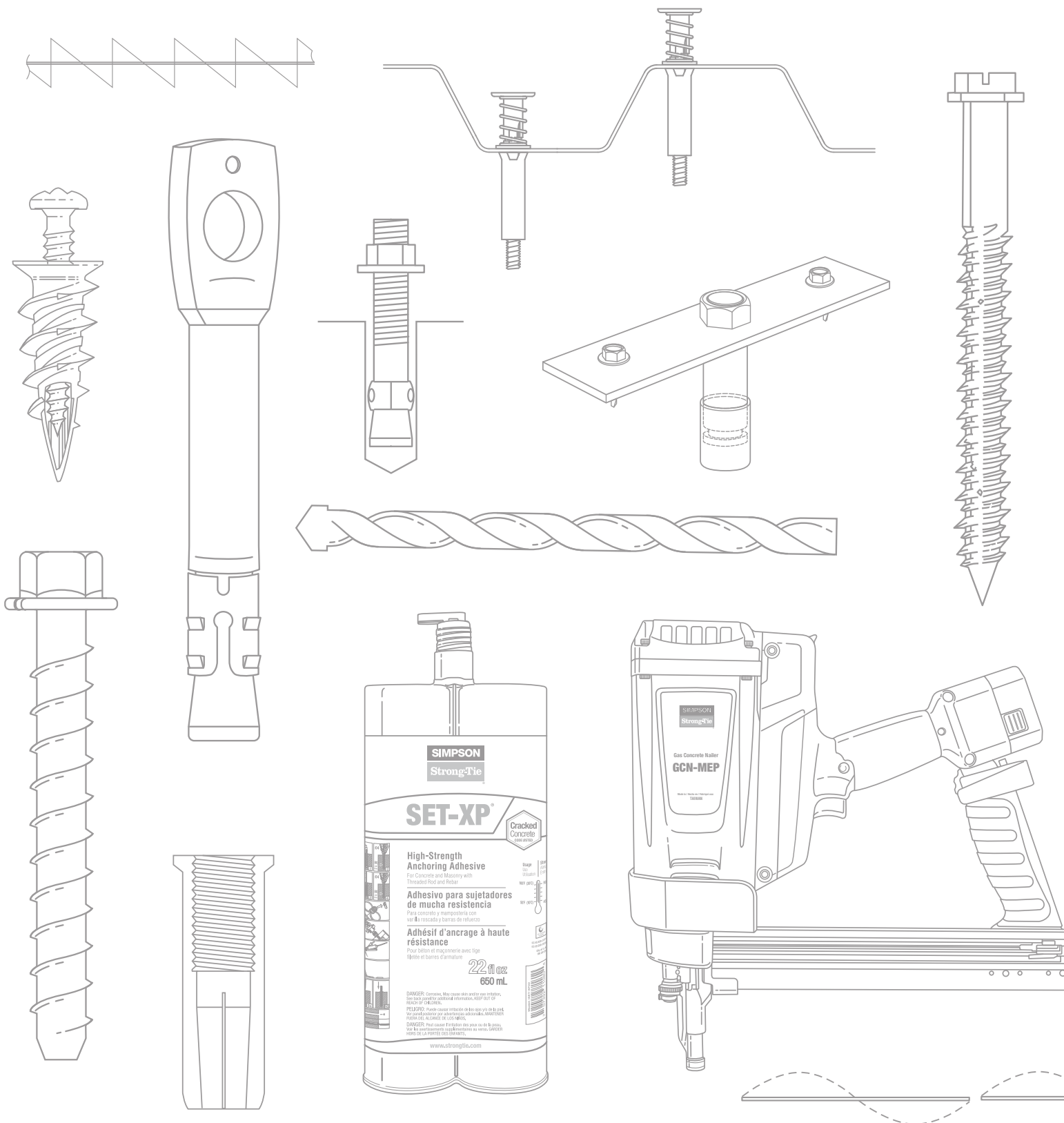

To keep you as informed as possible, the following topics are included in this Appendix:

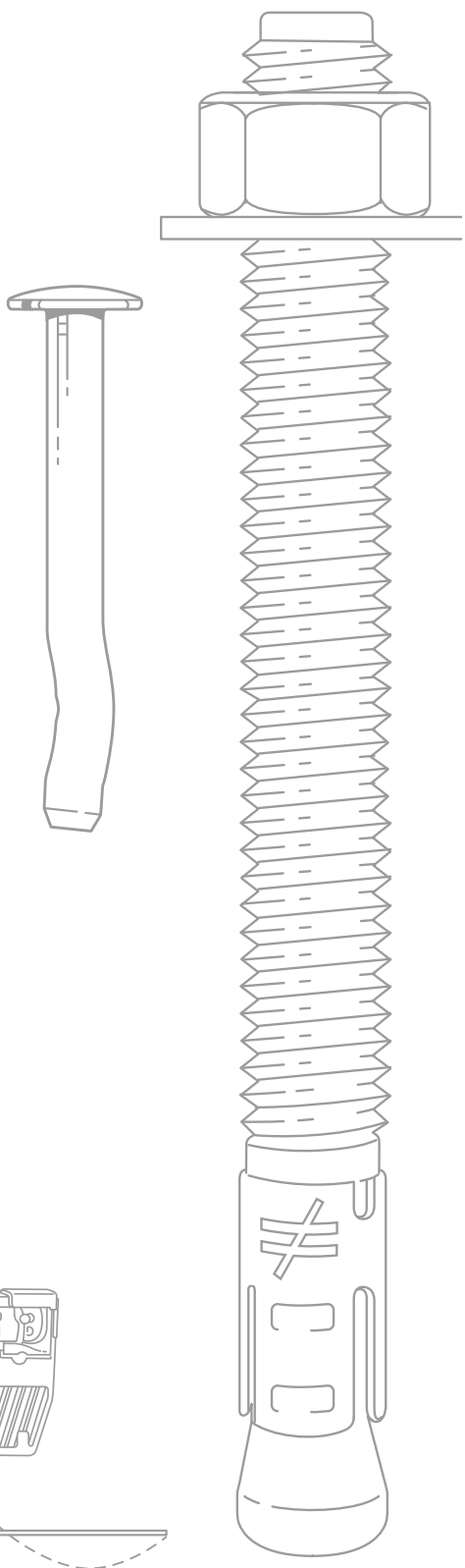

Supplemental Topics for Anchors	Page
I. Base Materials	316
II. Anchor Failure Modes	316
III. Corrosion Resistance	316
IV. Mechanical Anchors	318
V. Adhesive Anchors	318
Allowable Stress Design (ASD) Method	322
Strength Design (SD) Method	322
AC308 Modifications to ACI 318	323
Example Calculations	324



Supplemental Topics for Anchors

I. Base Materials

“Base material” is a generic industry term that refers to the element or substrate to be anchored to. Base materials include concrete, brick, concrete block (CMU) and structural tile, to name a few. The most common type of base material where adhesive and mechanical anchors are used is concrete.

Concrete – Concrete can be cast-in-place or precast concrete. Concrete has excellent compressive strength, but relatively low tensile strength. Cast-in-place (or sometimes called “poured in place”) concrete is placed in forms erected on the building site. Cast-in-place concrete can be either normal-weight or lightweight concrete. Lightweight concrete is often specified when it is desirable to reduce the weight of the building structure.

Lightweight concrete differs from normal-weight concrete by the weight of aggregate used in the mixture. Normal-weight concrete has a unit weight of approximately 150 pounds per cubic foot compared to approximately 115 pounds per cubic foot for lightweight concrete.

The type of aggregate used in concrete can affect the tension capacity of an adhesive anchor. Presently, the relationship between aggregate properties and anchor performance is not well understood. Test results should not be assumed to be representative of expected performance in all types of concrete aggregate.

Prefabricated concrete is also referred to as “precast concrete”. Precast concrete can be made at a prefabricating plant or site-cast in forms constructed on the job. Precast concrete members may be solid or may contain hollow cores. Many precast components have thinner cross sections than cast in place concrete. Precast concrete may use either normal or lightweight concrete. Reinforced concrete contains steel bars, cable, wire mesh or random glass fibers. The addition of reinforcing material enables concrete to resist tensile stresses which lead to cracking.

The compressive strength of concrete can range from 2,000 psi to over 20,000 psi, depending on the mixture and how it is cured. Most concrete mixes are designed to obtain the desired properties within 28 days after being cast.

Concrete Masonry Units (CMU) – Block is typically formed with large hollow cores. Block with a minimum 75% solid cross section is called solid block even though it contains hollow cores. In many parts of the country building codes require steel reinforcing bars to be placed in the hollow cores, and the cores to be filled solid with grout.

In some areas of the eastern United States, past practice was to mix concrete with coal cinders to make cinder blocks. Although cinder blocks are no longer made, there are many existing buildings where they can be found. Cinder blocks require special attention as they soften with age.

Brick – Clay brick is formed solid or with hollow cores. The use of either type will vary in different parts of the United States. Brick can be difficult to drill and anchor into. Most brick is hard and brittle. Old, red clay brick is often very soft and is easily over-drilled. Either of these situations can cause problems in drilling and anchoring. The most common use of brick today is for building facades (curtain wall or brick veneer) and not for structural applications. Brick facade is attached to the structure by the use of brick ties spaced at intervals throughout the wall. In older buildings, multiple widths, or “wythes” of solid brick were used to form the structural walls. Three and four wythe walls were common wall thicknesses.

Clay Tile – Clay tile block is formed with hollow cores and narrow cavity wall cross sections. Clay tile is very brittle, making drilling difficult without breaking the block. Caution must be used in attempting to drill and fasten into clay tile.

II. Anchor Failure Modes

Four different tension failure modes and three different shear failure modes are generally observed for post-installed anchors under tension loading.

Failure Modes

Tension	Shear
Steel Fracture Breakout Pullout (Mech. Anch.) Bond Failure (Adhesive Anch.)	Steel Fracture Breakout Pryout

Breakout Failure – Breakout failure occurs when the base material ruptures, often producing a cone-shaped failure surface when anchors are located away from edges, or producing a spall when anchors are located near edges. Breakout failure can occur for both mechanical and adhesive anchors and is generally observed at shallower embedment depths, and for installations at less than critical spacings or edge distances.

Pullout Failure – Pullout failure occurs when a mechanical anchor pulls out of the drilled hole, leaving the base material otherwise largely intact.

Bond Failure – Bond failure occurs when an adhesive anchor pulls out of the drilled hole due to an adhesion failure at the adhesive-to-base-material interface, or when there is a cohesive failure within the adhesive itself. When bond failure occurs, a shallow cone-shaped breakout failure surface will often form near the base material surface. This breakout surface is not the primary failure mechanism.

Pryout Failure – Pryout failure occurs for shallowly embedded anchors when a base material failure surface is pried out “behind” the anchor, opposite the direction of the applied shear force.

Steel Fracture – Steel fracture occurs when anchor spacings, edge distances and embedment depths are great enough to prevent the base-material-related failure modes listed above and the steel strength of the mechanical anchor or adhesive anchor insert is the limiting strength.

III. Corrosion Resistance

Many environments and materials can cause corrosion, including ocean salt air, fire-retardants, fumes, fertilizers, preservative-treated wood, de-icing salts, dissimilar metals and more. Metal fixtures, fasteners and anchors can corrode and lose load-carrying capacity when installed in corrosive environments or when installed in contact with corrosive materials.

The many variables present in a building environment make it impossible to accurately predict if, or when, corrosion will begin or reach a critical level. This relative uncertainty makes it crucial that specifiers and users are knowledgeable about the potential risks and select a product suitable for the intended use. It is also prudent that regular maintenance and periodic inspections are performed, especially for outdoor applications.

It is common to see some corrosion in outdoor applications. Even stainless steel can corrode. The presence of some corrosion does not mean that load capacity has been affected or that failure is imminent. If significant corrosion is apparent or suspected, then the fixtures, fasteners and connectors should be inspected by a qualified engineer or qualified inspector. Replacement of affected components may be appropriate.

Chemical Attack - Chemical attack occurs when the anchor material is not resistant to a substance with which it is in contact. Chemical-resistance information regarding anchoring adhesives is found on page 320.

Supplemental Topics for Anchors

Some wood-preservative chemicals and fire-retardant chemicals and retentions pose increased corrosion potential and are more corrosive to steel anchors and fasteners than others. Additional information on this subject is available at www.strongtie.com.

We have attempted to provide basic knowledge on the subject of corrosion here, but it is important to fully educate yourself by reviewing our technical bulletins on the topic (www.strongtie.com/info) and also by reviewing information, literature and evaluation reports published by others.

Galvanic Corrosion - Galvanic corrosion occurs when two electrochemically dissimilar metals contact each other in the presence of an electrolyte (such as water) that acts as a conductive path for metal ions to move from the more anodic to the more cathodic metal. In the galvanic couple, the more anodic metal will corrode preferentially. The Galvanic Series of Metals table provides a qualitative guide to the potential for two metals to interact galvanically. Metals in the same group (see table) have similar electrochemical potentials. The farther the metals are apart on the table, the greater the difference in electrochemical potential, and the more rapidly galvanic corrosion will occur. Corrosion also increases with increasing conductivity of the electrolyte.

Good detailing practice, including the following, can help reduce the possibility of galvanic corrosion of anchors:

- Use of anchors and metals with similar electrochemical potentials
- Separating dissimilar metals with insulating materials
- Ensuring that the anchor is the cathode, when dissimilar materials are present.
- Preventing exposure to and pooling of electrolytes

Galvanic Series of Metals

Corroded End (Anode)
Magnesium Magnesium alloys Zinc
Aluminum 1100 Cadmium Aluminum 2024-T4 Iron and Steel
Lead Tin Nickel (active) Inconel Ni-Cr alloy (active) Hastelloy alloy C (active)
Brasses Copper Cu-Ni alloys Monel
Nickel (passive)
304 stainless steel (passive) 316 stainless steel (passive) Hastelloy alloy C (passive)
Silver Titanium Graphite Gold Platinum
Protected End (Cathode)

Hydrogen-Assisted Stress-Corrosion Cracking

Some hardened fasteners may experience premature failure if exposed to moisture as a result of hydrogen-assisted stress-corrosion cracking. These fasteners are recommended specifically for use in dry, interior locations.

Guidelines for Selecting Corrosion-Resistant Anchors and Fasteners

Evaluate the Application

Consider the importance of the connection.

Evaluate the Exposure

Consider these moisture and treatment chemical exposure conditions:

- **Dry Service:** Generally INTERIOR applications and includes wall and ceiling cavities, raised floor applications in enclosed buildings that have been designed to prevent condensation and exposure to other sources of moisture. Prolonged exposure during construction should also be considered, as this may constitute a Wet Service or Elevated Service Condition.
- **Wet Service:** Generally EXTERIOR construction in conditions other than Elevated Service. These include Exterior Protected and Exposed and General Use Ground Contact as described by the AWPA UC4A.
- **Elevated Service:** Includes fumes, fertilizers, soil, some preservative-treated wood (AWPA UC4B and UC4C), industrial zones, acid rain and other corrosive elements.
- **Uncertain:** Unknown exposure, materials or treatment chemicals.
- **Ocean/Water Front:** Marine environments that include airborne chlorides and some splash. Environments with de-icing salts are included.
- **Treatment Chemicals:** See AWPA Use Category Designations. The preservative-treated wood supplier should provide all of the pertinent information about the wood being used. The information should include Use Category Designation, wood species group, wood treatment chemical and chemical retention. See appropriate evaluation reports for corrosion effects of treatment chemicals and fastener corrosion resistance recommendations.

Use the Simpson Strong-Tie® Corrosion Classification Table

If the treatment chemical information is incomplete, Simpson Strong-Tie recommends the use of a 300-series stainless-steel product. Also if the treatment chemical is not shown in the Corrosion Classification Table, then Simpson Strong-Tie has not evaluated it and cannot make any recommendations other than the use of coatings and materials in the Severe category. Manufacturers may independently provide test results of other product information; Simpson Strong-Tie expresses no opinion regarding such information.

Minimum Corrosion Resistance Recommendations

Corrosion Resistance Classification	Material or Coating
Low	Zinc plated
Medium	Mechanically galvanized (ASTM B695-Class 55) ¹
	Hot-dip galvanized (ASTM A153-Class C)
	Type 410 stainless steel with protective top coat
High	Type 302, 303 or 304 stainless steel
Severe	Type 316 stainless steel
	Hot-dip galvanized

1. Mechanically galvanized Titen HD® anchors are recommended only for temporary outdoor service.

Supplemental Topics for Anchors

Corrosion Resistance Classifications

Environment	Material To Be Fastened						
	Untreated Wood or Other Material	Preservative-Treated Wood					FRT Wood
		SBX-DOT Zinc Borate	Chemical Retention ≤ AWPA, UC4A	Chemical Retention > AWPA, UC4A	ACZA	Other or Uncertain	
Dry Service	Low	Low	Low	High	High	High	Med
Wet Service	Med	N/A	Med	High	High	High	High
Elevated Service	High	N/A	Severe	Severe	High	Severe	N/A
Uncertain	High	High	High	Severe	High	Severe	High
Ocean/Waterfront	Severe	N/A	Severe	Severe	Severe	Severe	N/A

1. These are general guidelines that may not consider all application criteria. Refer to product-specific information for additional guidance.
2. Type 316/305/304 stainless-steel products are recommended where preservative-treated wood used in ground contact has chemical retention level greater than those for AWPA UC4A; CA-C, 0.15 pcf; CA-B, 0.21 pcf; micronized CA-C, 0.14 pcf; micronized CA-B, 0.15 pcf; ACQ-Type D (or C), 0.40 pcf.
3. Testing by Simpson Strong-Tie following ICC-ES AC257 showed that mechanical galvanization (ASTM B695, Class 55), Quik Guard coating, and Double Barrier coating will provide corrosion resistance equivalent to hot-dip galvanization (ASTM A153, Class D) in contact with chemically treated wood in dry service and wet service exposures (AWPA UC1 – UC4A, ICC-ES AC257 Exposure Conditions 1 and 3) and will perform adequately subject to regular maintenance and periodic inspection.
4. Mechanical galvanizations C3 and N2000 should not be used in conditions that would be more corrosive than AWPA UC3A (exterior, above ground, rapid water run off).
5. If uncertain about Use Category, treatment chemical, or environment, use Types 316/305/304 stainless steel, silicon bronze or copper fasteners.
6. Some treated wood may have excess surface chemicals making it potentially more corrosive than lower retentions. If this condition is suspected, use Types 316/305/304 stainless steel, silicon bronze or copper fasteners.
7. Types 316/305/304 stainless steel, silicon bronze or copper fasteners are the best recommendation for ocean salt-air and other chloride-containing environments. Hot-dip galvanized fasteners with at least ASTM A153, Class C protection can also be an alternate for some applications in environments with ocean air and/or elevated wood moisture content.

IV. Mechanical Anchors

Pre-Load Relaxation

Expansion anchors that have been set to the required installation torque in concrete will experience a reduction in pre-tension (due to torque) within several hours. This is known as pre-load relaxation. The high compression stresses placed on the concrete cause it to deform which results in a relaxation of the pre-tension force in the anchor. Tension in this context refers to the internal stresses induced in the anchor as a result of applied torque and does not refer to anchor capacity. Historical data shows it is normal for the initial tension values to decrease by as much as 40–60% within the first few hours after installation. Retorquing the anchor to the initial installation torque is not recommended or necessary.

Oversized Holes

The performance data for adhesive anchors are based upon anchor tests in which holes were drilled with carbide-tipped drill bits of the same diameter listed in the product's load table. Additional static tension tests were conducted to qualify anchors installed with SET, SET-XP®, ET-HP® and AT adhesives for installation in holes with diameters larger than those listed in the load tables. The tables indicate the acceptable range of drilled hole sizes and the corresponding tension-load reduction factor (if any). The same conclusions also apply to the published shear load values. Drilled holes outside of the accepted range shown in the charts are not recommended.

SET Adhesive – Acceptable Hole Diameter

Insert Diameter (in.)	Acceptable Hole Diameter Range (in.)	Acceptable Load Reduction Factor
3/8	1/2 – 3/4	1.0
1/2	5/8 – 1 1/16	1.0
5/8	3/4 – 1 1/8	1.0
3/4	7/8 – 1 5/16	1.0
7/8	1 – 1 1/2	1.0
1	1 1/8 – 1 11/16	1.0
1 1/8	1 1/4 – 1 7/8	1.0
1 1/4	1 3/8 – 2 1/16	1.0
1 3/8	1 1/2 – 2 1/4	1.0

SET-XP and ET-HP Adhesives – Acceptable Hole Diameter

Insert Diameter (in.)	Acceptable Hole Diameter Range (in.)	Acceptable Load Reduction Factor
1/2	5/8 – 3/4	1.0
5/8	3/4 – 1 1/16	1.0
3/4	7/8 – 1 1/8	1.0
7/8	1 – 1 5/16	1.0
1	1 1/8 – 1 1/2	1.0
1 1/4	1 3/8 – 1 7/8	1.0

V. Adhesive Anchors

Installation into Green Concrete

The strength design data for adhesive anchors in this catalog are based on installations into concrete that is at least 21 days old. Anchors may be installed in concrete less than 21 days old, provided a reduction factor is applied to bond strength:

Products	Concrete Age When Installed	Concrete Age When Loaded	Bond Strength Factor
AT AT-XP ET-HP SET SET-XP	14 days	21 days	1.0
		7 days	0.9
	7 days	21 days	1.0
		7 days	0.7

Supplemental Topics for Anchors

AT Adhesive – Acceptable Hole Diameter

Insert Diameter (in.)	Acceptable Hole Diameter Range (in.)	Acceptable Load Reduction Factor
3/8	7/16 – 1/2	1.0
1/2	9/16 – 5/8	1.0
5/8	1 1/16 – 3/4	1.0
3/4	1 3/16 – 7/8	1.0
7/8	1	1.0
1	1 1/16 – 1 1/8	.75 for 1 1/8 only

Core-Drilled Holes

The performance data for adhesive anchors are based upon anchor tests in which holes were drilled with carbide-tipped drill bits. Additional static tension tests were conducted to qualify anchors installed with SET and AT anchoring adhesives for installation in holes drilled with diamond-core bits. In these tests, the diameter of the diamond-core bit matched the diameter of the carbide-tipped drill bit recommended in the product's load table. The test results showed that no reduction of the published allowable tension load for SET and AT anchoring adhesives is necessary for this condition. The same conclusions also apply to the published allowable shear loads.

Installation in Damp, Wet and Submerged Environments

SET-XP, ET-HP and AT-XP: The performance data for adhesive anchors using SET-XP, ET-HP and AT-XP adhesives are based upon tests according to ICC-ES AC308. This criteria requires adhesive anchors that are to be installed in outdoor environments to be tested in water-saturated concrete holes that have been cleaned with less than the amount of hole cleaning recommended by the manufacturer. A product's sensitivity to this installation condition is considered in determining the product's "Anchor Category" (strength reduction factor). SET-XP, ET-HP and AT-XP may be installed in dry or water-saturated concrete.

Based on Reliability Testing per ICC-ES AC308

- Dry Concrete – Cured concrete whose moisture content is in equilibrium with surrounding non-precipitate atmospheric conditions.
- Water-Saturated Concrete – Cured concrete that is covered with water and water saturated.
- Submerged Concrete – Cured concrete that is covered with water and water saturated.
- Water-Filled Hole – Drilled hole in water-saturated concrete that is clean yet contains standing water at the time of installation.

SET, EDOT and AT: The performance data for adhesive anchors using SET, EDOT and AT adhesives are based upon tests in which anchors are installed in dry holes. Additional static tension tests were conducted for some products in damp holes, water-filled holes and submerged holes. The test results show that no reduction of the published allowable tension load is necessary for SET, EDOT and AT adhesives in damp holes, or for SET and AT adhesives in water-filled holes. For SET and AT adhesives in submerged holes, the test results show that a reduction factor of 0.60 is applicable. The same conclusions also apply to the published allowable shear load values.

Based on Reliability Testing per ICC-ES AC58

- Dry Concrete – Cured concrete whose moisture content is in equilibrium with surrounding non-precipitate atmospheric conditions.
- Damp Hole – A damp hole, as defined in ASTM E1512 and

referenced in ICC-ES AC58, is a drilled hole that has been properly drilled, cleaned and then is filled with standing water for seven days. After seven days, the standing water is blown out of the hole with compressed air and the adhesive anchor is installed.

- Water-Filled Hole – A water-filled hole is defined similarly to a damp hole; however, the standing water is not blown out of the hole. Instead, the adhesive is injected directly into the water-filled hole (from the bottom of the hole up) and the insert is installed.
- Submerged Hole – A submerged hole is similar to a water-filled hole with one major exception – in addition to standing water within the hole, water also completely covers the surface of the base material. Note that drilling debris and sludge should be removed from the drilled hole prior to installation. ICC-ES AC58 does not address this condition.

Elevated In-Service Temperature

The performance of all adhesive anchors is affected by elevated base material temperature. The in-service temperature sensitivity table provided for each adhesive provides the information necessary to apply the appropriate load adjustment factor to either the allowable tension based on bond strength or allowable shear based on concrete edge distance for a given base material temperature. While there is no commonly used method to determine the exact load-adjustment factor, there are a few guidelines to keep in mind when designing an anchor that will be subject to elevated base-material temperature. In any case, the final decision must be made by a qualified design professional using sound engineering judgment:

- When designing an anchor connection to resist wind and/or seismic forces only, the effect of fire (elevated temperature) may be disregarded.
- The base-material temperature represents the average internal temperature and, hence, the temperature along the entire bonded length of the anchor.
- The effects of elevated temperature may be temporary. If the in-service temperature of the base material is elevated such that a load-adjustment factor is applicable but, over time, the temperature is reduced to a temperature below which a load-adjustment factor is applicable, the full allowable load based on bond strength is still applicable. This is applicable provided that the degradation temperature of the anchoring adhesive (350°F for SET-XP®, SET, ET-HP®, AT-XP® and AT adhesives) has not been reached.

Creep Under Long-Term Loads

Creep is the slow, continuous deformation of a material under constant stress. Creep occurs in many construction materials, including concrete and steel when the stress is great enough. The creep characteristics of adhesives are product-dependent. Adhesive anchors that are not creep-resistant can pull out slowly over time when sustained tensile loads are applied.

Because of the creep phenomenon, it is important for Designers to consider the nature of the applied tension loads and to determine whether the tension loads will be continuously applied to the anchor over the long term. If this is the case, a product that is suitable for resisting sustained loads over the long term must be selected.

All Simpson Strong-Tie® anchoring adhesives (SET-XP, SET, ET-HP, EDOT, AT-XP and AT) have been qualified for resisting long-term loads through ICC-ES AC58 or ICC-ES AC308 "creep tests" in which an anchor is loaded and monitored for movement over time. According to AC58 and AC308, anchors that pass the creep test are determined to be suitable for resisting long-term tensile loads.

Supplemental Topics for Anchors

Chemical Resistance of Adhesive Anchors

Samples of Simpson Strong-Tie® anchoring adhesives were immersed in the chemicals shown below until they exhibited minimal weight change (indicating saturation) or for a maximum of three months. The samples were then tested according to ASTM D 543 *Standard Practices for Evaluating the Resistance of Plastics to Chemical Changes*, Procedures I & II, and either ASTM D 790 *Standard Test Method for Flexural Properties of Unreinforced and Reinforced Plastics and Electrical Insulating Materials* or ASTM D 695 *Standard Test Method for Compressive Properties of Rigid Plastics*. In cases where mild chemicals were evaluated, the exposure was accelerated per ASTM D 3045 *Standard Practice for Heat Aging of Plastics Without Load*.

Samples showing no visible damage and demonstrating statistically equivalent strength and elastic modulus as compared to control samples were classified as “Resistant” (R). These adhesives are considered suitable for continuous exposure to the identified chemical when used as a part of an adhesive anchor assembly.

Samples exhibiting slight damage, such as swelling or crazing, or not demonstrating both statistically equivalent strength and elastic modulus as compared to control samples were classified as “Non-Resistant” (NR). These adhesives are considered suitable for periodic exposure to the identified chemical if the chemical will be diluted and washed away from the adhesive anchor assembly after exposure, or if only emergency contact with the chemical is expected and subsequent replacement of the anchor would be undertaken. Some manufacturers refer to this as “limited resistance” or “partial resistance” in their literature.

Samples that were completely destroyed by the chemical, or that demonstrated a significant loss in strength after exposure were classified as “Failed” (F). These adhesives are considered unsuitable for exposure to the identified chemical.

Note: In most actual service conditions, the majority of the anchoring adhesive is not exposed to the chemical and thus some period of time is required for the chemical to saturate the entire adhesive. An adhesive anchor would be expected to maintain bond strength and creep resistance until a significant portion of the adhesive is saturated.

Chemical	Concentration	AT-XP	SET-XP	ET-HP	AT	SET
Acetic Acid	Glacial	NR	F	F	F	F
	5%	R	F	F	R	F
Acetone	100%	F	F	F	—	—
Aluminum Ammonium Sulfate (Ammonium Alum)	10%	R	R	R	R	R
Aluminum Chloride	10%	R	R	R	—	—
Aluminum Potassium Sulfate (Potassium Alum)	10%	R	R	R	R	R
Aluminum Sulfate (Alum)	15%	R	R	R	R	R
	28%	NR	R	NR	R	R
	10%	R	R	R	R	R
Ammonium Hydroxide (Ammonia)	pH=10	R	R	R	—	—
	15%	R	R	R	R	R
Ammonium Nitrate	15%	R	R	R	R	R
Ammonium Sulfate	15%	R	R	R	R	R
Automotive Antifreeze	50%	R	R	R	—	—
Aviation Fuel (JP5)	100%	R	R	R	—	—
Brake Fluid (DOT3)	100%	R	NR	F	—	—
Calcium Hydroxide	10%	R	R	R	—	—
Calcium Hypochlorite (Chlorinated Lime)	15%	R	R	R	R	R
Calcium Oxide (Lime)	5%	R	R	R	R	R
	10%	NR	F	F	—	—
Carbolic Acid	5%	NR	F	F	—	—
	100%	R	R	R	—	—
Chromic Acid	40%	R	NR	NR	—	—
Citric Acid	10%	R	R	R	—	—
Copper Sulfate	10%	R	R	R	—	—
Detergent (ASTM D543)	100%	R	R	R	—	—
Diesel Oil	100%	R	R	NR	—	—
Ethanol, Aqueous	95%	NR	F	F	—	—
	50%	NR	NR	NR	—	—
Ethanol, Denatured	100%	R	F	F	—	—
Ethylene Glycol	100%	R	R	R	—	—
Fluorosilicic Acid	25%	R	R	R	R	R
Formic Acid	Concentrated	F	F	F	—	—
	10%	R	F	F	—	—
Gasoline	100%	R	R	R	—	—
Hydrochloric Acid	Concentrated	NR	F	F	R	F
	10%	R	NR	F	R	NR
	pH=3	R	R	R	—	—
Hydrogen Peroxide	30%	R	F	F	R	F
	3%	R	R	R	R	NR
Iron (II) Chloride (Ferrous Chloride)	15%	R	R	R	R	R
Iron (III) Chloride (Ferric Chloride)	15%	R	R	R	R	NR
Iron (III) Sulfate (Ferric Sulfate)	10%	R	R	F	—	—
Isopropanol	100%	R	F	F	—	—
Lactic Acid	85%	R	F	F	—	—
	10%	R	F	F	—	—
Machine Oil	100%	R	R	R	—	—
Methanol	100%	NR	F	F	—	—
Methyl Ethyl Ketone	100%	NR	F	F	—	—

Supplemental Topics for Anchors

Chemical	Concentration	AT-XP	SET-XP	ET-HP	AT	SET
Methyl Isobutyl Ketone	100%	NR	NR	NR	—	—
Mineral Oil	100%	R	R	R	—	—
Mineral Spirits	100%	R	R	R	—	—
Mixture of Amines ¹	100%	R	F	F	—	—
Mixture of Aromatics ²	100%	NR	NR	R	—	—
Motor Oil (5W30)	100%	R	R	R	—	—
N,N-Diethylaniline	100%	R	R	R	—	—
Nitric Acid	Concentrated	F	F	F	F	F
	40%	NR	F	F	F	F
	10%	R	R	F	R	NR
	pH=3	R	R	R	—	—
Phosphoric Acid	85%	R	F	F	F	F
	40%	R	F	F	R	NR
	10%	R	F	F	R	NR
	pH=3	R	R	R	—	—
Potassium Hydroxide	40%	NR	R	NR	—	—
	10%	NR	R	R	—	—
	pH=13.2	R	R	R	—	—
Potassium Permanganate	10%	R	R	R	R	R
Propylene Glycol	100%	R	R	NR	—	—
Seawater (ASTM D1141)	100%	R	R	R	—	—
Soap (ASTM D543)	100%	R	R	R	—	—
Sodium Bicarbonate	10%	R	R	R	R	R
Sodium Bisulfite	15%	R	R	R	R	NR
Sodium Carbonate	15%	R	R	R	R	R
Sodium Chloride	15%	R	R	R	R	R
Sodium Fluoride	10%	R	R	R	R	R
Sodium Hexafluorosilicate (Sodium Silicon Fluoride)	5%	R	R	R	R	R
Sodium Hydrosulfide	10%	R	R	R	—	—
Sodium Hydroxide	60%	R	R	R	—	—
	40%	R	R	R	—	—
	10%	R	R	R	—	—
	pH=10	R	R	R	—	—
Sodium Hypochlorite (Bleach)	25%	R	R	R	R	R
	10%	R	R	R	R	R
Sodium Nitrate	15%	R	R	R	R	R
Sodium Phosphate (Trisodium Phosphate)	10%	R	R	R	R	R
Sodium Silicate	50%	R	R	R	R	R
Sulfuric Acid	Concentrated	F	F	F	F	F
	30%	R	NR	F	R	NR
	3%	R	NR	F	R	NR
	pH=3	R	R	R	—	—
Toluene	100%	NR	F	NR	—	—
Triethanol Amine	100%	R	NR	R	—	—
Turpentine	100%	R	R	R	—	—
Water	100%	R	R	R	R	R
Xylene	100%	NR	NR	R	—	—

“R” – Resistant, “NR” – Non-Resistant, “F” – Failed, “—” – Not tested

1. triethanol amine, n-butylamine, N,N-dimethylamine

2. toluene, methyl naphthalene, xylene

Allowable Stress Design (ASD) Method

In allowable stress design (ASD), the Designer must size the anchorage such that the service load does not exceed the allowable load for any anchor:

$$\begin{aligned} T_{service} &\leq T_{allowable} \\ V_{service} &\leq V_{allowable} \end{aligned}$$

The Designer must read the allowable load from the applicable table and adjust the allowable load for all applicable design parameters for the anchor, such as spacing, edge distance, in-service temperature or allowable-stress increase for short-term loads. Load-adjustment factors for anchors are applied cumulatively. For adhesive anchors, the designer must also ensure that the service load does not exceed the allowable load of the steel insert.

For anchors subjected to simultaneous tension and shear loading, the following equation must be satisfied, where the value of n is product-specific. Use a value of $n=1$ unless otherwise specified in the applicable products' load table.

$$\left(\frac{T_{service}}{T_{allowable}}\right)^n + \left(\frac{V_{service}}{V_{allowable}}\right)^n \leq 1.0$$

Linear interpolation of allowable loads between embedment depths and/or compressive strengths shown in the load tables is permitted. Linear interpolation of load-adjustment factors in the edge distance and spacing tables is also permitted.

The allowable loads in this catalog are derived from full-scale testing, calculations, and/or experience. In general, the allowable load is determined by taking the average ultimate load from full scale tests and dividing by a safety factor (Ω).

$$T_{allowable} = \frac{\bar{T}_{ultimate}}{\Omega}; \quad V_{allowable} = \frac{\bar{V}_{ultimate}}{\Omega}$$

For some anchors, the average ultimate load and/or allowable load is also controlled by anchor displacement limits.

The allowable loads for steel inserts used with adhesive anchors is determined as follows:

For threaded rod: $T_{allowable} = 0.33F_u A_g$; $V_{allowable} = 0.17F_u A_g$

For Grade 60 rebar: $T_{allowable} = (24,000 \text{ psi})A_g$; $V_{allowable} = 0.17(90,000 \text{ psi})A_g$

Where:

A_g = Gross cross-sectional area of the insert

Threaded Insert Steel Type	F _u (psi)
F1554, Grade 36	58,000
A193, Grade B7	125,000
304/316 Stainless (Diam. ≤ 5/8")	100,000
304/316 Stainless (Diam. ≥ 3/4")	85,000

Where:

F_u = Ultimate tensile strength of steel insert

Strength Design (SD) Method (Under ACI 318 APPENDIX D, ICC-ES AC193, and ICC-ES AC308)

In strength design (SD), the Designer must size the anchorage such that the required strength (i.e. factored load) does not exceed the lowest design strength of the anchor or anchor group considering all possible failure modes.

$$N_{ua} \leq \phi N_n$$

$$V_{ua} \leq \phi V_n$$

Calculations are performed in accordance with the applicable design standards: ICC-ES AC193 and ACI 318 Appendix D for mechanical anchors and ICC-ES AC308 for adhesive anchors. The additional design provisions of AC308 are shown elsewhere in this catalog.

The nominal strengths and design data in this catalog are derived from testing and calculations in accordance with ACI 355.2. ACI 355.4, ICC-ES AC193 and ICC-ES AC308. In general, nominal strengths are 5% fractile strengths calculated using the average ultimate load, and standard deviation of full-scale test results. A 5% fractile strength is the nominal strength for which there is a 90% confidence that there is a 95% probability of the actual strength exceeding the nominal strength.

For anchors that are designed using ACI 318 Appendix D, AC193, or AC308, it is possible to convert design strengths (i.e. ϕN_n or ϕV_n) to allowable loads using the following approach from AC193:

$$T_{allowable, ASD} = \frac{\phi N_n}{\alpha} \quad \text{and} \quad V_{allowable, ASD} = \frac{\phi V_n}{\alpha}$$

Where:

$T_{allowable, ASD}$ = Allowable tension load

$V_{allowable, ASD}$ = Allowable shear load

ϕN_n = Lowest design strength of an anchor or anchor group in tension as determined per ACI 318 Appendix D, AC193, AC308 and the IBC.

ϕV_n = Lowest design strength of an anchor or anchor group in shear as determined per ACI 318 Appendix D, AC193, AC308 and the IBC.

α = Conversion factor calculated as a weighted average of the load factors for the controlling load combination. In addition, α shall include all applicable factors to account for non-ductile failure modes and required over-strength.

Interaction shall be calculated as follows:

For tension loads, $T \leq 0.2T_{allowable}$ the full allowable load in shear shall be permitted.

For shear loads, $V \leq 0.2V_{allowable}$ the full allowable load in tension shall be permitted.

$$\text{For all other cases: } \frac{T}{T_{allowable}} + \frac{V}{V_{allowable}} \leq 1.2$$

AC308 Modifications to ACI 318

4.2.1 Replace Section D.5.5.5, and add Sections D.5.3.7 and D.8.6.1 to ACI 318 as follows:

4.2.2 D.5.5.5 – The modification factor for adhesive anchors designed for uncracked concrete in accordance with D.5.5.2 without supplementary reinforcement to control splitting, $\psi_{cp,Na}$, shall be computed as:

$$\text{If } c_{a,min} \geq c_{ac} \text{ then } \psi_{cp,Na} = 1.0 \quad (\text{D-26})$$

$$\text{If } c_{a,min} < c_{ac} \text{ then } \psi_{cp,Na} = \frac{c_{a,min}}{c_{ac}} \quad (\text{D-27})$$

where

c_{ac} shall be determined in accordance with Eq. (D-27a) for anchor diameters up to 1¼ inches and for characteristic bond strengths in uncracked concrete less than or equal to 3,000 psi, and Eq. (D-27b) for anchor diameters larger than 1¼ inches or for characteristic bond strengths in uncracked concrete greater than 3,000 psi.

$$c_{ac} = h_{ef} \cdot \left(\frac{\tau_{k,uncr}}{1160} \right)^{0.4} \cdot \left[3.1 - 0.7 \frac{h}{h_{ef}} \right] \quad (\text{D-27a})$$

$$c_{ac} = h_{ef} \cdot \left(\frac{\tau_{k,uncr}}{664} \right)^{0.4} \cdot \left[3.1 - 0.7 \frac{h}{h_{ef}} \right] \quad (\text{D-27b})$$

where

$\left[\frac{h}{h_{ef}} \right]$ need not be taken as larger than 2.4; and

$\tau_{k,uncr}$ = characteristic bond strength stated in the Evaluation Service Report whereby $\tau_{k,uncr}$ need not be taken as larger than:

$$\tau_{k,uncr} = \frac{k_{uncr} \sqrt{h_{ef} f'_c}}{\pi \cdot d}$$

In no case shall $\psi_{cp,Na}$ determined from Eq. (D-27) be taken as less than c_{Na} / c_{ac} . For all other cases, $\psi_{cp,Na}$ shall be taken as 1.0.

NOTE: Bond strength determination: Bond strength values are a function of the special-inspection level provided and installation conditions. Bond strength values must be modified with the factor K_{sat} for cases where the holes are drilled in water-saturated concrete as follows:

Special Inspection Level	Permissible Installation Condition	Bond Strength	Associated Strength Reduction Factor
Continuous	Dry Concrete	τ_k	$\Phi_{dry,ci}$
Continuous	Water-saturated	$\tau_k \times K_{sat,ci}$	$\Phi_{sat,ci}$
Periodic	Dry Concrete	τ_k	$\Phi_{dry,pi}$
Periodic	Water-saturated	$\tau_k \times K_{sat,pi}$	$\Phi_{sat,pi}$

Where applicable, the modified bond strengths must be used in lieu of $\tau_{k,cr}$ or $\tau_{k,uncr}$ in ACI 318. The resulting nominal bond strength must be multiplied by the strength-reduction factor for the special-inspection level listed above.

Example Calculations Adhesive Anchors (Traditional ASD)

Example calculation for a grouping of adhesive anchors using ASD:

Design a connection comprised of four ¾" diameter all-thread rods installed in $f'_c = 2,000$ psi concrete using SET adhesive as shown. The anchor grouping is subject to an applied tension load of 3,000 lb. and an applied shear load of 1,000 lb. acting simultaneously.

ADDITIONAL DATA:

- All-thread rod material: ASTM A1554 Grade 36.
- All-thread rod embedment depth: 6¾"
- All-thread rod spacing: S1=S3=8", S2=11.3" (use 11")
($S_{critical} = 27" > S_{actual}$, therefore reduced efficiency.)
- All-thread rod edge distance: C1=C2=3"
($C_{critical} = 10\frac{1}{8}" > C_{actual}$, therefore reduced efficiency.)

SOLUTION:

Unadjusted allowable tension loads:

- Based on adhesive bond strength = $T_{bond} = 10,525$ lbs.
- Based on steel strength = $T_{steel} = 8,460$ lbs.

Unadjusted allowable shear loads:

- Based on concrete strength = $V_{conc} = 6,310$ lbs.
- Based on steel strength = $V_{steel} = 4,360$ lbs.

Calculate reduced efficiency factors for all-thread rod installed at an edge distance of 3" using tables on pages 116–117:

- Tension: C1=C2=3", $f_c = 0.56$ from f_c - Tension Table
- Shear: C1=C2=3", $f_c = 0.29$ from f_c - Shear Table

Calculate reduced efficiency factors for all-thread rod installed at a spacing of 8" using tables on pages 118–119:

- Tension: S1=S3=8", $f_s = 0.91$ from f_s - Tension Table
S2=11", $f_s = 0.925$ from f_s - Tension Table
- Shear: S1=S3=8", $f_s = 0.95$ from f_s - Shear Table
S2=11", $f_s = 1.00$ from f_s - Shear Table

Reduce allowable tension value based on bond strength. The reduction factors are cumulative due to the influence of two reduced edge distance conditions and three reduced spacing conditions:

$$\begin{aligned} (T_{bond})_{net} &= (f_c)(f_s)(T_{bond}) \\ &= (0.56 \times 0.56)(0.91 \times 0.91 \times 0.925)(10,525 \text{ lbs.}) \\ &= 2,528 \text{ lbs.} \end{aligned}$$

Allowable tension value is the lesser of:

- Tension based on net bond strength = **2,528 lbs.** (governs) or
- Tension based on steel strength = 8,460 lbs.

For a group of 4 anchors the combined allowable tension value is:

$$\begin{aligned} &= (4 \text{ anchors})(2,528 \text{ lbs./anchor}) = \mathbf{10,112 \text{ lbs.} > 3,000 \text{ lbs.}} \\ &\text{(design tension) O.K.} \end{aligned}$$

(Note: If high in-service temperature is expected, the allowable based on bond/concrete should be multiplied by a strength reduction factor found in the adhesive's temperature sensitivity table.)

Reduce allowable shear value based on concrete strength. The reduction factors are cumulative due to the influence of two reduced edge-distance conditions and three reduced spacing conditions:

$$\begin{aligned} (V_{conc})_{net} &= (f_c)(f_s)(V_{conc}) \\ &= (0.29 \times 0.29)(.95 \times .95 \times 1.00)(6,310 \text{ lbs.}) \\ &= 478 \text{ lbs.} \end{aligned}$$

Allowable shear value is the lesser of:

- Shear based on net concrete strength = **478 lbs.** (governs) or
- Shear based on steel strength = 4,360 lbs.

For a group of 4 anchors the combined allowable shear value is:

$$\begin{aligned} &= (4 \text{ anchors})(478 \text{ lbs./anchor}) = \mathbf{1,912 \text{ lbs.} > 1,000 \text{ lbs.}} \\ &\text{(design shear) O.K.} \end{aligned}$$

(Note: If high in-service temperature is expected, the allowable shear based on bond/concrete should be multiplied by a strength reduction factor found in the adhesive's temperature sensitivity table.)

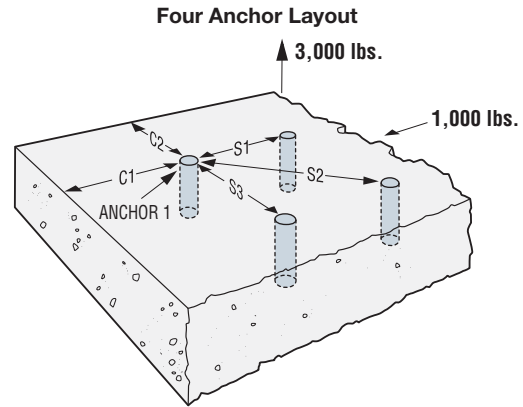

The allowable tension (or shear) value for a group of anchors is equal to the lowest (minimum) tension (or shear) value for a single anchor within the group multiplied by the number of anchors within the group.

CHECK COMBINED TENSION AND SHEAR INTERACTION:

For adhesive anchors, use the straight-line method ($n=1.0$, see Figure 1) when calculating the interaction of both tension and shear upon the anchor per the following equation:

$$(\text{Design shear/allowable shear})^n + (\text{Design tension/allowable tension})^n \leq 1.0, n=1.0$$

Design shear (V) = 1,000 lbs.

Allowable shear (V_{all}) = 1,912 lbs.

Design tension (T) = 3,000 lbs.

Allowable tension (T_{all}) = 10,112 lbs.

$$(1,000/1,912)^{1.0} + (3,000/10,112)^{1.0} = 0.82 \leq 1.0 \text{ O.K.}$$

Figure 1

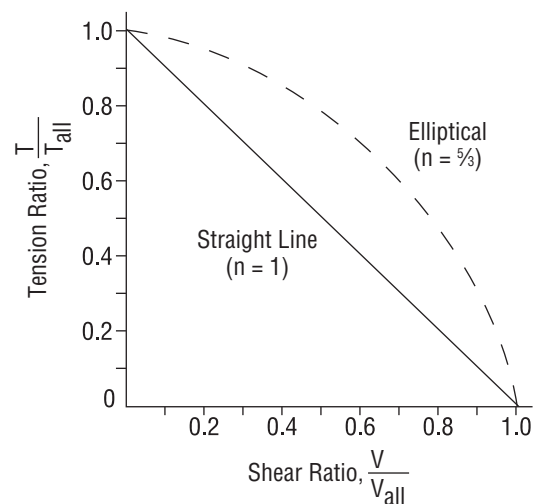

Example Calculations Mechanical Anchors (Traditional ASD)

Example calculation for a group of (2) Titen HD® anchors using ASD:

Design a connection comprised of two (2) ¾" diameter Titen HD® anchors installed in the face of an 8" normal weight grouted CMU wall as shown. The anchor group has an applied tension load of 600 lbs. and an applied shear load of 500 lbs. acting simultaneously.

ADDITIONAL DATA:

- Embedment depth = 5 ½"
- Spacing = $S_{act} = S1 = 8"$
- Critical spacing for ¾" dia. anchor at embedment = $S_{cr} = 12"$
- $S_{act} < S_{cr}$ therefore use spacing reduction factor for S1.
- End distance = $C_{act} = C1 = 4"$
- Edge distance = $C_{act} = C2 = 12"$
- Critical edge distance = $C_{cr} = 12"$
- Critical end distance = $C_{cr} = 12"$
- $C1 < C_{cr}$, therefore use perpendicular-to-edge reduction factor for C1.
- $C2 > C_{cr}$, therefore no edge reduction factor for C2.

SOLUTION:

Tension

Determine uninfluenced allowable tension load in the face of an 8" normal wt. concrete grouted CMU wall:

Uninfluenced allowable tension = 1,600 lbs.

Calculate reduced efficiency factors for Edge Distance:

$$C_{act} = C1 = 4"$$

$$C_{act} = C2 = 12"$$

$$f_{cC1} = 0.66 = \text{Load adjustment factor (pages 198–199)}$$

Calculate reduced efficiency factor for spacing:

$$S_{act} = S1 = 8"$$

$$f_{sS1} = 0.67 = \text{Load adjustment factor (page 200)}$$

Calculate allowable tension load per anchor:

$$\text{Allowable tension} = (\text{uninfluenced allowable tension}) (f_{cC1}) (f_{sS1})$$

$$\text{Allowable tension} = (1,600 \text{ lbs.}) (0.66) (0.67) = 708 \text{ lbs. per anchor}$$

For a group of 2 anchors the combined allowable tension value is:
= (2 anchors)(708 lbs./anchor) = **1,416 lbs. > 600 lbs.**
(design tension) O.K.

Shear

Determine uninfluenced allowable shear load in the face of an 8" normal wt. concrete grouted CMU wall:

Uninfluenced allowable shear = 3,000 lbs.

Calculate reduced efficiency factor for end distance:

$$C_{act} = C1 = 4"$$

$$C_{act} = C2 = 12"$$

$$f_{cC1} = 0.21 = \text{Load adjustment factor (pages 198–199)}$$

Calculate reduced efficiency factor for spacing:

$$S_{act} = S1 = 8"$$

$$f_{sS1} = 0.75 = \text{Load adjustment factor (page 200)}$$

Calculate allowable shear load per anchor:

$$\text{Allowable shear} = (\text{uninfluenced allowable shear}) (f_{cC1}) (f_{sS1})$$

$$\text{Allowable shear} = (3,000 \text{ lbs.}) (0.21) (0.75) = 473 \text{ lbs. per anchor}$$

For a group of 2 anchors the combined allowable shear value is:
= (2 anchors)(473 lbs./anchor) = **945 lbs. > 500 lbs.**
(design shear) O.K.

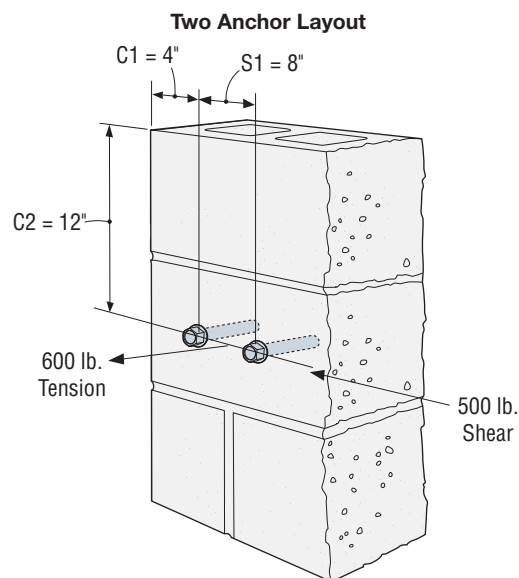

The allowable tension (or shear) value for a group of anchors is equal to the lowest (minimum) tension (or shear) value for a single anchor within the group multiplied by the number of anchors within the group.

CHECK COMBINED TENSION AND SHEAR INTERACTION:

For the Titen HD® in grouted CMU, use the straight-line method ($n = 1$, see Figure 1) when calculating the interaction of both tension and shear upon the anchor per the following equation:

$$(\text{Design shear}/\text{Allowable shear})^n + (\text{Design tension}/\text{Allowable tension})^n \leq 1.0, n = 1$$

$$\text{Design shear (V)} = 500 \text{ lbs.}$$

$$\text{Allowable shear (V}_{all}) = 945 \text{ lbs.}$$

$$\text{Design tension (T)} = 600 \text{ lbs.}$$

$$\text{Allowable tension (T}_{all}) = 1,416 \text{ lbs.}$$

$$(600/1,416)^1 + (500/945)^1 = 0.95 \leq 1.0 \text{ O.K.}$$

Figure 1

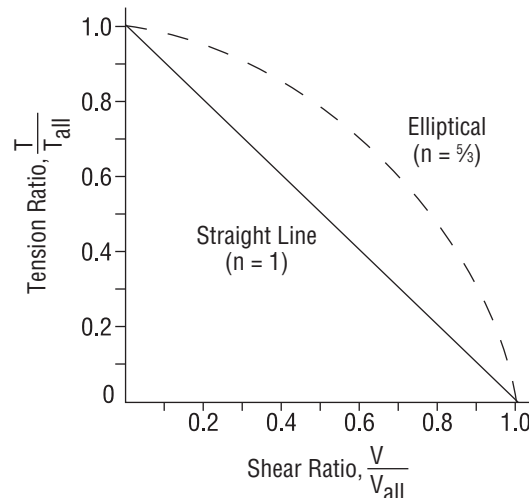

Example Calculations Mechanical Anchors (ACI 318 App. D / ICC-ES AC193)

Example calculation for a single Strong-Bolt™ 2 anchor using SD:

Determine if a single 1/2" diameter carbon-steel Strong-Bolt™ 2 torque-controlled expansion anchor with a minimum 3 7/8" embedment ($h_{ef} = 3 7/8$ inches) installed 4" from the edge of a 12" deep spandrel beam is adequate for a strength level tension load of 1,600 lb. for wind and a reversible strength level shear load of 560 lb. for wind. The anchor will be in the tension zone, away from other anchors in $f'_c = 3,000$ psi normal-weight concrete.

Reference the appropriate tables in this catalog for Strong-Bolt 2 anchor performance values as determined from testing in accordance with ACI 355.2 and ICC-ES AC193.

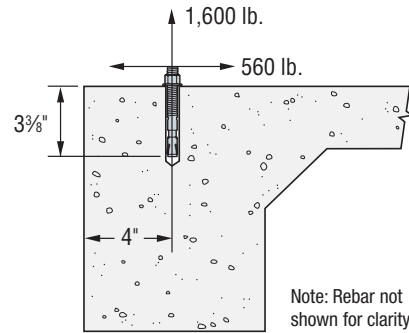

CALCULATIONS AND DISCUSSION

Note: Calculations are performed in accordance with ACI 318-11.

- Determine the factored tension and shear design loads:

$$N_{ua} = 1.0W = 1.0 \times 1,600 = 1,600 \text{ lb.}$$

$$V_{ua} = 1.0W = 1.0 \times 560 = 560 \text{ lb.}$$

- Design considerations:

This is a combined tension and shear interaction problem where values for both ϕN_n and ϕV_n need to be determined. ϕN_n is the lesser of the design tension strength controlled by: steel (ϕN_{sa}), concrete breakout (ϕN_{cb}), or pull-out ($\phi n N_{pn}$). ϕV_n is the lesser of the design shear strength controlled by: steel (ϕV_{sa}), concrete breakout (ϕV_{cb}), or pryout (ϕV_{cp}).

- Steel capacity under tension Loading:

$$\phi N_{sa} \geq N_{ua}$$

$$N_{sa} = 12,100 \text{ lb.}$$

$$\phi = 0.75$$

$$n = 1 \text{ (single anchor)}$$

Calculating for ϕN_{sa} :

$$\phi N_{sa} = 0.75 \times 1 \times 12,100 = 9,075 \text{ lb.} > 1,600 \text{ lb. O.K.}$$

REFERENCE

ACI 318, 9.2.1

D.4.1.1

D.5.1

D.4.1.1

This catalog

This catalog

CALCULATIONS AND DISCUSSION

- Concrete breakout capacity under tension loading:

$$\phi N_{cb} \geq N_{ua}$$

$$N_{cb} = \frac{A_{Nc}}{A_{Nco}} \psi_{ed,N} \psi_{c,N} \psi_{cp,N} N_b$$

where:

$$N_b = k_c \lambda_a \sqrt{f'_c} h_{ef}^{1.5}$$

substituting:

$$\phi N_{cb} = \phi \frac{A_{Nc}}{A_{Nco}} \psi_{ed,N} \psi_{c,N} \psi_{cp,N} k_c \lambda_a \sqrt{f'_c} h_{ef}^{1.5}$$

where:

$$k_c = k_{cr} = 17$$

(Anchor is installed in a tension zone, therefore, cracking is assumed at service loads)

$$\lambda = 1.0 \text{ for normal-weight concrete}$$

$$\psi_{cp,N} = 1.0$$

$$\psi_{ed,N} = 0.7 + 0.3 \frac{c_{a,min}}{1.5h_{ef}} \text{ when } c_{a,min} < 1.5h_{ef}$$

by observation, $c_{a,min} = 4 < 1.5h_{ef}$

$$\psi_{ed,N} = 0.7 + 0.3 \frac{(4)}{1.5(3.375)} = 0.94$$

$\psi_{c,N} = 1.0$ assuming cracking at service loads ($f_t > f_t$)

$$\phi = 0.65 \text{ for Condition B}$$

(no supplementary reinforcement provided)

$$A_{Nco} = 9h_{ef}^2 = 9(3.375)^2 = 102.52 \text{ in.}^2$$

$$A_{Nc} = (c_{a1} + 1.5h_{ef})(2 \times 1.5h_{ef}) = (4 + 1.5(3.375))(2 \times 1.5(3.375)) = 91.76 \text{ in.}^2$$

$$\frac{A_{Nc}}{A_{Nco}} = \frac{91.76}{102.52} = 0.90$$

Calculating for ϕN_{cb} :

$$\phi N_{cb} = 0.65 \times 0.90 \times 0.94 \times 1.0 \times 1.0 \times 17 \times 1.0 \times \sqrt{3,000} \times (3.375)^{1.5} = 3,175 \text{ lb.} > 1,600 \text{ lb. O.K.}$$

REFERENCE

D.5.2

D.4.1.1

Eq. (D-3);

Eq. (D-6)

This catalog

8.6.1

D.5.2.7

Eq. (D-10)

D.5.2.6

This catalog

Eq. (D-5)

Fig. RD.5.2.1(a)

Would you like help with these calculations? Visit www.strongtie.com to download the Simpson Strong-Tie® Anchor Designer™ software.

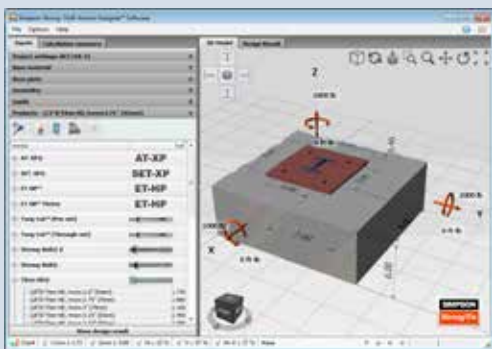

Continued on next page

Example Calculations Mechanical Anchors (ACI 318 App. D / ICC-ES AC193)

CALCULATIONS AND DISCUSSION

5. Pullout capacity under tension loading:

Pullout capacity, $N_{p,cr}$, is established by reference tests in cracked concrete by the reliability test of ACI 355.2. Data from the anchor prequalification testing must be used. Reference Strong-Bolt® 2 anchor "characteristic tension design values" table for the 5 percent fractile value, $N_{p,cr}$.

$$\phi N_{pn} \geq N_{ua}$$

$$N_{p,cr} = 3,735 \times \left(\frac{3,000}{2,500} \right)^{0.5} = 4,091 \text{ lb.}$$

$$\phi = 0.65$$

$$\phi N_{pn} = 0.65 \times 4,091 = 2,659 \text{ lb.} > 1,600 \text{ lb. O.K.}$$

6. Check all failure modes under tension loading:

Summary:

$$\text{Steel capacity} = 9,075 \text{ lb.}$$

$$\text{Concrete breakout capacity} = 3,175 \text{ lb.}$$

$$\text{Pullout capacity} = 2,659 \text{ lb.} \leftarrow \text{Controls}$$

$\therefore \phi N_n = 2,659 \text{ lb. as pullout capacity controls}$

7. Steel capacity under shear loading:

$$\phi V_{sa} \geq V_{ua}$$

$$V_{sa} = 7,235 \text{ lb.}$$

$$\phi = 0.65$$

Calculating for ϕV_{sa} :

$$\phi V_{sa} = 0.65 \times 7,235 = 4,703 \text{ lb.} > 560 \text{ lb. O.K.}$$

8. Concrete breakout capacity under shear loading:

$$\phi V_{cb} \geq V_{ua}$$

$$V_{cb} = \frac{A_{Vc}}{A_{Vco}} \psi_{ed,v} \psi_{c,v} \psi_{h,v} V_b$$

where:

$$V_b = 7 \left(\frac{\ell_e}{d_a} \right)^{0.2} \sqrt{d_a} \lambda_a \sqrt{f'_c} c_{a1}^{1.5}$$

substituting:

$$\phi V_{cb} = \phi \frac{A_{Vc}}{A_{Vco}} \psi_{ed,v} \psi_{c,v} \psi_{h,v} 7 \left(\frac{\ell_e}{d_a} \right)^{0.2} \sqrt{d_a} \lambda_a \sqrt{f'_c} c_{a1}^{1.5}$$

where:

$$\phi = 0.70 \text{ for Condition B}$$

(no supplementary reinforcement provided)

$$A_{Vco} = 4.5c_{a1}^2$$

$$= 4.5(4)^2$$

$$\therefore A_{Vco} = 72 \text{ in.}^2$$

$$A_{Vc} = 2(1.5c_{a1})(1.5c_{a1})$$

$$= 2(1.5(4))(1.5(4))$$

$$\therefore A_{Vc} = 72 \text{ in.}^2$$

$$\frac{A_{Vc}}{A_{Vco}} = \frac{72}{72} = 1$$

$$h_a = 12 \text{ in.}$$

$$\psi_{h,v} = 1.0 \text{ since } h_a > 1.5 c_{a1}$$

$$\psi_{ed,v} = 1.0 \text{ since } c_{a2} > 1.5c_{a1}$$

$$\psi_{c,v} = 1.0 \text{ assuming cracking at service loads } (f_t > f_r)$$

$$d_a = 0.5 \text{ in.}$$

$$\ell_e = 3.375 \text{ in.}$$

$$\lambda_a = 1.0 \text{ for normal-weight concrete}$$

$$c_{a1} = 4 \text{ in.}$$

$$\phi V_{cb} = 0.70 \times 1 \times 1.0 \times 1.0 \times 1.0 \times 7 \times \left(\frac{3.375}{0.5} \right)^{0.2} \times \sqrt{0.5} \times 1.0$$

$$\times \sqrt{3,000} \times (4)^{1.5} = 2,224 \text{ lb.} > 560 \text{ lb. O.K.}$$

REFERENCE

D.5.3

D.4.1.1

This catalog

This catalog

D.4.1.1

D.6.1

D.4.1.1

This catalog

This catalog

D.6.2

D.4.1.1

Eq. (D-30)

Eq. (D-33)

D4.4(c)(i)

Eq. (D-32)

Fig. RD.6.2.1(a)

D.6.2.1

D.6.2.8

Eq. (D-37)

D.6.2.7

D.6.2.2

8.6.1

CALCULATIONS AND DISCUSSION

9. Concrete pryout strength:

$$\phi n V_{cp} \geq V_{ua}$$

$$V_{cp} = k_{cp} N_{cb}$$

where:

$$n = 1$$

$$k_{cp} = 2.0 \text{ and } \phi = 0.70$$

$$k_{cp} N_{cb} = 2.0 \times \frac{3,175}{0.65} = 9,769 \text{ lb.}$$

$$\phi n V_{cp} = 0.70 \times 1 \times 9,769 = 6,838 \text{ lb.} > 560 \text{ lb. O.K.}$$

10. Check all failure modes under shear Loading:

Summary:

$$\text{Steel capacity} = 4,703 \text{ lb.}$$

$$\text{Concrete breakout capacity} = 2,224 \text{ lb.} \leftarrow \text{Controls}$$

$$\text{Pryout capacity} = 6,838 \text{ lb.}$$

$\therefore \phi V_n = 2,224 \text{ lb. as concrete breakout capacity controls}$

11. Check interaction of tension and shear forces:

If $0.2 \phi V_n \geq V_{ua}$, then the full tension design strength is permitted.

By observation, this is not the case.

If $0.2 \phi N_n \geq N_{ua}$, then the full shear design strength is permitted

By observation, this is not the case.

Therefore:

$$\frac{N_{ua}}{\phi N_n} + \frac{V_{ua}}{\phi V_n} \leq 1.2$$

$$\frac{1,600}{2,659} + \frac{560}{2,224} = 0.60 + 0.25 = 0.85 < 1.2 \text{ O.K.}$$

12. Summary

A single 1/2" diameter carbon-steel Strong-Bolt® 2 anchor at a 3 7/8" embedment depth is adequate to resist the applied strength level tension and shear wind loads of 1,600 lb. and 560 lb., respectively.

Example Calculations Adhesive Anchors (ACI 318 App.D / ICC-ES AC308)

Example calculation for a single SET-XP® epoxy adhesive anchor using SD:

Determine if a single 1/2" diameter ASTM A193 Grade B7 anchor rod in SET-XP® epoxy adhesive anchor with a minimum 4 1/2" embedment ($h_{ef} = 4\frac{1}{2}"$) installed 1 3/4" from the edge of a 12" deep spandrel beam is adequate for a strength level tension load of 1,040 lb. for wind and a reversible strength level shear load of 440 lb. for wind. The anchor will be in the tension zone, away from other anchors in $f'_c = 3,000$ psi normal-weight concrete (dry). The anchor will be subjected to a maximum short-term temperature of 150°F and a maximum long-term temperature of 110°F. Continuous inspection will be provided

Reference the appropriate tables in this catalog for SET-XP epoxy adhesive anchor performance values as determined from testing in accordance with ACI 355.4 and ICC-ES AC308.

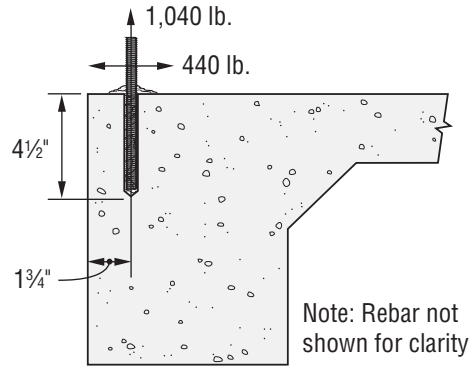

CALCULATIONS AND DISCUSSION

REFERENCE

Note: Calculations are performed in accordance with ICC-ES AC308 and ACI 318-11.

1. Determine the factored tension and shear design loads:

ACI 318, 9.2.1

$$N_{ua} = 1.0W = 1.0 \times 1,040 = 1,040 \text{ lb.}$$

$$V_{ua} = 1.0W = 1.0 \times 440 = 440 \text{ lb.}$$

2. Design considerations:

D.4.1.1

This is a combined tension and shear interaction problem where values for both ϕN_n and ϕV_n need to be determined. ϕN_n is the lesser of the design tension strength controlled by: steel (ϕN_{sa}), concrete breakout (ϕN_{cb}), or adhesive (ϕN_a). ϕV_n is the lesser of the design shear strength controlled by: steel (ϕV_{sa}), concrete breakout (ϕV_{cb}), or pryout (ϕV_{cp}).

3. Steel capacity under tension loading:

D.5.1

$$\phi N_{sa} \geq N_{ua}$$

D.4.1.1

$$N_{sa} = 17,750 \text{ lb.}$$

This catalog

$$\phi = 0.75$$

This catalog

$$n = 1 \text{ (single anchor)}$$

Calculating for ϕN_{sa} :

$$\phi N_{sa} = 0.75 \times 1 \times 17,750 = 13,313 \text{ lb.} > 1,040 \text{ lb. O.K.}$$

CALCULATIONS AND DISCUSSION

REFERENCE

4. Concrete breakout capacity under tension loading:

D.5.2

$$\phi N_{cb} \geq N_{ua}$$

D.4.1.1

$$N_{cb} = \frac{A_{Nc}}{A_{Nco}} \psi_{ed,N} \psi_{c,N} \psi_{cp,N} N_b$$

Eq. (D-3)

where:

$$N_b = k_c \lambda_a \sqrt{f'_c} h_{ef}^{1.5}$$

Eq. (D-6)

substituting:

$$\phi N_{cb} = \phi \frac{A_{Nc}}{A_{Nco}} \psi_{ed,N} \psi_{c,N} \psi_{cp,N} k_c \lambda_a \sqrt{f'_c} h_{ef}^{1.5}$$

where:

$$k_c = k_{cr} = 17$$

This catalog

$$\lambda_a = 1.0 \text{ for normal-weight concrete}$$

8.6.1

$$\psi_{cp,N} = 1.0$$

D.5.2.7

$$\psi_{ed,N} = 0.7 + 0.3 \frac{C_{a,min}}{1.5h_{ef}} \text{ when } C_{a,min} < 1.5h_{ef}$$

Eq. (D-10)

by observation, $C_{a,min} < 1.5h_{ef}$

$$\psi_{ed,N} = 0.7 + 0.3 \frac{1.75}{1.5(4.5)} = 0.78$$

$$\psi_{c,N} = 1.0$$

D.5.2.6

$\phi = 0.65$ for Condition B
(no supplementary reinforcement provided)

This catalog

$$A_{Nco} = 9h_{ef}^2 = 9(4.5)^2 = 182.25 \text{ in.}^2$$

Eq. (D-5)

$$A_{Nc} = (c_{a1} + 1.5h_{ef})(2 \times 1.5h_{ef}) = (1.75 + 1.5(4.5))(2 \times 1.5(4.5)) = 114.75 \text{ in.}^2$$

Fig. RD.5.2.1(a)

$$\frac{A_{Nc}}{A_{Nco}} = \frac{114.75}{182.25} = 0.63$$

$$f'_c = 2,500 \text{ psi}$$

ICC-ES ESR-2508 section 5.3

Calculating for ϕN_{cb} :

$$\phi N_{cb} = 0.65 \times 0.63 \times 1.0 \times 0.78 \times 1.0 \times 17 \times 1.0 \times \sqrt{2,500} \times (4.5)^{1.5} = 2,592 \text{ lb.} > 1,040 \text{ lb. O.K.}$$

Continued on next page

Would you like help with these calculations?
Visit www.strongtie.com to download the Simpson Strong-Tie® Anchor Designer™ software.

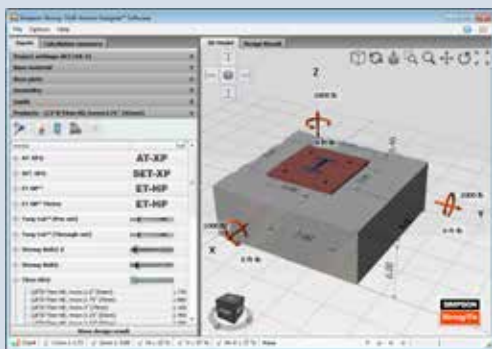

Example Calculations Adhesive Anchors (ACI 318 App.D / ICC-ES AC308)

CALCULATIONS AND DISCUSSION

5. Adhesive anchor capacity under tension loading:

$$\phi N_a \geq N_{ua}$$

$$N_a = \frac{A_{Na}}{A_{Na0}} \psi_{ed,Na} \psi_{cp,Na} N_{ba}$$

$$N_{ba} = \tau_{k,cr} \pi d_a h_{ef} = 510(1.72)\pi(0.5)(4.5) = 6,200 \text{ lb.} \quad \text{Eq. (D-22)}$$

$$c_{Na} = 10d_a \sqrt{\frac{\tau_{k,uncr}}{1,100}} \quad \text{Eq. (D-21)}$$

$$c_{Na} = (10)(0.5) \sqrt{\frac{1,150(1.72)}{1,100}} = 6.70''$$

$$A_{Na0} = (2c_{Na})^2 = (13.40)^2 = 179.56 \text{ in.}^2 \quad \text{Eq. (D-20)}$$

$$A_{Na} = (c_{a1} + 2c_{Na})(2c_{Na}) = (1.75 + 6.70)(13.40) = 113.23 \text{ in.}^2$$

$$\psi_{ed,Na} = \left(0.7 + 0.3 \frac{c_{a,min}}{c_{Na}}\right) \leq 1.0 \quad \text{Since } c_{a,min} < c_{Na} \quad \text{Eq. (D-25)}$$

$$\psi_{ed,Na} = \left(0.7 + 0.3 \frac{c_{a,min}}{c_{Na}}\right) = \left(0.7 + 0.3 \frac{1.75}{6.70}\right) = 0.78$$

$$\psi_{cp,Na} = 1.0 \quad \text{D.5.5.5}$$

$$\phi = 0.65 \text{ for dry concrete} \quad \text{This catalog}$$

Calculating for ϕN_a :

$$\phi N_a = 0.65 \times \frac{113.23}{179.56} \times 0.78 \times 1.0 \times 6,200 = 1,982 \text{ lb.} > 1,040 \text{ lb. O.K.}$$

6. Check all failure modes under tension loading: D.4.1.1

Summary:

Steel capacity = 13,313 lb.

Concrete breakout capacity = 2,592 lb.

Adhesive capacity = 1,982 lb. ← **Controls**

∴ $\phi N_n = 1,982 \text{ lbs. as adhesive capacity controls}$

7. Steel capacity under shear loading: D.6.1

$$\phi V_{sa} \geq V_{ua}$$

$$V_{sa} = 10,650 \text{ lb.} \quad \text{This catalog}$$

$$\phi = 0.65 \quad \text{This catalog}$$

Calculating for ϕV_{sa} :

$$\phi V_{sa} = 0.65 \times 10,650 = 6,923 \text{ lb.} > 440 \text{ lb. O.K.}$$

REFERENCE

D.5.5

D.4.1.1

Eq. (D-18)

Eq. (D-22)

Eq. (D-21)

Eq. (D-20)

Eq. (D-25)

D.5.5.5

This catalog

D.4.1.1

D.6.1

D.4.1.1

This catalog

This catalog

CALCULATIONS AND DISCUSSION

8. Concrete breakout capacity under shear loading:

$$\phi V_{cb} \geq V_{ua}$$

$$V_{cb} = \frac{A_{Vc}}{A_{Vco}} \psi_{ed,V} \psi_{c,V} \psi_{h,V} V_b$$

where:

$$V_b = 7 \left(\frac{\ell_e}{d_a}\right)^{0.2} \sqrt{d_a} \lambda_a \sqrt{f'_c} c_{a1}^{1.5} \quad \text{Eq. (D-33)}$$

substituting:

$$\phi V_{cb} = \phi \frac{A_{Vc}}{A_{Vco}} \psi_{ed,V} \psi_{c,V} \psi_{h,V} 7 \left(\frac{\ell_e}{d_a}\right)^{0.2} \sqrt{d_a} \lambda_a \sqrt{f'_c} c_{a1}^{1.5}$$

where:

$\phi = 0.70$ for Condition B

(no supplementary reinforcement provided) D.4.4(c)(i)

$$A_{Vco} = 4.5c_{a1}^2 = 4.5(1.75)^2 \quad \text{Eq. (D-32)}$$

$$\therefore A_{Vco} = 13.78 \text{ in.}^2$$

$$A_{Vc} = 2(1.5c_{a1})(1.5c_{a1}) = 2(1.5(1.75))(1.5(1.75)) \quad \text{Fig. RD.6.2.1(a)}$$

$$= 2(1.5(1.75))(1.5(1.75))$$

$$\therefore A_{Vc} = 13.78 \text{ in.}^2$$

$$\therefore A_{Vc} = 13.78 \text{ in.}^2$$

$$\frac{A_{Vc}}{A_{Vco}} = \frac{13.78}{13.78} = 1$$

$$\frac{A_{Vc}}{A_{Vco}} = \frac{13.78}{13.78} = 1 \quad \text{D.6.2.1}$$

$$h_a = 12 \text{ in.}$$

$$\psi_{h,V} = 1.0 \text{ since } h_a > 1.5c_{a1} \quad \text{D.6.2.8}$$

$$\psi_{ed,V} = 1.0 \text{ since } c_{a2} > 1.5c_{a1} \quad \text{Eq. (D-37)}$$

$$\psi_{c,V} = 1.0 \text{ for cracked concrete} \quad \text{D.6.2.7}$$

$$d_a = 0.5 \text{ in.}$$

$$\ell_e = 8d_a = 8(0.5) = 4'' \quad \text{D.6.2.2}$$

$$\lambda = 1.0 \text{ for normal-weight concrete} \quad \text{8.6.1}$$

$$c_{a1} = 1.75 \text{ in.}$$

$$\phi V_{cb} = 0.70 \times 1 \times 1.0 \times 1.0 \times 1.0 \times 7 \times \left(\frac{4}{0.5}\right)^{0.2} \times \sqrt{0.5} \times 1.0$$

$$\times \sqrt{3,000} \times (1.75)1.5 = 666 \text{ lb.} > 440 \text{ lb. O.K.}$$

9. Concrete pryout capacity under shear loading: D.6.3

$$V_{cp} = \min[k_{cp} N_a; k_{cp} N_{cb}] \quad \text{D.6.3.1}$$

$$k_{cp} = 2.0 \text{ for } h_{ef} \geq 2.5''$$

$$N_a = 3,050 \text{ lb. from adhesive-capacity calculation without } \phi \text{ factor}$$

$$N_{cb} = 3,988 \text{ lb. from concrete-breakout calculation without } \phi \text{ factor}$$

$$V_{cp} = (2.0)(3,050) = 6,100 \text{ lb. controls}$$

$$\phi = 0.7$$

This catalog

$$\phi V_{cp} = (0.7)(6,100) = 4,270 \text{ lb.} > 440 \text{ lb. O.K.}$$

Continued on next page

Example Calculations Adhesive Anchors (ACI 318 App.D / ICC-ES AC308)

CALCULATIONS AND DISCUSSION

REFERENCE

10. Check all failure modes under shear loading:

D.4.1.1

Summary:

Steel capacity = 6,923 lb.

Concrete breakout capacity = 666 lb. ← **Controls**

Pryout capacity = 4,270 lb.

∴ $\phi V_n = 666$ lb. as concrete breakout capacity controls

11. Check interaction of tension and shear forces:

D.7

If

$$\frac{V_{ua}}{\phi V_n} \leq 0.2$$

then the full tension design strength is permitted.

D.7.1

By observation, this is not the case.

If

$$\frac{N_{ua}}{\phi N_n} \leq 0.2$$

then the full shear design strength is permitted.

D.7.2

By observation, this is not the case.

Therefore:

$$\frac{N_{ua}}{\phi N_n} + \frac{V_{ua}}{\phi V_n} \leq 1.2$$

Eq. (D-42)

$$\frac{1,040}{1,982} + \frac{440}{666} = 0.52 + 0.66 = 1.18 < 1.2 \text{ O.K.}$$

12. Summary

A single ½" diameter ASTM A193 Grade B7 anchor rod in SET-XP® epoxy adhesive at a 4½" embedment depth is adequate to resist the applied strength level tension and shear wind loads of 1,040 lb. and 440 lb., respectively.

Suggested General Notes for Anchor Products

To download the full text of Suggested General Notes, please visit strongtie.com/products/anchorsystems/technicalinfo/suggested-specs.html.

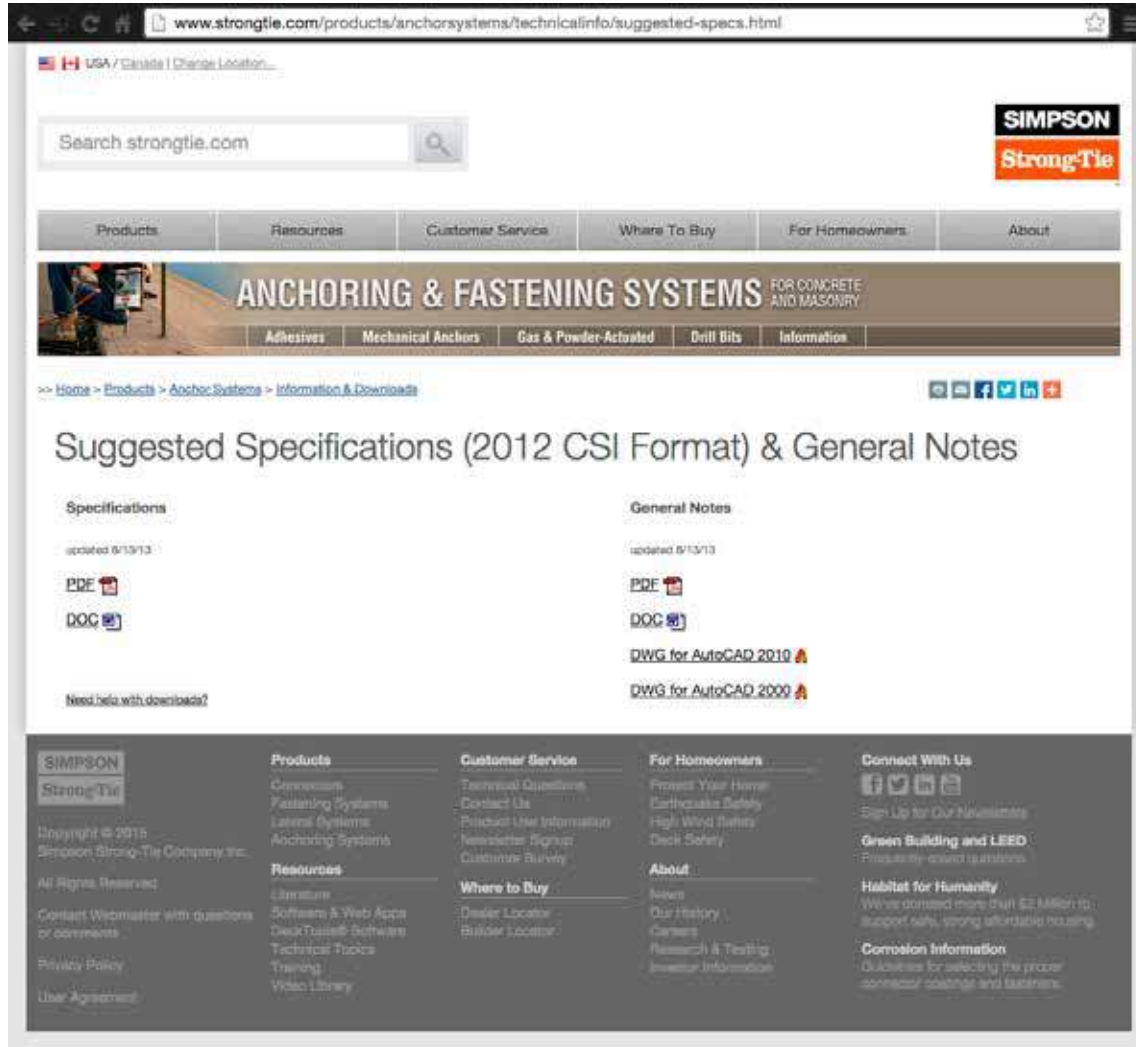

Glossary

ACI — American Concrete Institute

ACRYLIC — Polymer based on resins prepared from a combination of acrylic and methacrylic esters.

ADHESIVE ANCHOR — Typically, a threaded rod or rebar that is installed in a predrilled hole in a base material with a two-part chemical compound.

ADMIXTURE — A material other than water, aggregate or hydraulic cement used as an ingredient of concrete and added to concrete before or during its mixing to modify its properties.

AERATED CONCRETE — Concrete that has been mixed with air-entraining additives to protect against freeze-thaw damage and provide additional workability.

AGGREGATE — A granular material, such as sand, gravel, crushed stone and iron blast-furnace slag, used with a cementing medium to form a hydraulic cement concrete or mortar.

AISC — American Institute of Steel Construction

ALLOWABLE LOAD — The maximum design load that can be applied to an anchor. Allowable loads for mechanical and adhesive anchors are based on applying a factor of safety to the average ultimate load.

ALLOWABLE STRESS DESIGN (ASD) — A design method in which an anchor is selected such that service loads do not exceed the anchor's allowable load. The allowable load is the average ultimate load divided by a factor of safety.

AMINE CURING AGENT — Reactive ingredient used as a setting agent for epoxy resins to form highly crosslinked polymers.

ANCHOR CATEGORY — The classification for an anchor that is established by the performance of the anchor in reliability tests such as sensitivity to reduced installation effort for mechanical anchors or sensitivity to hole cleaning for adhesive anchors.

ANSI — American National Standards Institute

ASTM — American Society for Testing and Materials

BASE MATERIAL — The substrate (concrete, CMU, etc.) into which adhesive or mechanical anchors are to be installed.

BOND STRENGTH — The mechanical interlock or chemical bonding capacity of an adhesive to both the insert and the base material.

BRICK — A solid masonry unit of clay or shale formed into a rectangular prism while plastic and burned or fired in a kiln that may have cores or cells comprising less than 25% of the cross sectional area.

CAMA — Concrete Anchor Manufacturer's Association

CAST-IN-PLACE ANCHOR — A headed bolt, stud or hooked bolt installed into formwork prior to placing concrete.

CHARACTERISTIC DESIGN VALUE — The nominal strength for which there is 90% confidence that there is a 95% probability of the actual strength exceeding the nominal strength.

CONCRETE — A mixture of Portland cement or any other hydraulic cement, fine aggregate, coarse aggregate and water, with or without admixtures. Approximate weight is 150 pcf.

CONCRETE BRICK — A solid concrete masonry unit (CMU) made from Portland cement, water, and aggregates.

CONCRETE COMPRESSIVE STRENGTH (f'_c) — The specified compressive load carrying capacity of concrete used in design, expressed in pounds per square inch (psi) or megapascals (MPa).

CONCRETE MASONRY UNIT (CMU) — A hollow or solid masonry unit made from cementitious materials, water and aggregates.

CORE DRILL — A method of drilling a smooth wall hole in a base material using a special drill attachment.

CREEP — Displacement under a sustained load over time.

CURE TIME — The elapsed time required for an adhesive anchor to develop its ultimate carrying capacity.

DESIGN LOAD — The calculated maximum load that is to be applied to the anchor for the life of the structure.

DESIGN STRENGTH — The nominal strength of an anchor calculated per ACI 318, ICC-ES AC193 or ICC-ES AC308 and then multiplied by a strength reduction factor (ϕ).

DROP-IN ANCHOR — A post-installed mechanical anchor consisting of an internally-threaded steel shell and a tapered expander plug. The bottom end of the steel shell is slotted longitudinally into equal segments. The anchor is installed in a pre-drilled hole using a hammer and a hand-setting tool. The anchor is set when the tapered expander plug is driven toward the bottom end of the anchor such that the shoulder of the hand-setting tool makes contact with the top end of the anchor. A drop-in anchor may also be referred to as a displacement controlled expansion anchor.

DYNAMIC LOAD — A load whose magnitude varies with time.

EDGE DISTANCE:

EDGE DISTANCE (C) — The measure between the anchor centerline and the free edge of the concrete or masonry member.

CRITICAL EDGE DISTANCE (C_{cr} or C_{ac}) — The least edge distance at which the allowable load capacity of an anchor is applicable without reductions.

MINIMUM EDGE DISTANCE (C_{min}) — The least edge distance at which the anchors are tested for recognition.

EFFECTIVE EMBEDMENT DEPTH — The dimension measured from the concrete surface to the deepest point at which the anchor tension load is transferred to the concrete.

EMBEDMENT DEPTH — The distance from the top surface of the base material to the installed end of the anchor. In the case of a post-installed mechanical anchor, the embedment depth is measured prior to application of the installation torque.

EPOXY RESIN — A viscous liquid containing epoxide groups that can be crosslinked into final form by means of a chemical reaction with a variety of setting agents.

EXPANSION ANCHOR — A mechanical fastener placed in hardened concrete or assembled masonry, designed to expand in a self-drilled or predrilled hole of a specified size and engage the sides of the hole in one or more locations to develop shear and/or tension resistance to applied loads without grout, adhesive or drypack.

FATIGUE LOAD TEST — A test in which the anchor is subjected to a specified load magnitude for 2×10^6 cycles in order to establish the endurance limit of the anchor.

Glossary

GEL TIME — The elapsed time at which an adhesive begins to increase in viscosity and becomes resistant to flow.

GROUT — A mixture of cementitious material and aggregate to which sufficient water is added to produce pouring consistency without segregation of the constituents.

GROUTED MASONRY (or GROUT-FILLED MASONRY) — Hollow-unit masonry in which the cells are filled solidly with grout. Also, double or triple-wythe wall construction in which the cavity(s) or collar joint(s) is filled solidly with grout.

HOT-DIP GALVANIZED — A part coated with a relatively thick layer of zinc by means of dipping the part in molten zinc.

IAPMO UES — IAPMO Uniform Evaluation Service. An ISO 17065 ANSI-accredited company that issues evaluation reports expressing a professional opinion as to a product's building code compliance.

IBC — International Building Code.

ICC-ES — ICC Evaluation Service. An ISO 17065 ANSI-accredited company that issues evaluation reports expressing a professional opinion as to a product's building code compliance.

LEGACY ACCEPTANCE CRITERIA — A past version of an ICC-ES anchor qualification criteria. These are no longer current standards, but are the basis for legacy allowable load data for anchors in concrete. These standards have been replaced by modern standards such as ICC-ES AC193 and AC308.

LIGHTWEIGHT CONCRETE — Concrete containing lightweight aggregate. The unit weight of lightweight concrete is not to exceed 115 pcf.

MASONRY — Brick, structural clay tile, stone, concrete masonry units or a combination thereof bonded together with mortar.

MECHANICALLY GALVANIZED — A part coated with a layer of zinc by means of mechanical impact. The thickest levels of mechanical galvanizing (ASTM B695, Class 55 or greater) are considered to be alternatives to hot-dip galvanizing and provide a medium level of corrosion resistance.

MORTAR — A mixture of cementitious materials, fine aggregate and water used to bond masonry units together.

NOMINAL STRENGTH — The strength of an element as calculated per ACI 318, ICC-ES AC193 or ICC-ES AC308.

NORMAL WEIGHT CONCRETE — Concrete containing normal weight aggregate. The unit weight of normal weight concrete is approximately 150 pcf.

OBLIQUE LOAD — A load that is applied to an anchor, which can be resolved into tension and shear components.

PLAIN CONCRETE — Structural concrete with no reinforcement or with less reinforcement than the minimum specified for reinforced concrete.

PORTLAND CEMENT — Hydraulic cement consisting of finely pulverized compounds of silica, lime and alumina.

POST-INSTALLED ANCHOR — Either a mechanical or adhesive anchor installed in a pre-drilled hole in the base material.

POST-TENSION — A method of prestressing in which tendons are tensioned after concrete has hardened.

POT LIFE — The length of time a mixed adhesive remains workable (flowable) before hardening.

PRECAST CONCRETE — A concrete structural element cast elsewhere than its final position in the structure.

PRESTRESSED CONCRETE — Structural concrete in which internal stresses have been introduced to reduce potential tensile stresses in concrete resulting from loads.

PRETENSIONING — A method of prestressing in which tendons are tensioned before concrete is placed.

REBAR — Deformed reinforcing steel which comply with ASTM A615.

REINFORCED CONCRETE — Structural concrete reinforced with no less than the minimum amount of prestressed tendons or nonprestressed reinforcement specified in ACI 318.

REINFORCED MASONRY — Masonry units and reinforcing steel bonded with mortar and/or grout in such a manner that the components act together in resisting forces.

REQUIRED STRENGTH — The factored loads and factored load combinations that must be resisted by an anchor.

SCREEN TUBE — Typically a wire or plastic mesh tube used with adhesives for anchoring into hollow base materials to prevent the adhesive from flowing uncontrolled into voids.

SCREW ANCHOR — A post-installed anchor that is a threaded mechanical fastener placed in a predrilled hole. The anchor derives its tensile holding strength from the mechanical interlock of the fastener threads with the grooves cut into the concrete during the anchor installation.

SHEAR LOAD — A load applied perpendicular to the axis of an anchor.

SHOTCRETE — Concrete that is pneumatically projected onto a surface at high velocity. Also known as gunite.

SLEEVE ANCHOR — A post-installed mechanical anchor consisting of a steel stud with nut and washer, threaded on the top end and a formed uniform tapered mandrel on the opposite end around which a full length expansion sleeve formed from sheet steel is positioned. The anchor is installed in a predrilled hole and set by tightening the nut by torquing thereby causing the expansion sleeve to expand over the tapered mandrel to engage the base material.

SPACING:

SPACING (S) — The measure between anchors, centerline-to-centerline distance.

CRITICAL SPACING (S_{cr}) — The least anchor spacing distance at which the allowable load capacity of an anchor is applicable such that the anchor is not influenced by neighboring anchors.

MINIMUM SPACING (S_{min}) — The least anchor spacing at which the anchors are tested for recognition.

STAINLESS STEEL — A family of iron alloys containing a minimum of 12% chromium. Type-316 stainless steel provides greater corrosion resistance than Types 303 or 304.

STANDARD DEVIATION — As it pertains to this catalog, a statistical measure of how widely dispersed the individual test results were from the published average ultimate loads.

Glossary

STATIC LOAD — A load whose magnitude does not vary appreciably over time.

STRENGTH DESIGN (SD) — A design method in which an anchor is selected such that the anchor's design strength is equal to or greater than the anchor's required strength.

STRENGTH REDUCTION FACTOR (ϕ) — A factor applied to the nominal strength to allow for variations in material strengths and dimensions, inaccuracies in design equations, required ductility and reliability, and the importance of the anchor in the structure.

TENDON — In pretensioned applications, the tendon is the prestressing steel. In post-tensioned applications, the tendon is a complete assembly consisting of anchorages, prestressing steel, and sheathing with coating for unbonded applications or ducts with grout for bonded applications.

TENSION LOAD — A load applied parallel to the axis of an anchor.

THIXOTROPIC — The ability of a fluid to become less viscous (resistant to flow) under shear, then thicken when the shear force is removed.

TORQUE — The measure of the force applied to produce rotational motion usually measured in foot-pounds. Torque is determined by multiplying the applied force by the distance from the pivot point to the point where the force is applied.

ULTIMATE LOAD — The average value of the maximum loads that were achieved when five or more samples of a given product were installed and statically load tested to failure under similar conditions. The ultimate load is used to derive the allowable load by applying a factor of safety.

UNDERCUT ANCHOR — A post-installed anchor that develops its tensile strength from the mechanical interlock provided by undercutting of the concrete at the embedded end of the anchor.

UNREINFORCED MASONRY (URM) — A form of clay brick masonry bearing wall construction consisting of multiple wythes periodically interconnected with header courses. In addition, this type of wall construction contains less than the minimum amounts of reinforcement as defined for reinforced masonry walls.

WEDGE ANCHOR — A post-installed mechanical anchor consisting of a steel stud with nut and washer, threaded on the top end and a formed uniform tapered mandrel on the opposite end around which an expansion clip formed from sheet steel is positioned. The anchor is installed in a predrilled hole and set by tightening the nut by torquing, thereby causing the expansion clip to expand over the tapered mandrel to engage the base material. A wedge anchor may also be referred to as a torque controlled expansion anchor.

WYTHE — A continuous vertical section of masonry one unit in thickness.

ZINC PLATED — A part coated with a relatively thin layer of zinc by means of electroplating.

Alphabetical Index of Products

AD	Drill Bit Shank Adaptor	309
ADT	Acrylic Dispensing Tools	128
ADTA	Acrylic Battery-Powered and Pneumatic Dispensing Tools	128
AMN	Acrylic Mixing Nozzle	129
ARC	Adhesive Retaining Caps	132
AST	Adhesive Shear Tube	135
AT	Acrylic Adhesive	86–101
AT-XP	Acrylic Adhesive	20–37
ATS & ATSP	Acrylic Screens	133–134
BBMD	Blue Banger Hanger®	215
BBRD	Blue Banger Hanger®	216
BBWF	Blue Banger Hanger®	214
CBMX	One-Piece Core Bit – SDS-MAX Shank	313
CBSP	One-Piece Core Bit – Spline Shank	313
CD	Crimp Drive® Anchor	242–243
CDBE	One-Piece Core Bit – Ejector Key	313
CDT10S	Adhesive Dispensing Tool	128, 287
CHH	Hex Shank Chisels and Demolition Bits	311–312
CHMX	SDS-MAX Chisels and Demolition Bits	310–312
CHPL	SDS-PLUS Chisels and Demolition Bits	310–311
CHSP	Spline Shank Chisels and Demolition Bits	311
CIP-F	Crack Injection Paste Over	288–289, 293
CPFH	Crack-Pac® Flex-H20™ Crack Sealer	288
CSD	Countersunk Split Drive	244
CTRB	One-Piece Core Bit – Center Pilot Bit	313
DIA	Drop-In Anchor	229–235
DIAB	Drop-In Anchor	224–228
DIABST	Drop-In Anchor Setting Tool	225
DIAST	Drop-In Anchor Setting Tool	230
DSD	Duplex Head Split Drive	244
EDOT	General-Purpose Epoxy Anchoring Adhesive	122–123
EDT	Epoxy Dispensing Tools	128
EDTA	Epoxy Battery-Powered and Pneumatic Dispensing Tools	128
EIF	Injection Fitting	289
EIP	Injection Port	288–289
EMN	Epoxy Mixing Nozzle	129
ESA	Expansion Screw Anchor	240
ET-HP®	Epoxy Adhesive	62–85
ETB	Hole-Cleaning Brush	135
ETI	Crack Injection Epoxy	284–285
ETIPAC	Crack-Pac® Injection Epoxy	286
ETR	Epoxy Paste	286, 288–289
ETS & ETSP	Epoxy Screens	133–134
EZAC	Easy-Set Pin-Drive Anchor	179
E-Z-Click	Injection System	286, 288–289
GAC	Gas Pins	251
GCC	Gas Pins	251

Alphabetical Index of Products

GCL	Gas Pins	251
GCN-MEP	Gas-Actuated Concrete Nailer	248
GCT	Gas Pins	251
GDP	Gas Pins	249
GDPS	Gas Pins	249
GDPSK	Spiral-Knurled Gas Pins	250
GFC	Gas Fuel Cell	250
GMR-2	Magnetic Ring	250
GRH	Gas Pins	251
GTH	Gas Pins	251
GTS	Gas Pins	251
GW	Gas Pins	251
GWL-100	Lathing Washer	250
HDIA	Hollow Drop-In Anchor	236–238
HELI	Heli-Tie Helical Wall and Stitching Tie	290–292
LSES	Lag Screw Expansion Shield	239
MC	Rebar Cutter Shank – Straight	308
MCP	Plate Cutter Head	308
MCR	Rebar Cutter Head	308
MCS	Rebar Cutter Shank – Spline	308
MCSDM	Rebar Cutter Shank – SDS-MAX	308
MCSDP	Rebar Cutter Shank – SDS-PLUS	308
MDA	“A” Taper Shank Drill Bits	306
MDB	Straight Shank Drill Bits	207, 307
MDBP	Titen Drill Bit / Driver	207, 303
MDMX	SDS-MAX & SDS-MAX Quad Head Bits	304
MDPL	SDS-PLUS Shank Bits	225, 230, 302
MDSP	Spline Shank Drill Bits	305–306
P22	.22 Cal. Powder Load – Single, Crimped	253, 265
P22LRSC	.22 Cal. Powder Load – Single, Straight Wall	253, 265
P25SL	.25 Cal. Powder Load – Strip	253, 265
P27LVL	.27 Cal. Powder Load – Single, Long	253, 265
P27SL	.27 Cal. Powder Load – Strip	253, 265
PBXDP	BX Cable Strap	253, 269
PCC	Conduit Clip	253, 269
PCLDPA	Ceiling Clip	253, 267
PDPA	0.157” Shank Diameter Drive Pin	253, 266
PDPAS	.157” Shank Diameter Drive Pin	253, 267
PDPAT	0.157” Shank Diameter Tophat Fastener	253, 267
PDPAW	0.157” Shank Diameter with ¾” Metal Washer	253, 266
PDPAWL	0.157” Shank Diameter with 1” Metal Washer	253, 266
PDPWLSS	0.145” Shank Diameter and 1” Metal Washer – Type-304 Stainless Steel	253, 268
PECLDPA	Ceiling Clip	253, 267
PEPT	Pole Tool / Accessories	252
PEPT-LR	Pole Tool / Accessories	252, 257, 259
PHBC	Highway Basket Clip	253, 269
PHD	Hammer Drive Pin	272

Alphabetical Index of Products

PHN	8mm Head Pin	253, 270
PHNT	8mm Tophat Fastener	253, 271
PHNW	8mm Headed Pin with 1" Washer	253, 271
PHT	Hammer Drive Tool	272
PINW	100 through 300 – 0.300" Headed Pin with 1 7/16" Washer	253, 268
PINWP	100 through 300 – 0.300" Headed Pin with 1 7/16" Plastic Washer	253, 268
PKP	Concrete Forming Pin	253, 272
PSLV3	3/8" Threaded Stud	253, 270
PSLV4	1/4" Threaded Stud	253, 269
PT-22A	.22 Cal. Powder-Actuated Tool	253, 255, 262
PT-22HA	Hammer-Activated Powder Tool	253, 255, 263
PT-22P	Powder-Actuated Tool	253, 255, 264
PT-27	.27 Cal. Powder-Actuated Tool	252, 253, 255, 261
PT-27HDA	Heavy-Duty Powder-Actuated Tool	253, 255, 260
PTP-27L	.27 Cal. Auto Powder-Actuated Tool	252–254, 256–257
PTP-27LMAGR	.27 Cal. Auto Powder-Actuated Tool with Magazine	252–254, 256–257
PTP-27S	.27 Cal. Auto Powder-Actuated Tool	252–254, 258–259
PTP-27SMAGR	.27 Cal. Auto Powder-Actuated Tool with Rotating Magazine	252–254, 258–259
PTRHA	0.157" Shank Diameter Threaded Rod Hanger	253, 267
RFB	Retrofit Bolt	135
RWH	Horizontal Wood Rod Hanger	212–213
RWV	Vertical Wood Rod Hanger	212–213
SET	Epoxy Adhesive	102–121
SET-XP®	Epoxy Adhesive	38–61
SL	Sleeve-All® Anchor	180–183
STB2	Strong-Bolt® 2 Wedge Anchor	144–163
SWN	Sure Wall Anchor – Nylon	245
SWZ	Sure Wall Anchor – Zinc	245
TCA	Torq-Cut™ Anchor	138–143
THD	Titen HD® Heavy-Duty Screw Anchor	184–199
THDB	Titen HD® Heavy-Duty Screw Anchor	184–199
THD RC	Titen HD® Rod Coupler	201–202
THD RH	Titen HD® Rod Hanger	208–211
TTN	Titen® Concrete and Masonry Screw	203–204
TTNSS	Titen® Concrete and Masonry Screw – Stainless Steel	205–206
TTNT	Titen® Screw Installation Tool	207
TW	Tie Wire Anchor	177–178
WA	Wedge-All® Anchor	164–176
ZN	Zinc Nailon™	241

Notes

A large grid of graph paper for taking notes, consisting of 20 columns and 30 rows of small squares.

Notes

A large grid of graph paper for taking notes, consisting of 20 columns and 30 rows of small squares.

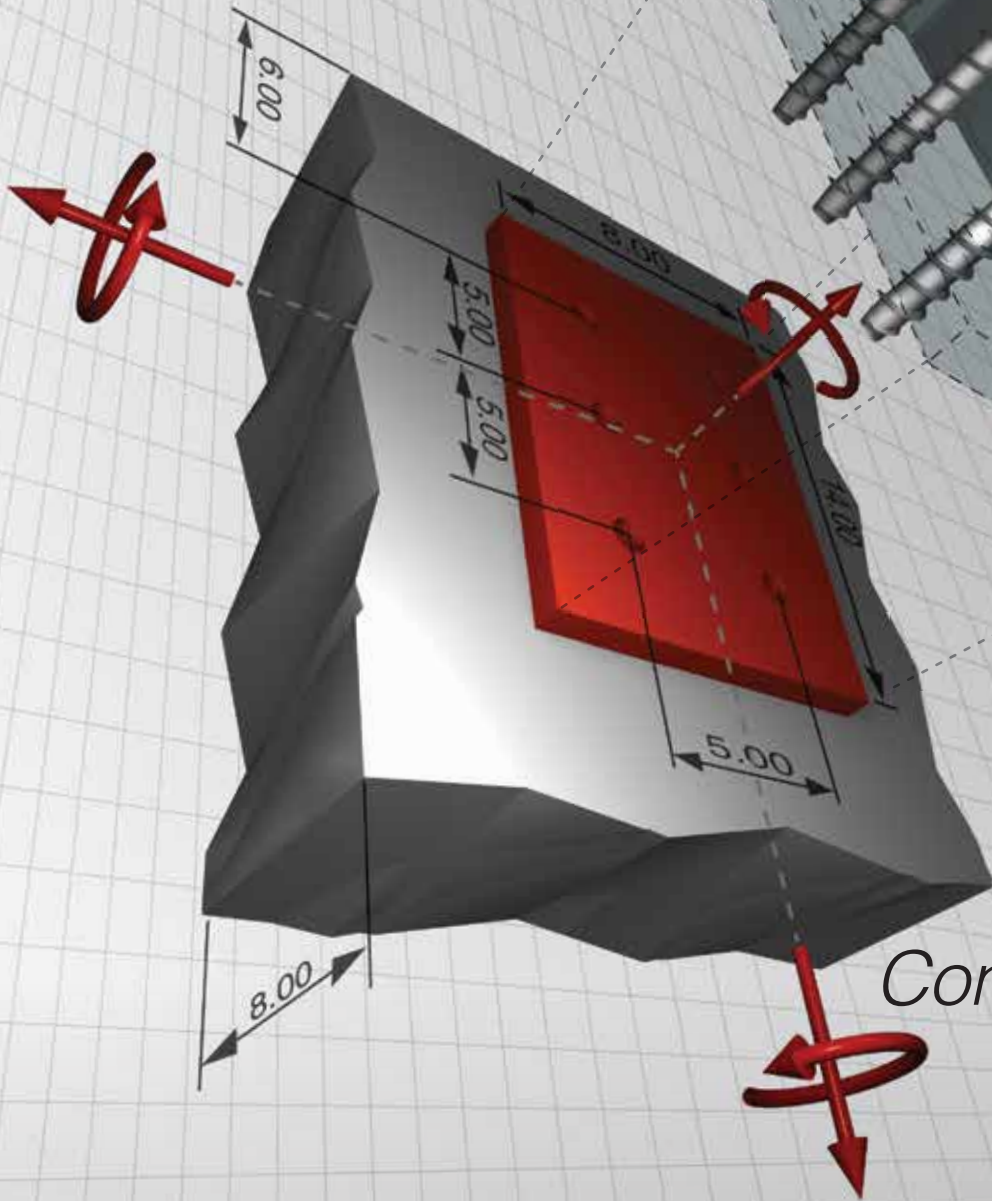

Powerful calculations, *Concrete solutions*



Performing challenging calculations required by current design methodologies can be completed quickly and accurately with the new Simpson Strong-Tie® Anchor Designer™ software. A fully interactive 3D graphical-user interface with 42 pre-loaded anchor configurations simplify input, and calculation results are output for verification and submission of your design. Anchor Designer complies with current ACI 318, ETAG and CSA code requirements.

Call (800) 999-5099 to learn more and download the free software at strongtie.com/anchordesigner.

SIMPSON
Strong-Tie